

ENGINE FUEL & EMISSION CONTROL SYSTEM

SECTION **EF & EC**

EF & EC

CONTENTS

PRECAUTIONS	EF & EC- 2
COMPONENT PARTS LOCATION	EF & EC- 3
E C C.S DIAGRAM	EF & EC- 4
E C C S CHART	EF & EC- 6
E C C.S WIRING DIAGRAM	EF & EC- 8
FUEL FLOW SYSTEM DESCRIPTION	EF & EC-10
AIR FLOW SYSTEM DESCRIPTION	EF & EC-11
E C C.S. DESCRIPTION	EF & EC-13
DIAGNOSTIC PROCEDURE	EF & EC-28
SELF-DIAGNOSIS	EF & EC-35
ELECTRONIC CONTROL SYSTEM INSPECTION	EF & EC-43
MIXTURE RATIO FEEDBACK SYSTEM INSPECTION	EF & EC-60
FUEL SYSTEM INSPECTION	EF & EC-63
TURBOCHARGER	EF & EC-66
INJECTOR COOLING FAN (VG30ET)	EF & EC-69
PRESSURE REGULATOR CONTROL	EF & EC-72
CRANKCASE EMISSION CONTROL SYSTEM	EF & EC-74
EXHAUST EMISSION CONTROL SYSTEM	EF & EC-75
EVAPORATIVE EMISSION CONTROL SYSTEM	EF & EC-76
SERVICE DATA AND SPECIFICATIONS (S.D.S)	EF & EC-79

PRECAUTIONS

- Always use 12 volt batteries as power source
- Do not attempt to disconnect battery cables while engine is operating

- Do not disassemble E C C S control unit
- Do not turn diagnosis mode selector

- When installing large capacity wireless equipment or a vehicle phone, be sure to observe the following as it may adversely affect electronic control systems depending on its installation location

- 1) Keep the antenna as far as possible away from the electronic control units
- 2) Also keep the antenna feeder line more than 20 cm (7.9 in) away from the harness of electronic controls. Do not let them run parallel for a long distance
- 3) Adjust the antenna and feeder line so that the standing-wave ratio can be kept smaller

- Do not apply battery power directly to injectors
- Do not remove the fuel temperature sensor from the pressure regulator. Replace as an assembly

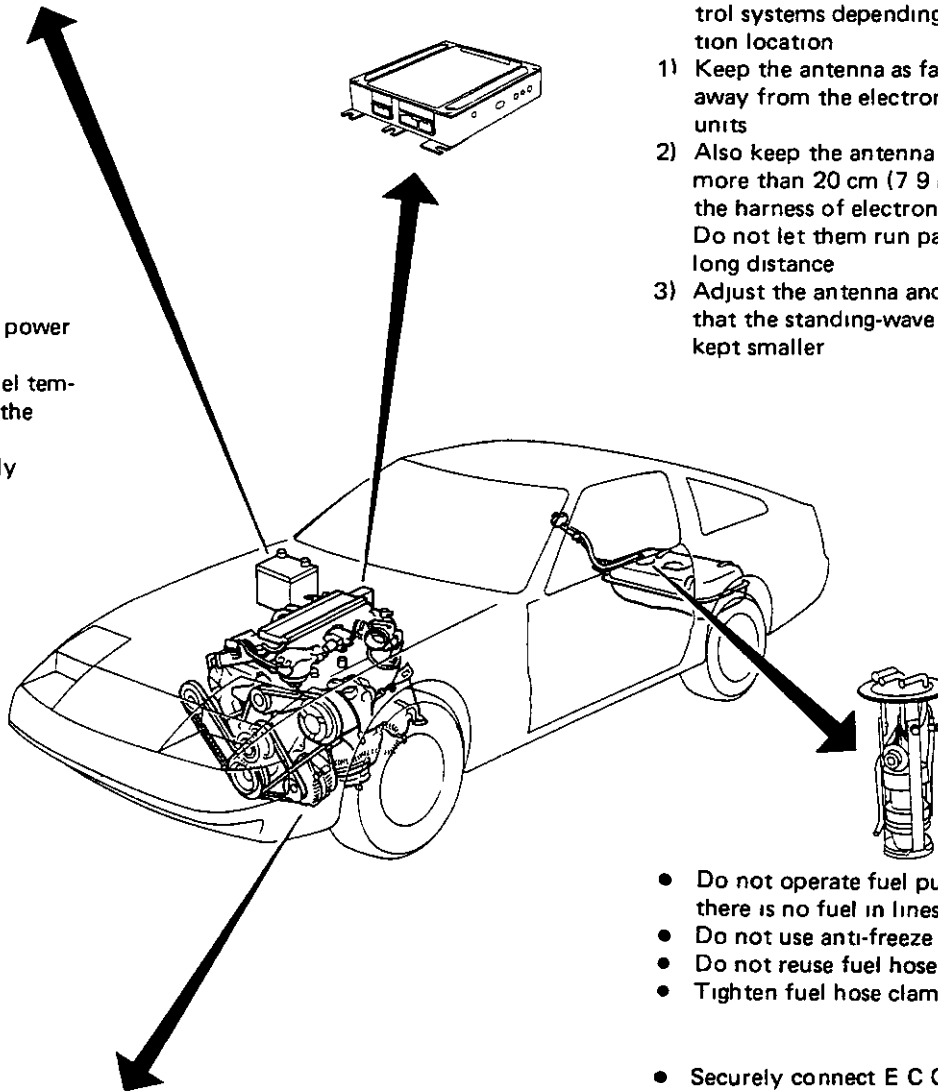

- Handle air flow meter carefully to avoid damage
- Do not disassemble air flow meter
- Do not clean air flow meter with any type of detergent
- Even a slight leak in the air intake system can cause serious problems

- Do not disassemble auxiliary air control valve (VG30ET engine)



- Do not shock or jar the crank angle sensor

- Do not depress accelerator pedal when starting
- Immediately after starting, do not rev up engine unnecessarily
- Do not rev up engine just prior to shutdown

- Do not operate fuel pump when there is no fuel in lines
- Do not use anti-freeze agents in fuel
- Do not reuse fuel hose clamps
- Tighten fuel hose clamps sufficiently

- Securely connect E C C S harness connectors. A poor connection can cause an extremely high (surge) voltage to develop in coil and condenser, thus resulting in damage to IC circuit
- Keep E C C S harness at least 10 cm (3.9 in) away from adjacent harnesses, to prevent an E C C S system malfunction due to reception of external noise, degraded operation of IC circuit, etc
- Keep E C C S parts and harnesses dry
- Before removing parts, turn off ignition switch and then disconnect battery ground cable

SEF600B

COMPONENT PARTS LOCATION

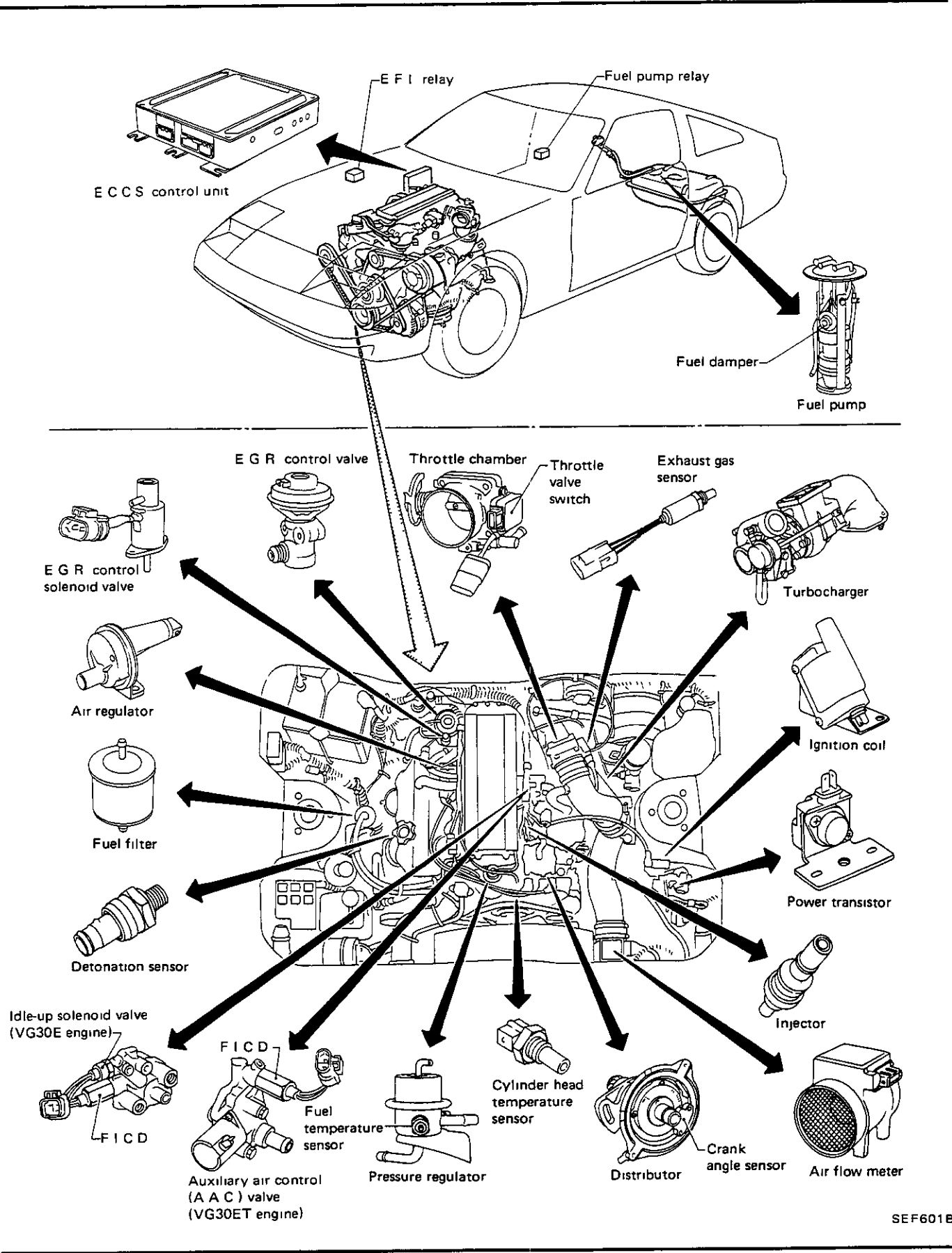

SEF601B

E.C.C.S. DIAGRAM

VG30E Engine (Without turbocharger)

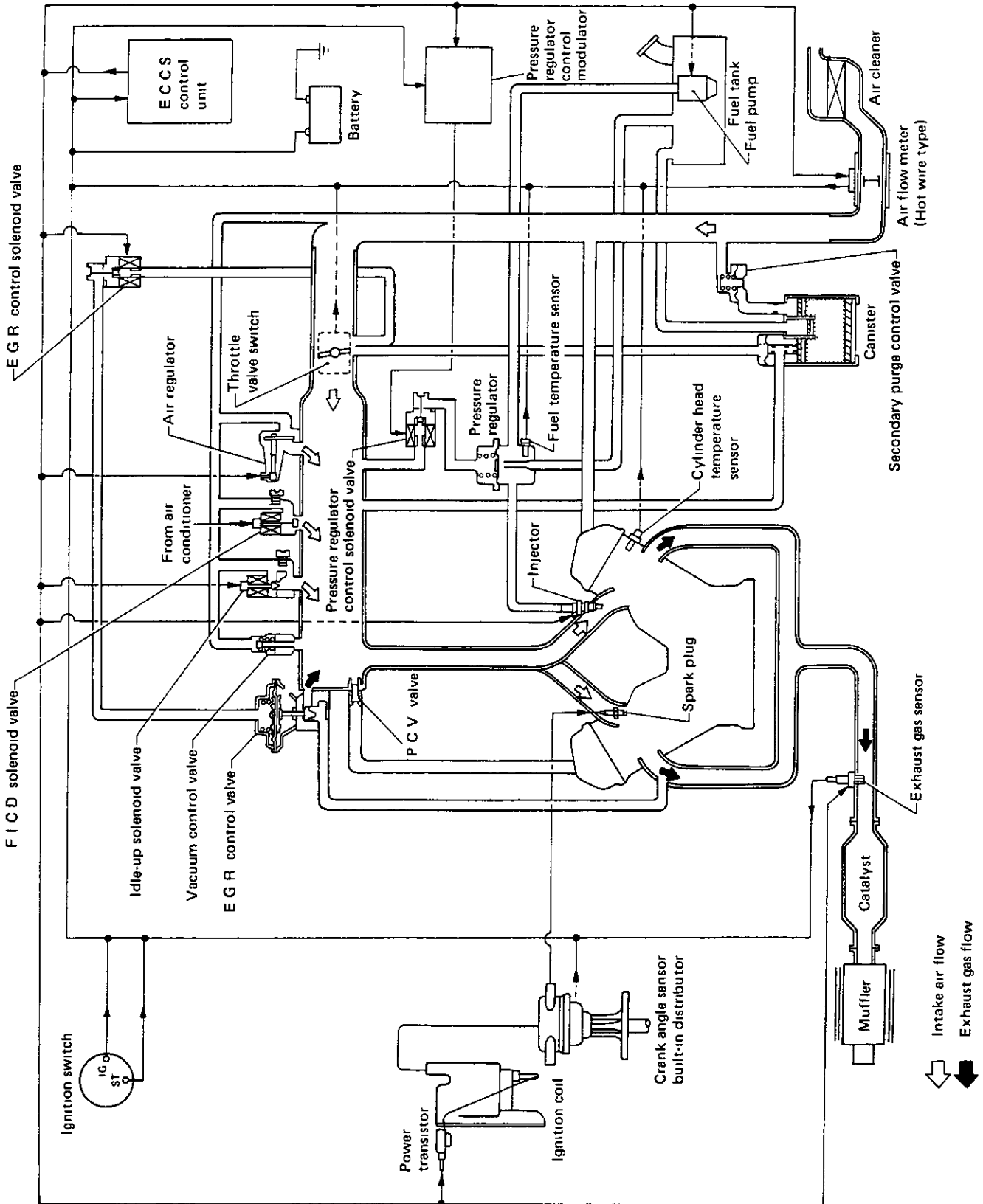

SEF602B

E.C.C.S. DIAGRAM

VG30ET Engine (With turbocharger)

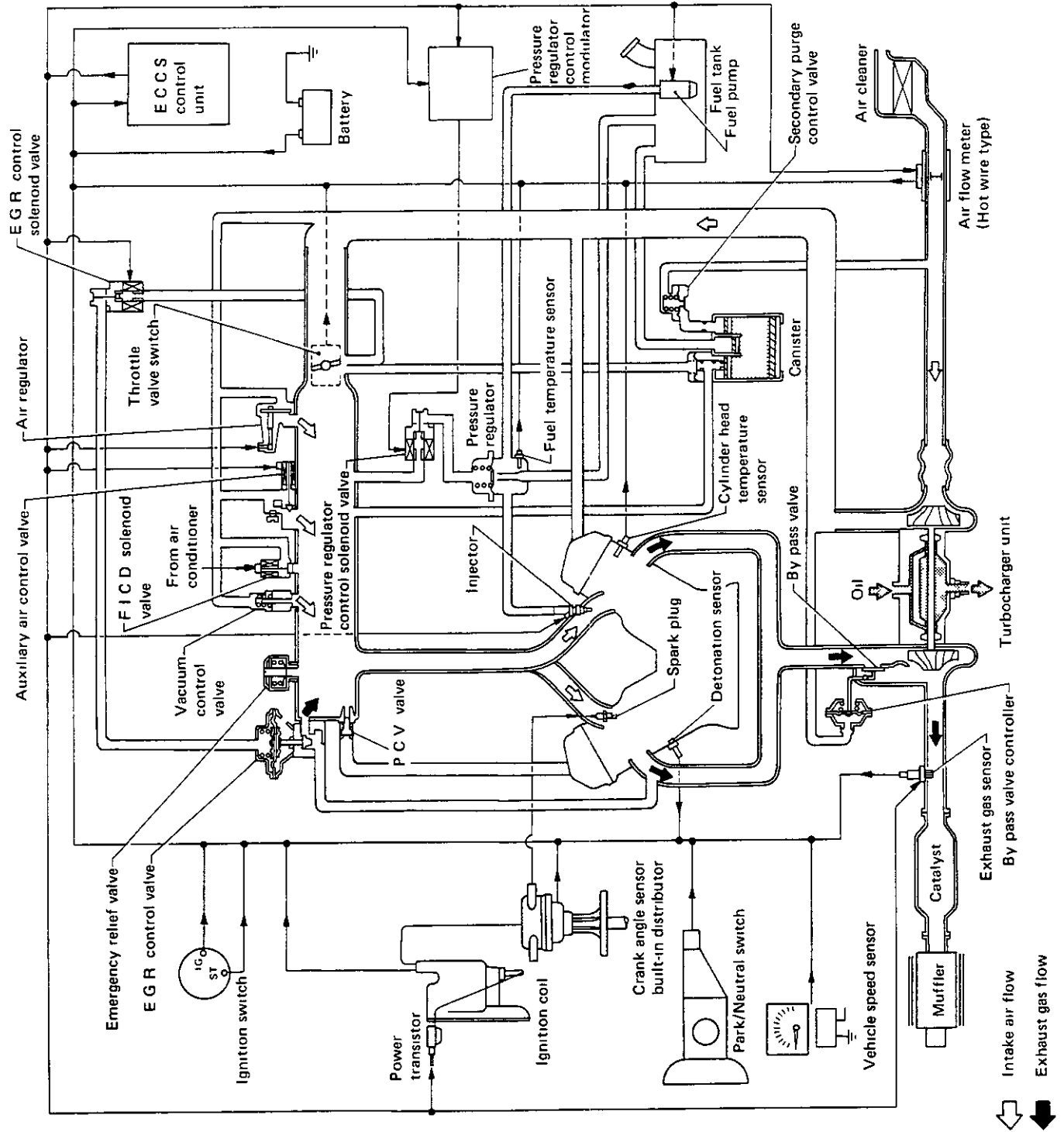

SEF603B

E.C.C.S. CHART

VG30E Engine (Without turbocharger)

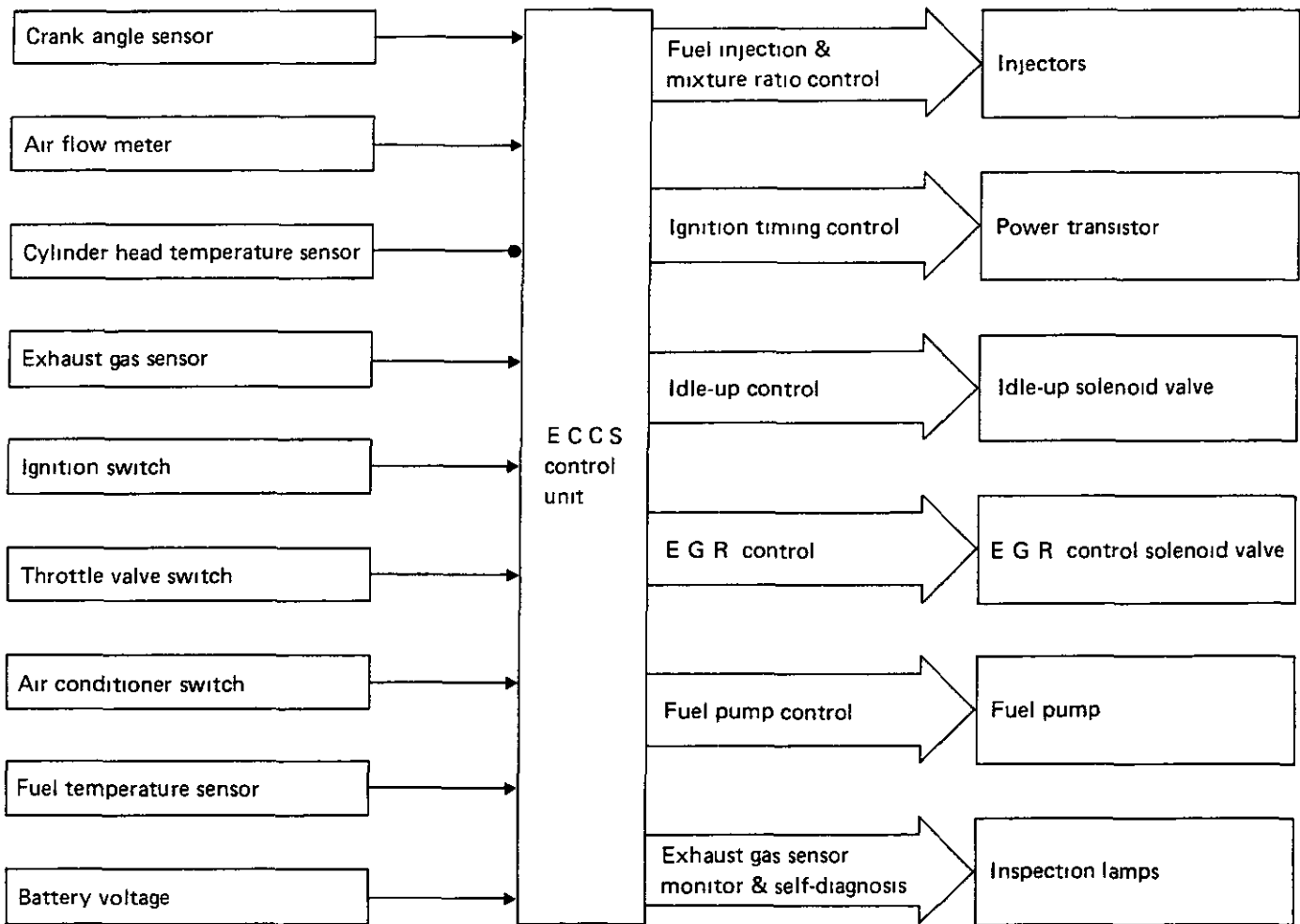

E.C.C.S. CHART

VG30ET Engine (With turbocharger)

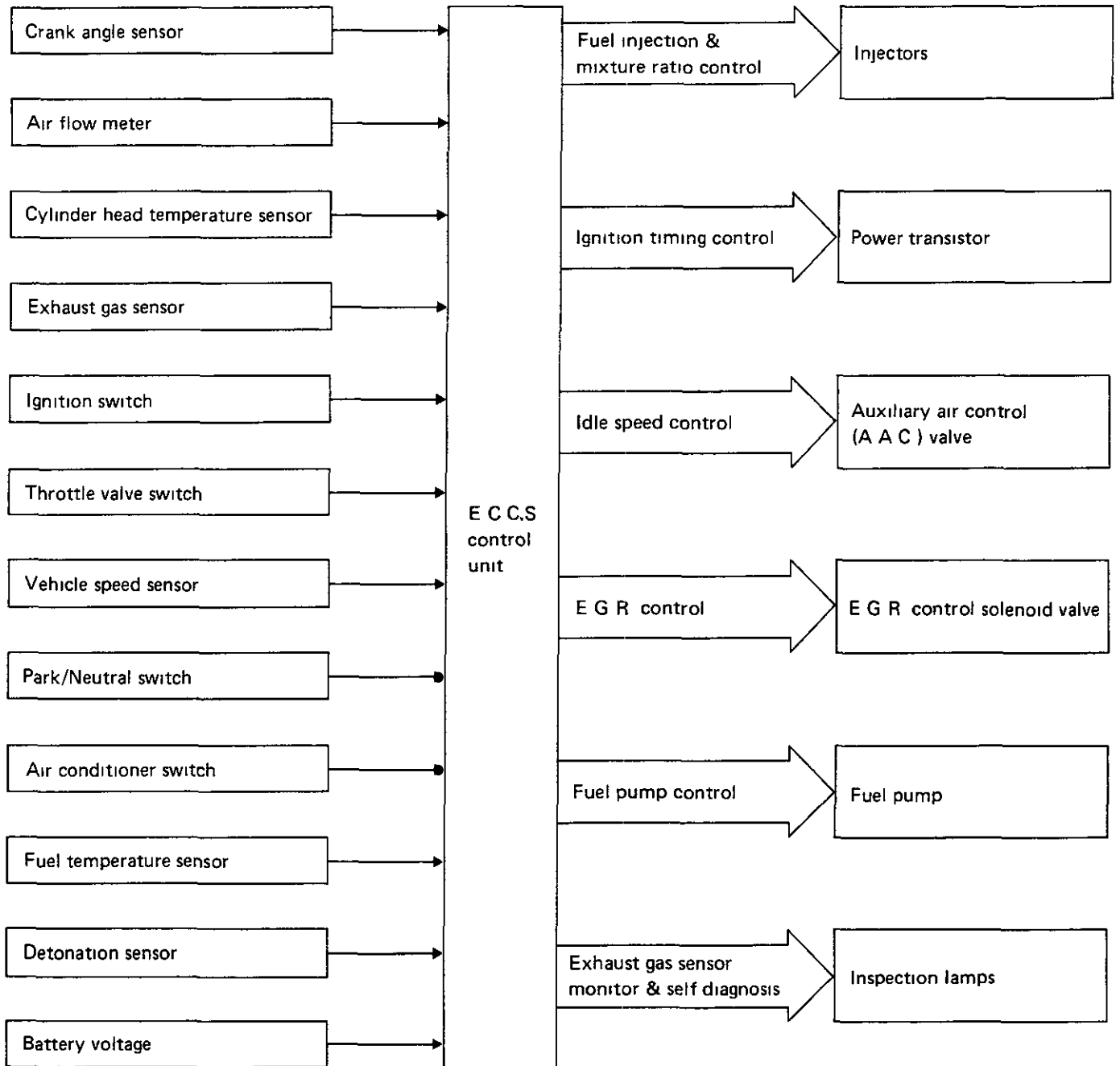

E.C.C.S. WIRING DIAGRAM

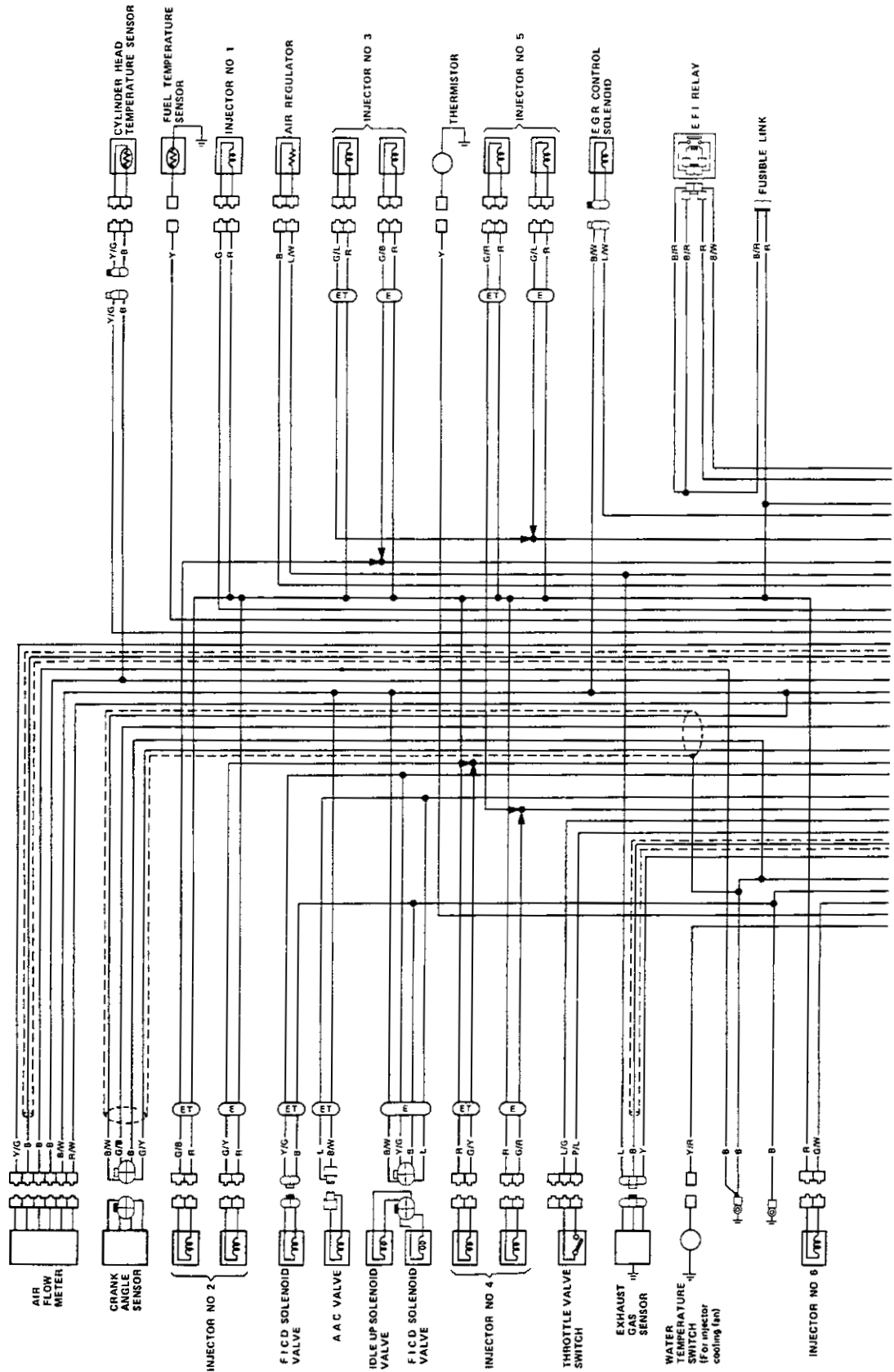

E.C.C.S. WIRING DIAGRAM

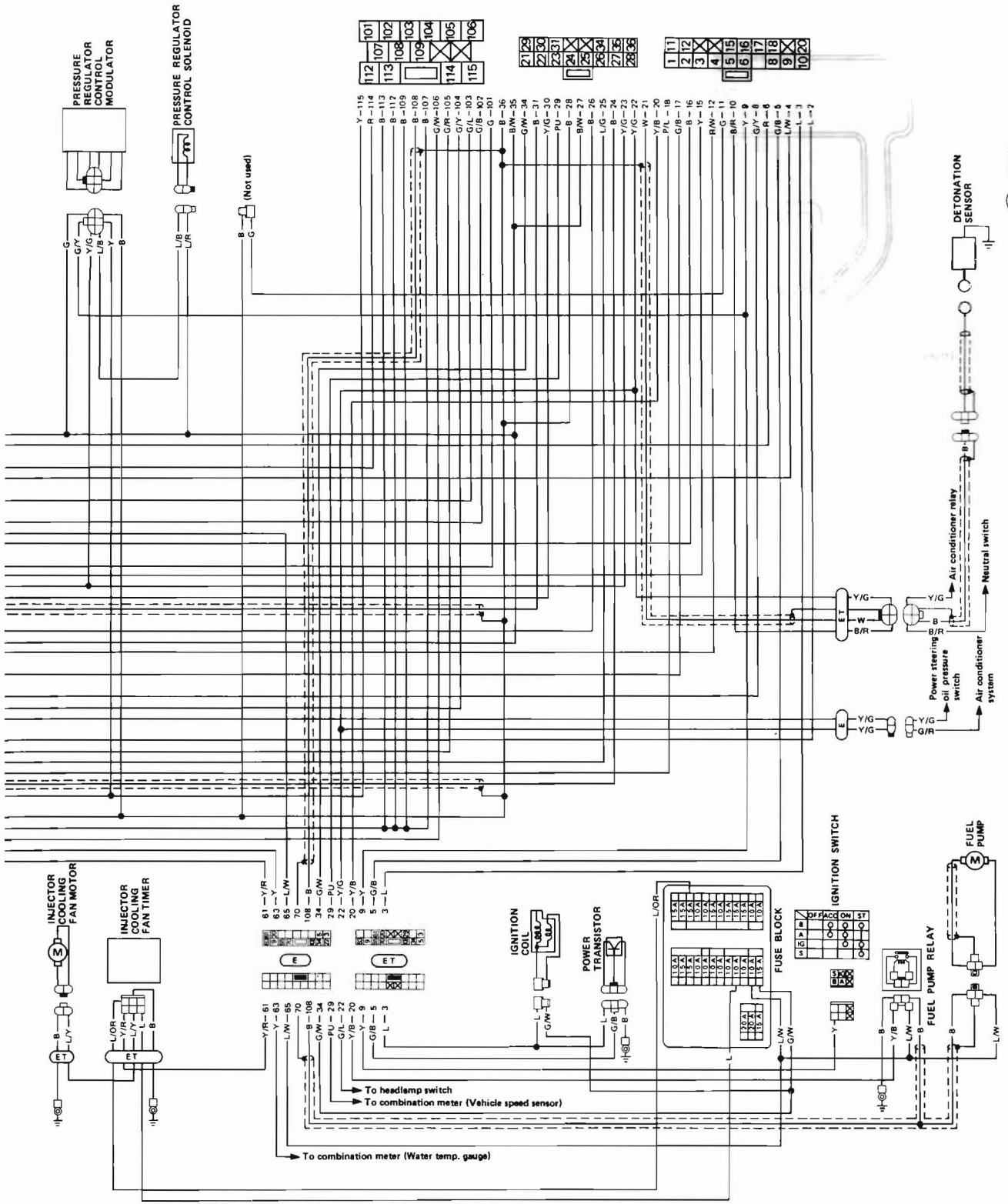

: VG30E engine
 : VG50E engine

FUEL FLOW SYSTEM DESCRIPTION

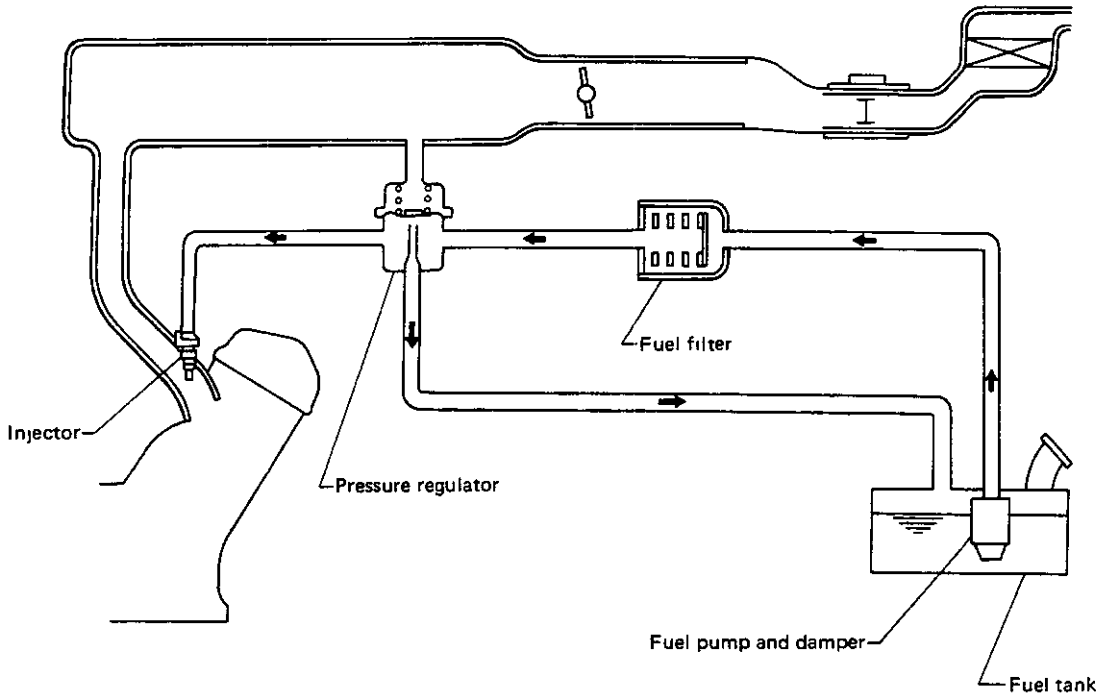

SEF604B

The amount of fuel to be injected is determined by the injection pulse duration as well as by a pressure difference between fuel pressure and intake manifold vacuum pressure. The E.C.C.S. control unit controls only the injection pulse duration. For this reason, the pressure difference between the fuel pressure and intake manifold vacuum pressure should be maintained at a constant level. Since the intake manifold vacuum pressure varies with engine operating conditions, a pressure regulator is placed in the fuel line to regulate the fuel pressure in response to changes in the intake manifold vacuum pressure.

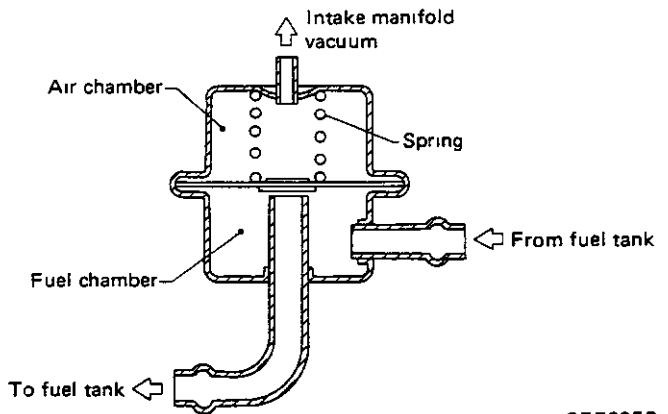

SEF605B

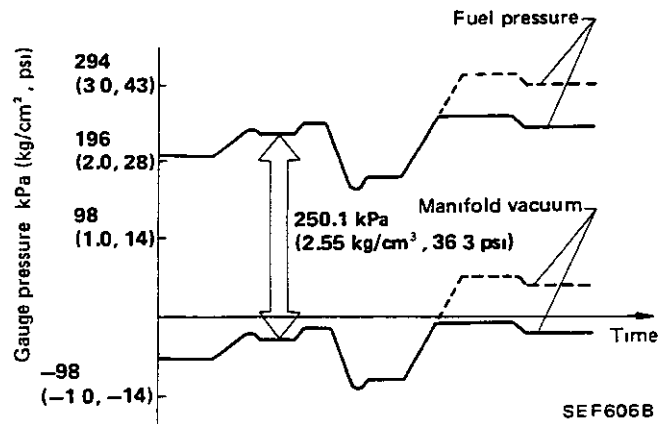

SEF606B

AIR FLOW SYSTEM DESCRIPTION

VG30E engine (Without turbocharger)

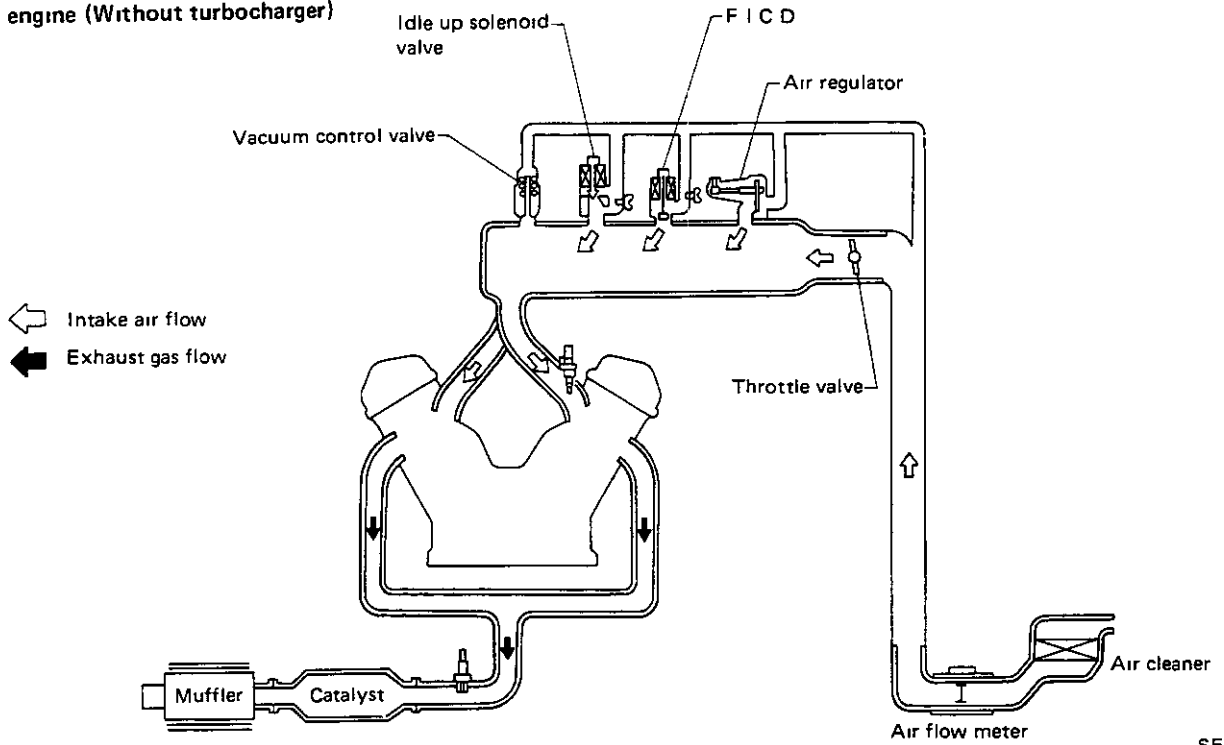

SEF607B

VG30ET engine (With turbocharger)

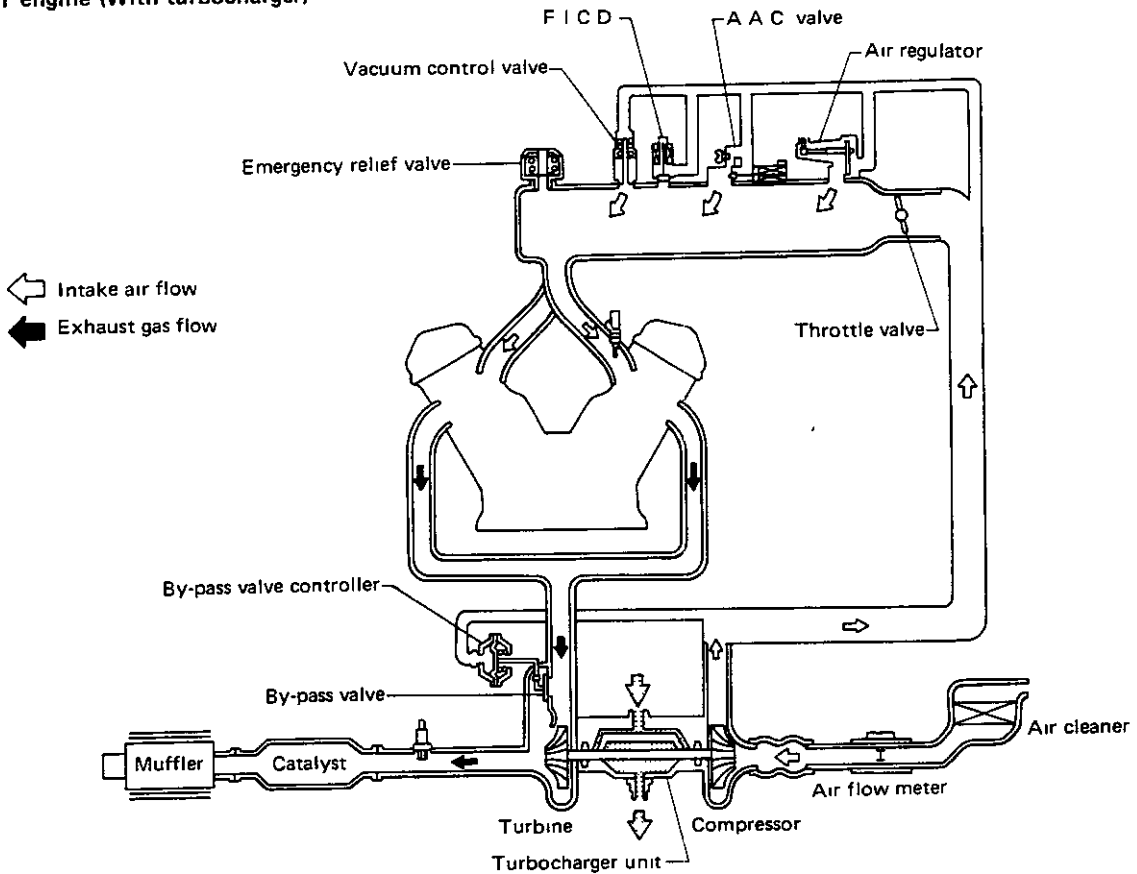

SEF608B

AIR FLOW SYSTEM DESCRIPTION

TURBOCHARGER

The turbocharger is installed on the exhaust manifold. This system utilizes exhaust gas energy to spin the turbine wheel which is directly connected to the compressor wheel. The compressor supplies pressurized air through the throttle chamber into the intake manifold. Thus, the turbocharger increases charging efficiency and thereby increases power and torque.

To prevent an excessive rise in the supercharging pressure, the turbine speed is maintained within a safe range by controlling the amount of exhaust gas that passes through the turbine. This system consists of a by-pass valve which allows some of the exhaust gas to by-pass the turbine and to flow directly into the exhaust tube.

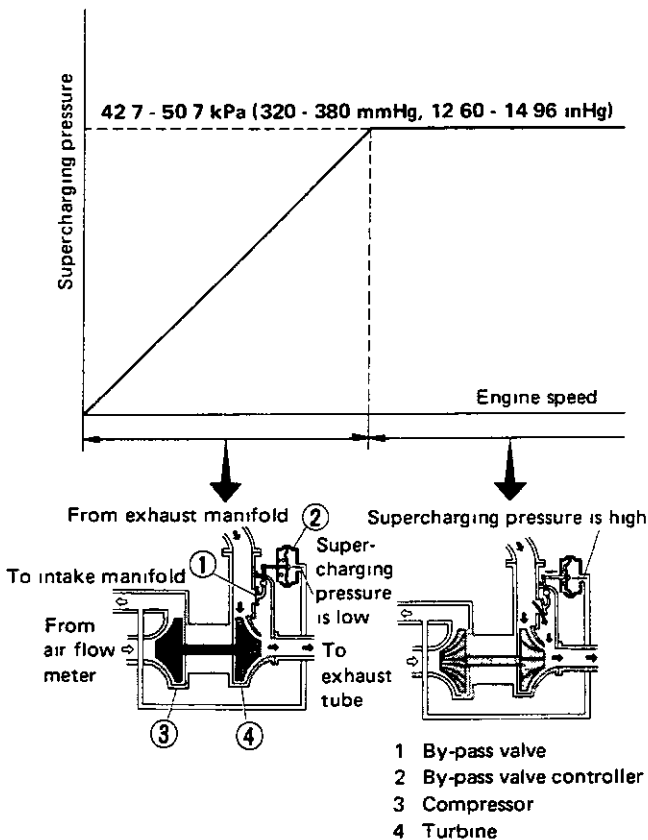

SEF609B

EMERGENCY RELIEF VALVE

To prevent an abnormal rise in supercharging pressure, and possible engine damage, in case the by-pass valve fails to open properly, an emergency relief valve is provided as a safety device on the intake manifold.

When the pressure in the intake manifold is below 52.0 kPa (390 mmHg, 15.35 inHg)

When the pressure in the intake manifold is above 52.0 kPa (390 mmHg, 15.35 inHg)

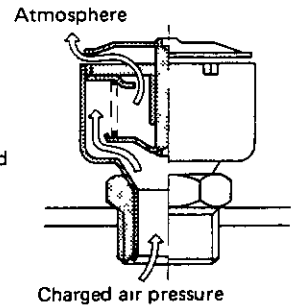
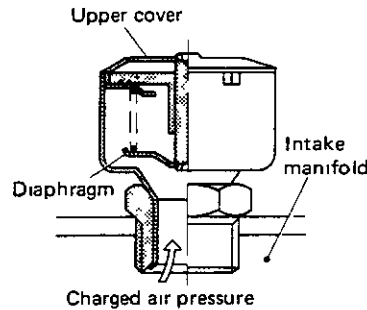

SEF610B

E.C.C.S. DESCRIPTION

E.C.C.S. Components

E C C S. CONTROL UNIT

The E C C S control unit consists of a micro-computer, connectors for signal input and output and power supply, inspection lamps and diagnostic mode selector. The control unit controls the amount of fuel that is injected, ignition timing, idle speed, E G R, fuel pump operation, and feedback of the mixture ratio.

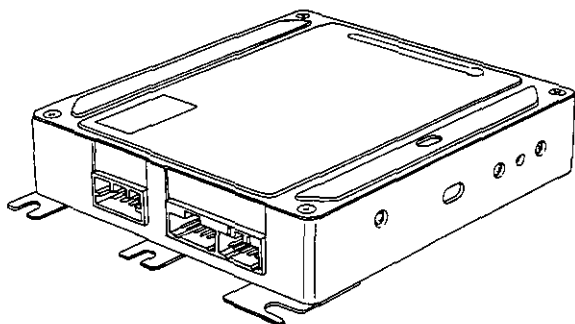

SEF611B

CRANK ANGLE SENSOR

Crank angle sensor is a basic signal sensor for the entire E C C S. It monitors engine speed and piston position, and it sends signals to the E C C S control unit for control of fuel injection, ignition timing, idle speed, fuel pump operation and E G R operation.

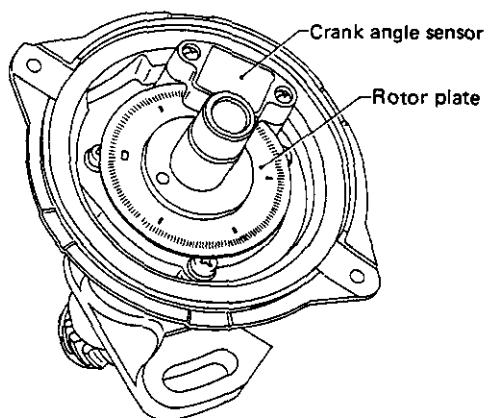

SEF612B

Crank angle sensor has rotor plate and wave forming circuit. Rotor plate has 360 slits for 1° signal (engine speed signal) and 6 slits for 120° signal (crank angle signal). Light Emitting Diodes (L E D) and Photo Diodes are built into wave forming circuit.

When signal rotor plate passes the space between the L E D and Photo Diode, the slit of the signal rotor plate alternately cuts the light which is sent to the photo diode from the L E D. This causes an alternative voltage and it is then converted into an on-off pulse by the wave forming circuit, which is sent to the control unit.

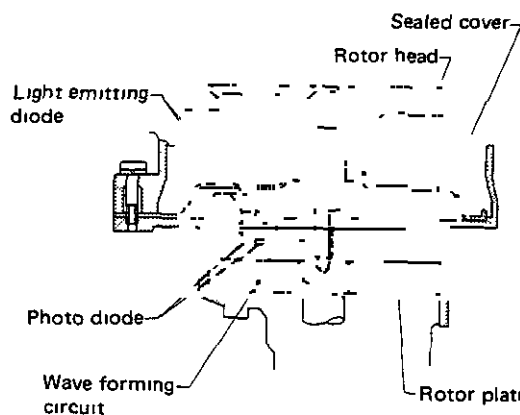

SEF613B

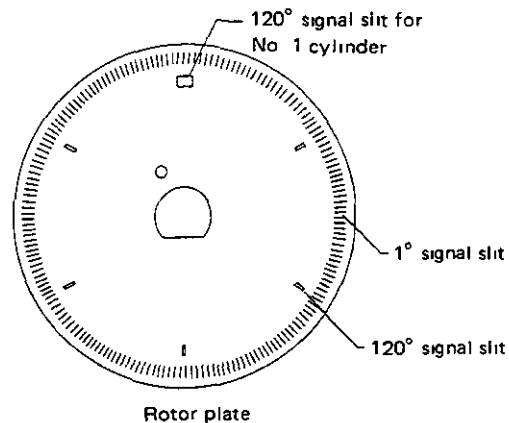

SEF614B

E.C.C.S. DESCRIPTION

E.C.C.S. Components (Cont'd)

AIR FLOW METER

The air flow meter measures the mass flowrate of intake air. Measurements are made in such a manner that the control circuit emits an electrical output signal in relation to the amount of heat dissipated from the hot wire placed in the stream of intake air.

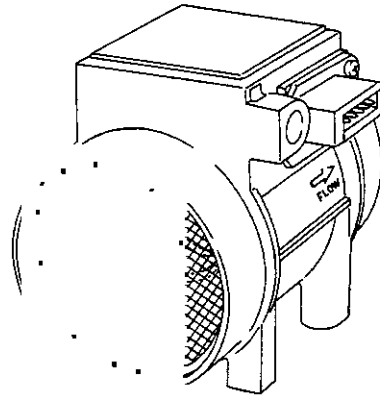

SEF615B

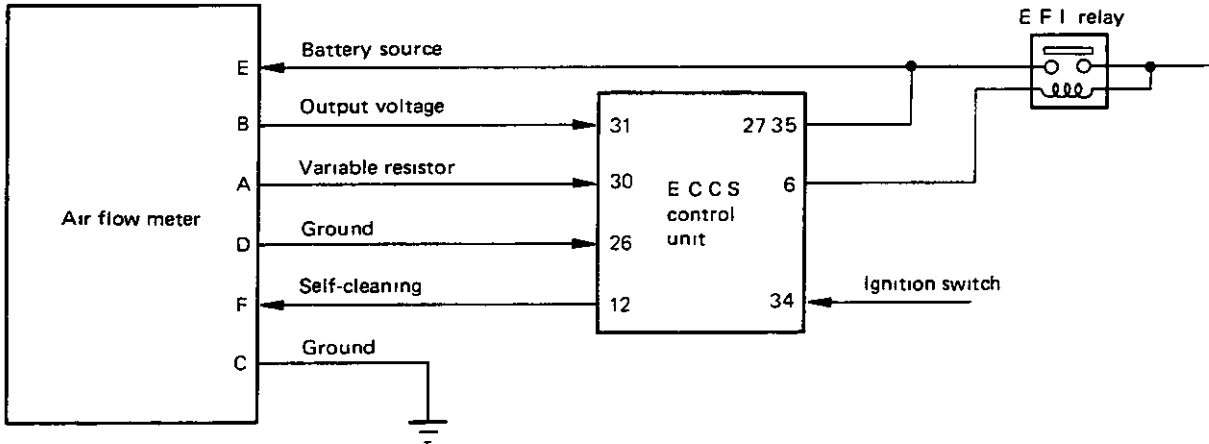

SEF616B

The air flowing around the hot wire removes the heat from the hot wire. The temperature of the hot wire is very sensitive to the mass flowrate of the air. The higher the temperature of the hot wire, the higher its resistance value. This change in the temperature (or. resistance) is determined by the mass flowrate of the air. The control circuit accurately regulates current (I) in relation to the varying resistance value (R_H) so that V_A always equals V_B . The air flow meter transmits an output for voltage V_A to the control unit where the output is converted into an intake air signal.

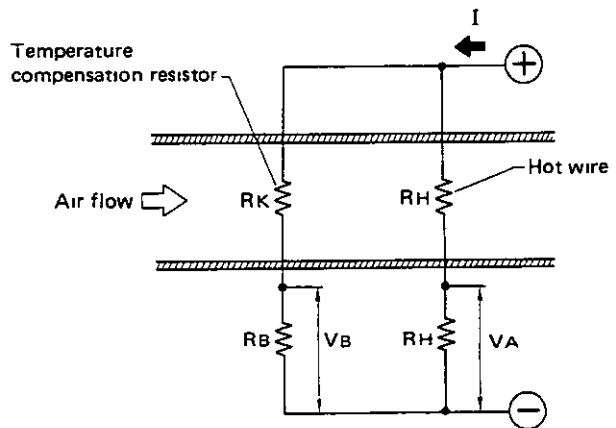

- R_H Hot wire resistance
- R_K Temperature compensation resistance
- R_A, R_B Constant resistance

SEF617B

E.C.C.S. DESCRIPTION

E.C.C.S. Components (Cont'd)

Self-cleaning

After engine is stopped, the E C.C.S control unit heats up the hot wire to approximately 1,000°C (1,832° F) to burn out dust which adhered to the hot wire

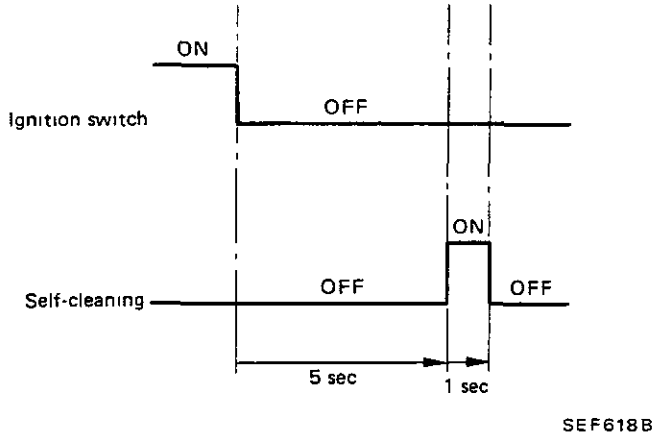

Self-cleaning operation

Condition	Operation
After running engine at above 1,500 rpm After driving vehicle at above 20 km/h (12 MPH) Cylinder head temperature is more than 115°C (239° F)	Operates
Except above	Does not operate

CYLINDER HEAD TEMPERATURE SENSOR

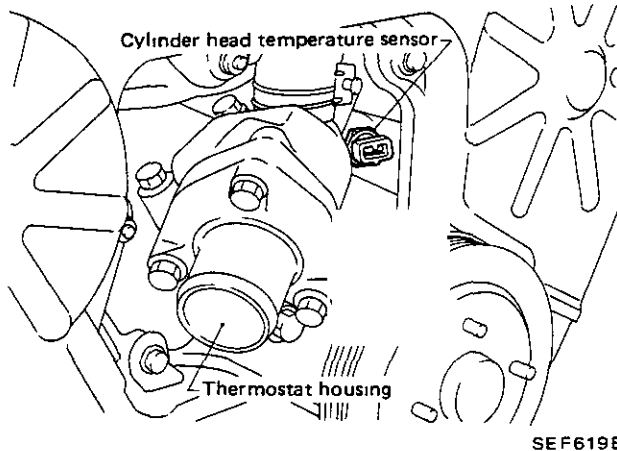

The cylinder head temperature sensor, built into the cylinder head, monitors changes in cylinder head temperature and transmits a signal to the E C C S control unit

The temperature sensing unit employs a thermistor which is sensitive to the change in temperature. Electrical resistance of the thermistor decreases in response to the temperature rise

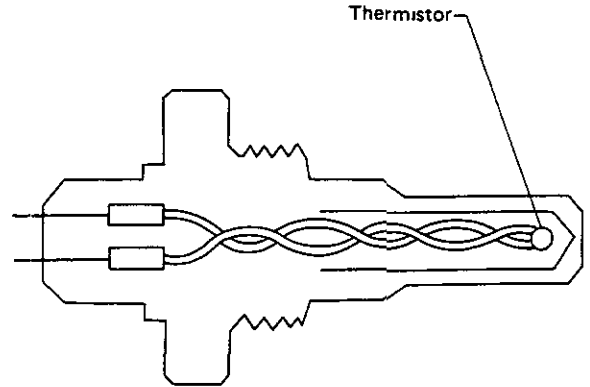

EXHAUST GAS SENSOR

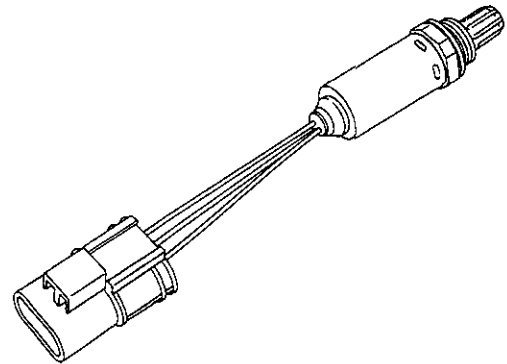

The exhaust gas sensor, which is built into the exhaust manifold, monitors the density of oxygen in the exhaust gas. It consists of a closed-end tube made of ceramic zirconia and other components. Porous platinum electrodes cover the tubes inner and outer surfaces. The closed-end of the tube is exposed to the exhaust gas in the exhaust manifold. The outer surface of the tube contacts the exhaust gas while the inner surface contacts the air

E.C.C.S. DESCRIPTION

E.C.C.S. Components (Cont'd)

In order to ensure the stable performance of the exhaust gas sensor, a ceramic heater is employed inside the zirconia tube

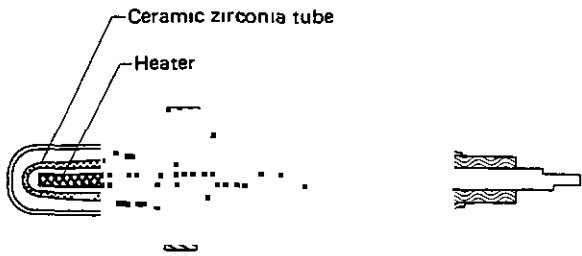

SEF622B

THROTTLE VALVE SWITCH

The throttle valve switch is attached to the throttle chamber and actuates in response to accelerator pedal movement

This switch has idle contact and full throttle contact. The idle contact closes when the throttle valve is positioned at idle and opens when it is at any other position.

The full throttle contact is used only for the electronic controlled automatic transmission

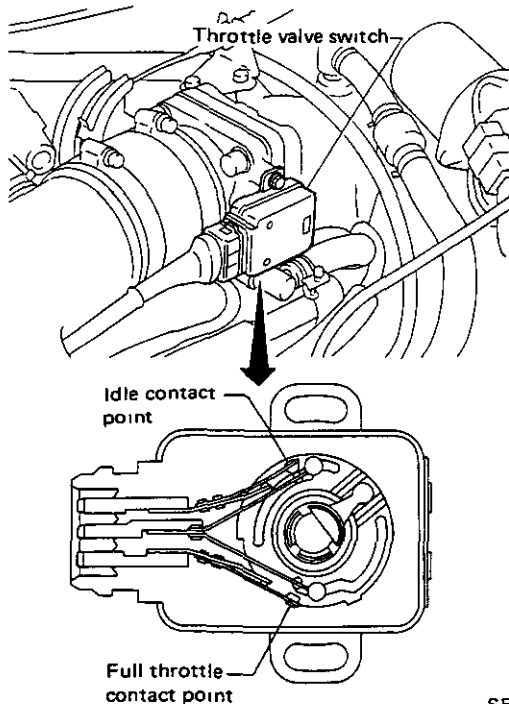

SEF623B

VEHICLE SPEED SENSOR (VG30ET engine only)

The vehicle speed sensor provides a vehicle speed signal to the E.C.C.S. control unit

• Needle type speedometer models

The speed sensor consists of a reed switch, which is installed in the speed meter unit and transforms vehicle speed into a pulse signal.

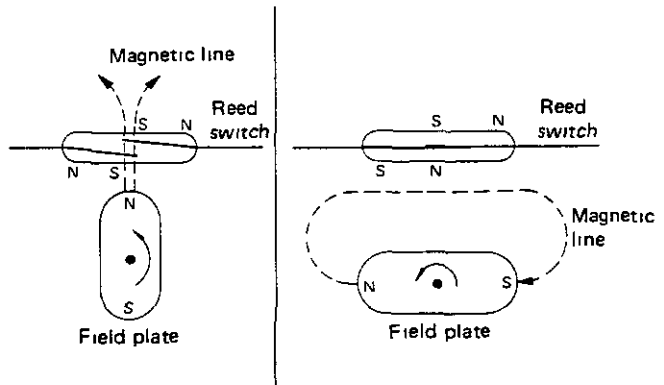

SEF624B

• Digital type speedometer models

The speed sensor consists of an LED, photo diode, shutter and wave forming circuit. Its principle is the same as that of the crank angle sensor

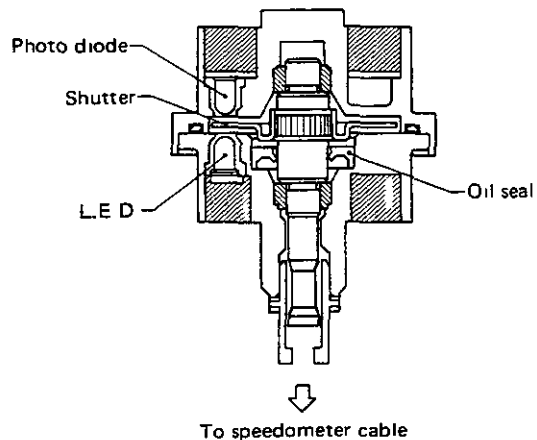

SEF680B

E.C.C.S. DESCRIPTION

E.C.C.S. Components (Cont'd)

FUEL TEMPERATURE SENSOR

The fuel temperature sensor is built into the pressure regulator, and senses fuel temperature. When the fuel temperature is higher than the specified level, the E C C S control unit enriches fuel injected.

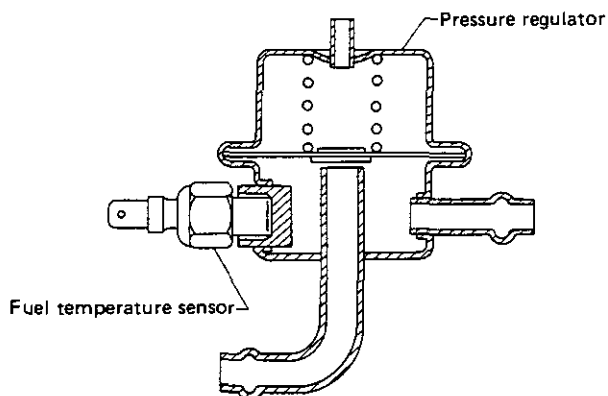

SEF625B

Do not remove fuel temperature sensor from pressure regulator. Always replace as an assembly.

DETONATION SENSOR (VG30ET engine only)

The detonation sensor is attached to the cylinder block and senses engine knocking conditions. A knocking vibration from the cylinder block is applied as pressure to the piezoelectric element. This vibrational pressure is then converted into a voltage signal which is delivered as output.

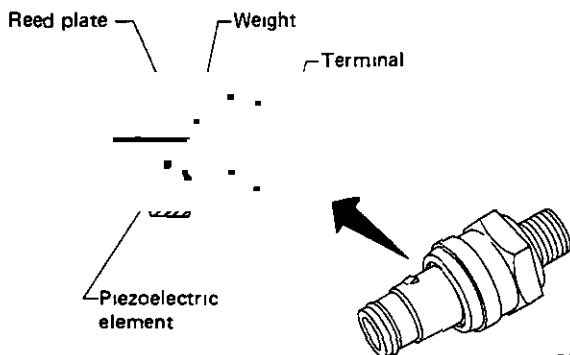

SEF626B

FUEL INJECTOR

The fuel injector is a small, precision solenoid valve. As the E C C S control unit outputs an in-

jection signal to each fuel injector, the coil built into the injector pulls the needle valve back, and fuel is injected through the nozzle to intake manifold. The amount of fuel injected is controlled by the E C C S control unit as an injection pulse duration.

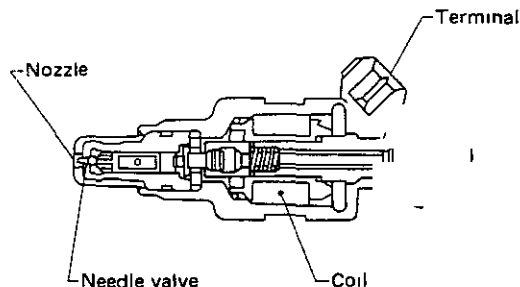

SEF627B

POWER TRANSISTOR

The ignition signal from the E C C S control unit is amplified by the power transistor, which connects and disconnects the coil primary circuit to induce the proper high voltage in the secondary circuit.

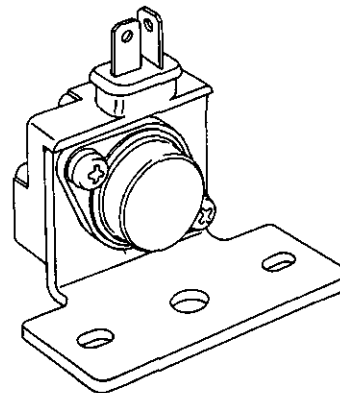

IGNITION COIL

The ignition coil is a mold type.

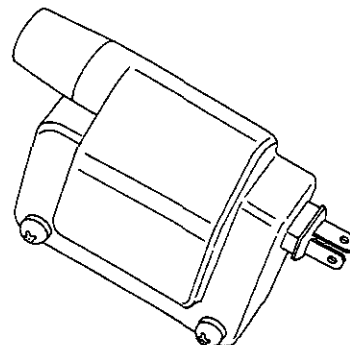

E.C.C.S. DESCRIPTION

E.C.C.S. Components (Cont'd)

AUXILIARY AIR CONTROL (A.A.C) VALVE (VG30ET engine)

The A A C valve is attached to the intake collector. The E C C S control unit actuates A A C valve by ON/OFF pulse of approximately 160 Hz. The longer that ON duty is left on, the larger the amount of air that will flow through the A A C valve.

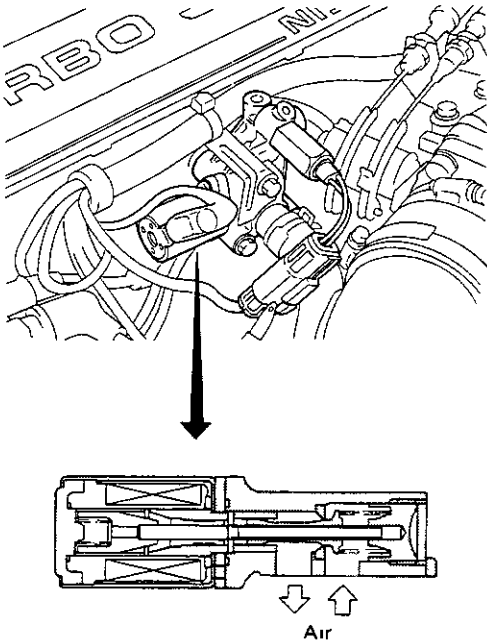

SEF630B

IDLE-UP SOLENOID VALVE (VG30E engine)

The idle-up solenoid valve is attached to the intake collector. The solenoid valve actuates to stabilize idle speed when engine load is heavy because of electric load, power steering oil pump, etc.

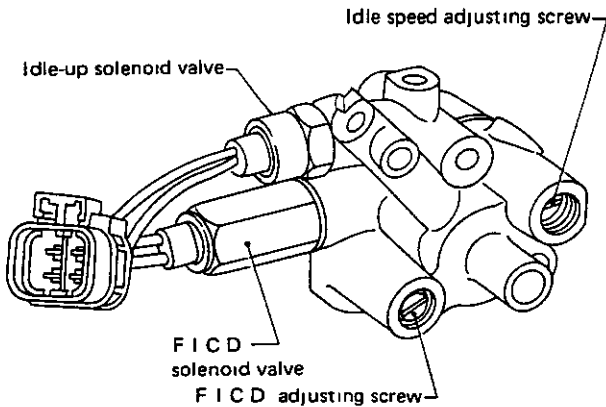

SEF631B

E G R CONTROL VALVE

The E G R. control valve controls the quantity of exhaust gas to be led to the intake manifold through vertical movement of the taper valve connected to the diaphragm, to which vacuum is applied in response to the opening of the throttle valve.

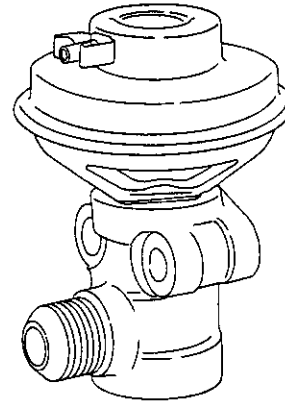

SEF632B

When installing the E.G.R. guide tube, be careful of its direction. Otherwise the distribution efficiency of the exhaust gas will be reduced.

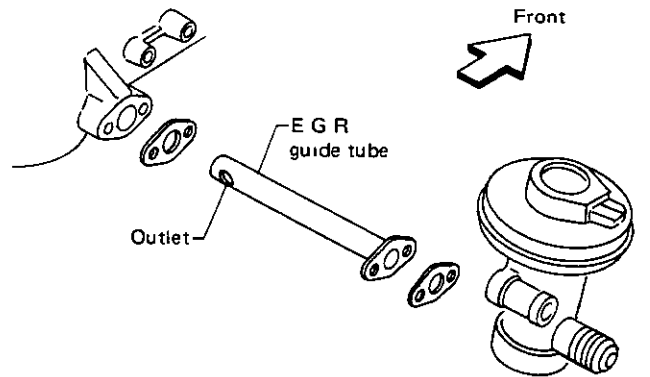

SEF689B

E.C.C.S. DESCRIPTION

E.C.C.S. Components (Cont'd)

E.G.R. CONTROL SOLENOID VALVE

E G R control solenoid valve cuts intake manifold vacuum signal for E G R control. The solenoid valve actuates in response to the ON/OFF signal from the E C.C.S control unit. When the solenoid is off, vacuum signal from intake manifold is fed into the E G R control valve. As the control unit outputs an ON signal, the coil pulls the plunger downward, and cuts the vacuum signal.

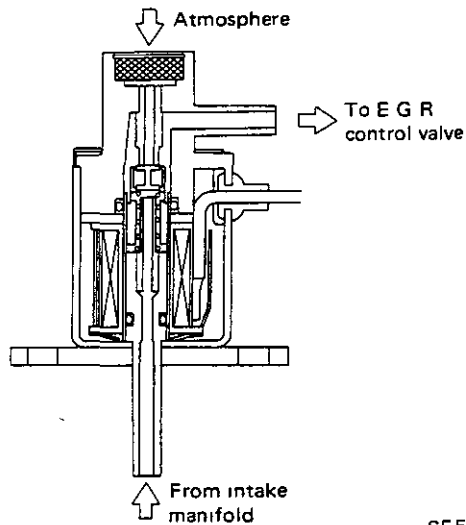

FUEL PUMP

The fuel pump, which is located in the fuel tank, is a wet type pump where the vane rollers are directly coupled to a motor which is filled with fuel.

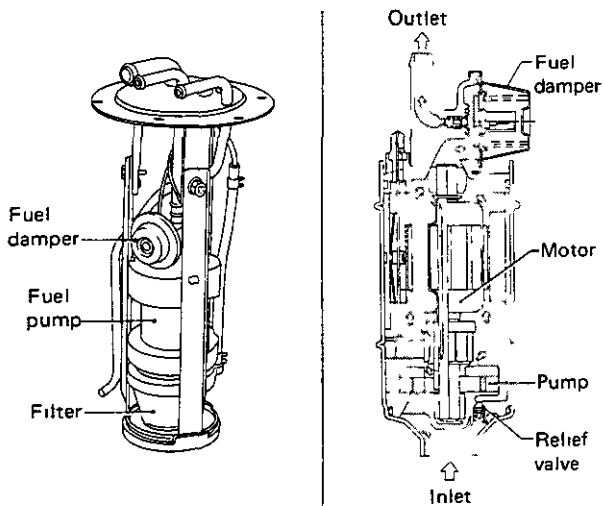

AIR REGULATOR

Air regulator gives an air by-pass when the engine is cold for the purpose of a fast idle during warm-up.

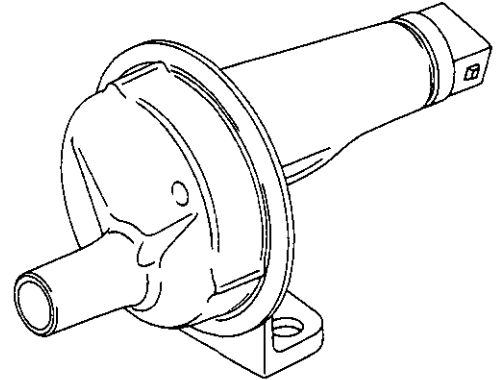

SEF635B

A bimetal, heater and rotary shutter are built into the air regulator. When the bimetal temperature is low, the air by-pass port is open. As the engine starts and electric current flows through a heater, the bimetal begins to rotate the shutter to close off the by-pass port. The air passage remains closed until the engine is stopped and the bimetal temperature drops.

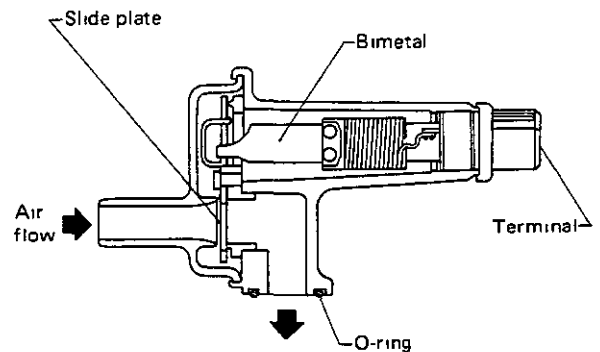

E.C.C.S. DESCRIPTION

Fuel Injection Control

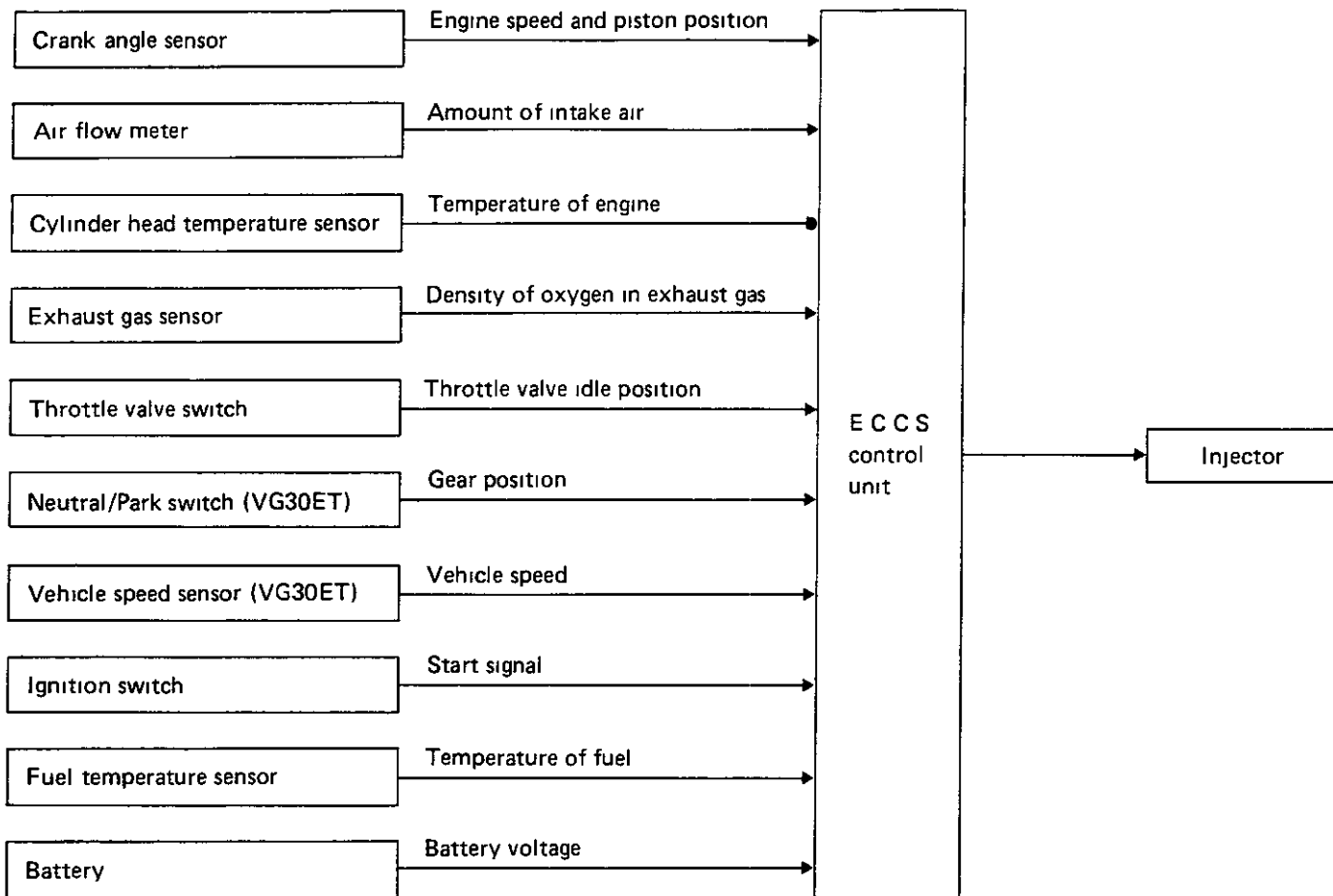

The E.C.C.S. control unit calculates basic injection pulse width by processing signals from crank angle sensor and air flow meter. Receiving signals from each sensor which detects various engine conditions, E.C.C.S. control unit adds various enrichments, which are pre-programmed in the control unit, to the basic injection amount. Thus, the optimum amount of fuel is injected through the injectors.

1) Fuel enrichment

In the following each conditions, fuel is enriched

- During warm-up
- When starting
- After idle
- When accelerating
- With heavy load
- When fuel temperature is high

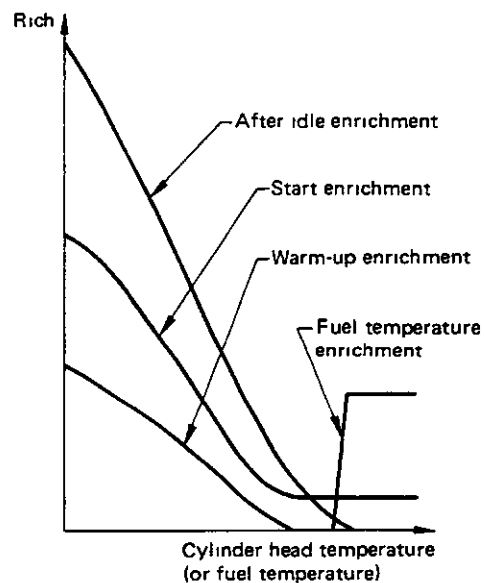

SEF637B

Enrichment rates for "when accelerating" and "with heavy load" are pre-programmed for engine speed and basic injection pulse width

E.C.C.S. DESCRIPTION

Fuel Injection Control (Cont'd)

2) Fuel shut-off

Fuel shut-off is accomplished under the following conditions:

a) During deceleration

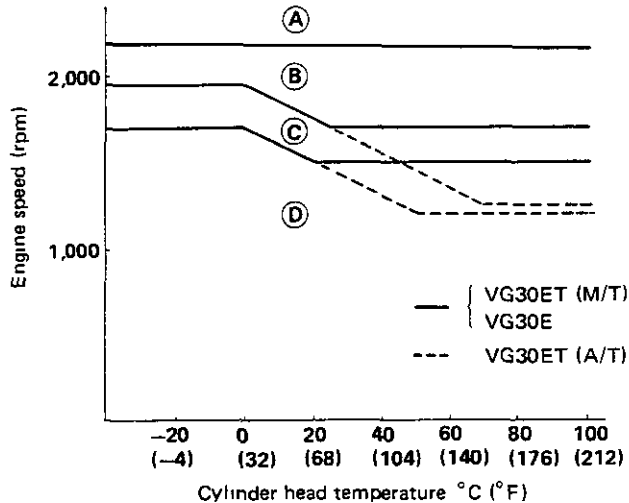

	Fuel shut-off zone	Fuel recovery zone
Deceleration from A	B and C	D
Deceleration from B	C	D
Deceleration from C or D	—	—

b) High engine speed

When engine speed is more than 6,500 rpm, fuel is shut-off for safety reasons

c) High vehicle speed (VG30ET engine only)

When vehicle speed is more than 220 km/h (137 MPH), fuel is shut-off for safety reasons

3) Mixture ratio feedback control

Mixture ratio feedback system is designed to control the mixture ratio precisely to the stoichiometric point so that the three-way catalyst can minimize CO, HC and NO_x emissions simultaneously. This system uses exhaust gas sensor located in the exhaust manifold to give an indication of whether the air-fuel ratio is richer or leaner than the stoichiometric point. The control unit adjusts the injection pulse width according to the sensor voltage so the mixture ratio will be within the narrow window around the stoichiometric air fuel ratio.

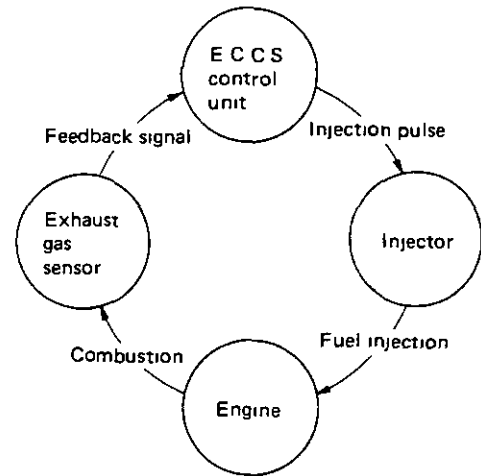

SEF639B

However, this system will open under the following conditions:

- When starting engine.
- When engine and exhaust gas sensor is cold
- When driving at high speeds or under heavy load.
- At idle
- When exhaust gas sensor monitors a too lean condition for more than 10 seconds.
- When fuel shut-off is in operation

E.C.C.S. DESCRIPTION

— Fuel Injection Control (Cont'd)

4) Simultaneous injection and group injection

On the VG30ET engines, two types of fuel injection systems are used – simultaneous injection and group injection. In the former, fuel is injected into all six cylinders simultaneously twice each engine cycle

In other words, pulse signals of the same width are simultaneously transmitted from the E.C.C.S. control unit to the six injectors two times for each engine cycle

In the group injection system, six injectors are divided into two groups – No 1, No. 2, No. 3 and No 4, No 5, No 6 And fuel is injected into each group separately once each engine cycle

• Group injection

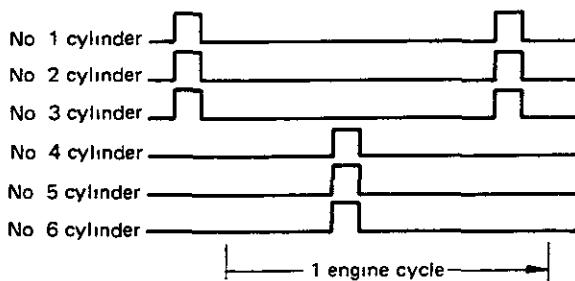

• Simultaneous injection

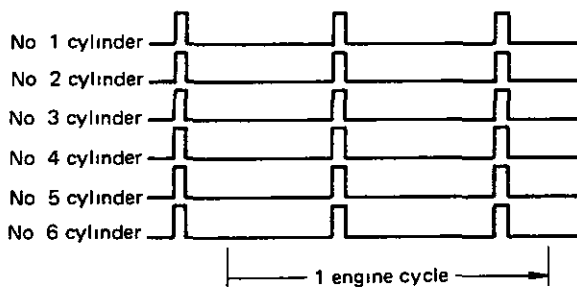

SEF640B

When any of the following conditions are met, fuel injection shifts to simultaneous injection from group injection.

- Engine speed is more than 3,000 rpm
- Injection pulse duration is more than 6.5ms
- Cylinder head temperature is below 60°C (140°F)

E.C.C.S. DESCRIPTION

Ignition Timing Control

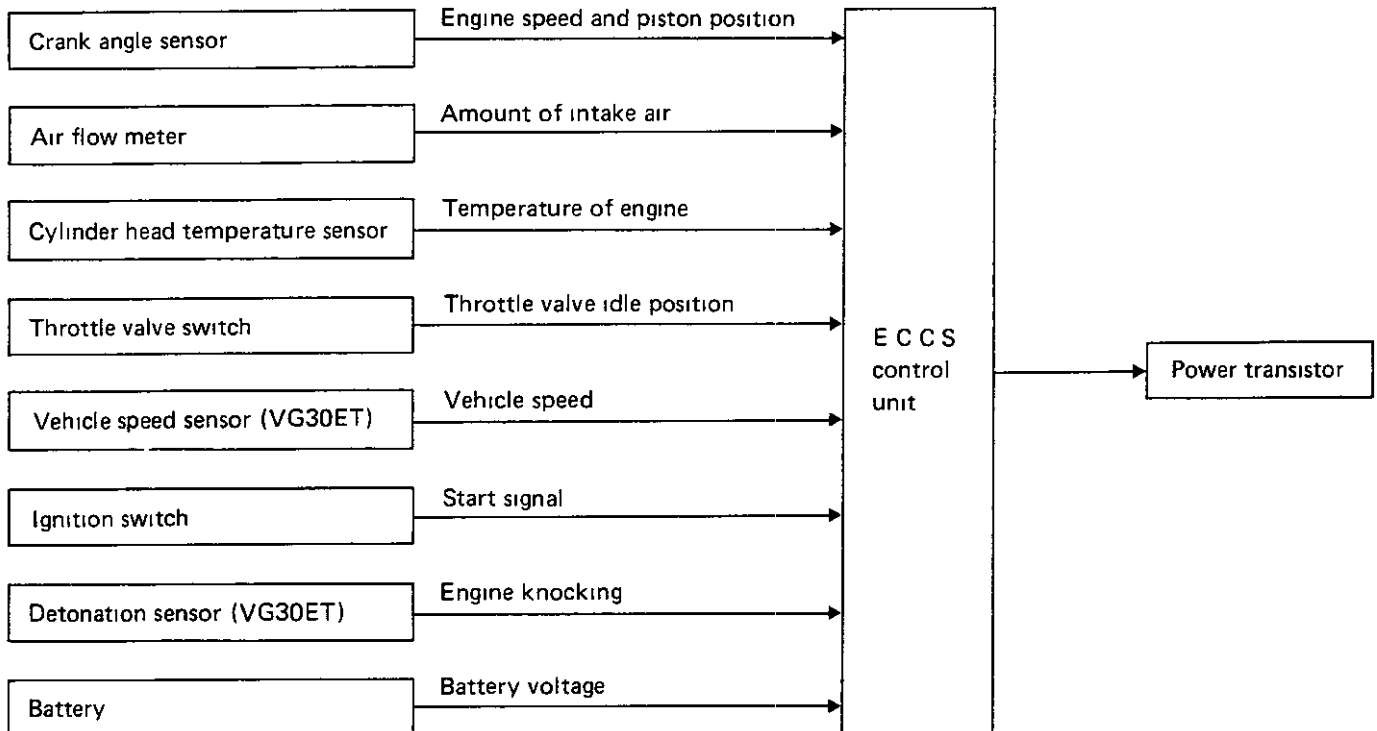

Ignition timing is controlled, corresponding to the engine operating conditions, by the E.C.C.S. control unit that is, as the optimum ignition timing in each driving condition has been pre-programmed in the control unit, the ignition timing is determined by electrical signals processed in the unit.

The signal from E.C.C.S. control unit is transmitted to power transistor, and controls ignition timing.

The retard system by detonation sensor is designed only for emergencies on VG30ET engines. The basic ignition timing is pre-programmed within the anti-knocking zone, even if recommended fuel is used under dry conditions. Consequently, the retard system does not operate under normal driving conditions.

However, if there engine knocking occurs, the detonation sensor monitors knocking condition and the signal is transmitted to the E.C.C.S. control unit. After receiving it, the control unit retards the ignition timing to avoid the knocking condition.

E.C.C.S. DESCRIPTION

Idle-up Control (VG30E engine)

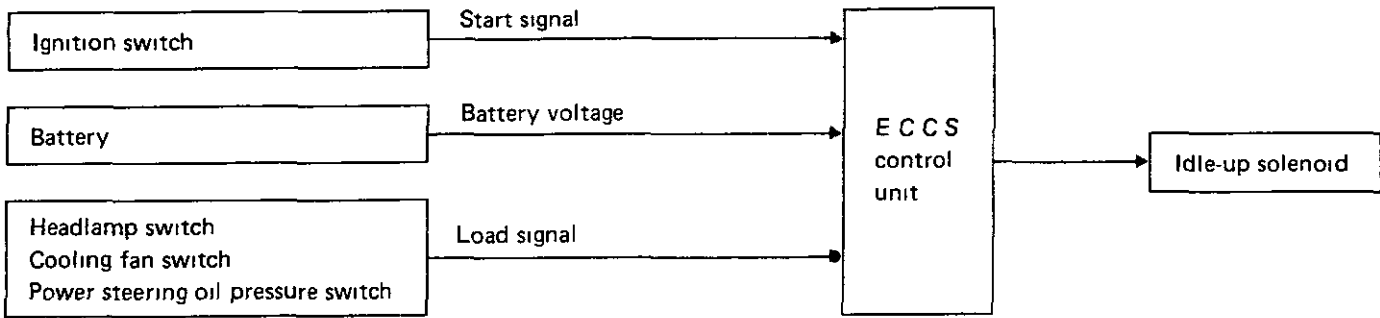

The idle speed is compensated by the E C C S control unit to prevent rough idle when any of the following conditions are met

The control unit senses the idle condition, and determines ON/OFF signal. The signal from control unit is transmitted to the idle-up solenoid valve to stabilize idle speed.

Condition	Idle-up solenoid operation
During engine start 20 seconds after engine start Battery voltage is below 12V Headlamp switch ON Cooling fan switch ON Power steering oil pressure switch ON	ON
Except above	OFF

E.C.C.S. DESCRIPTION

Idle Speed Control (VG30ET engine)

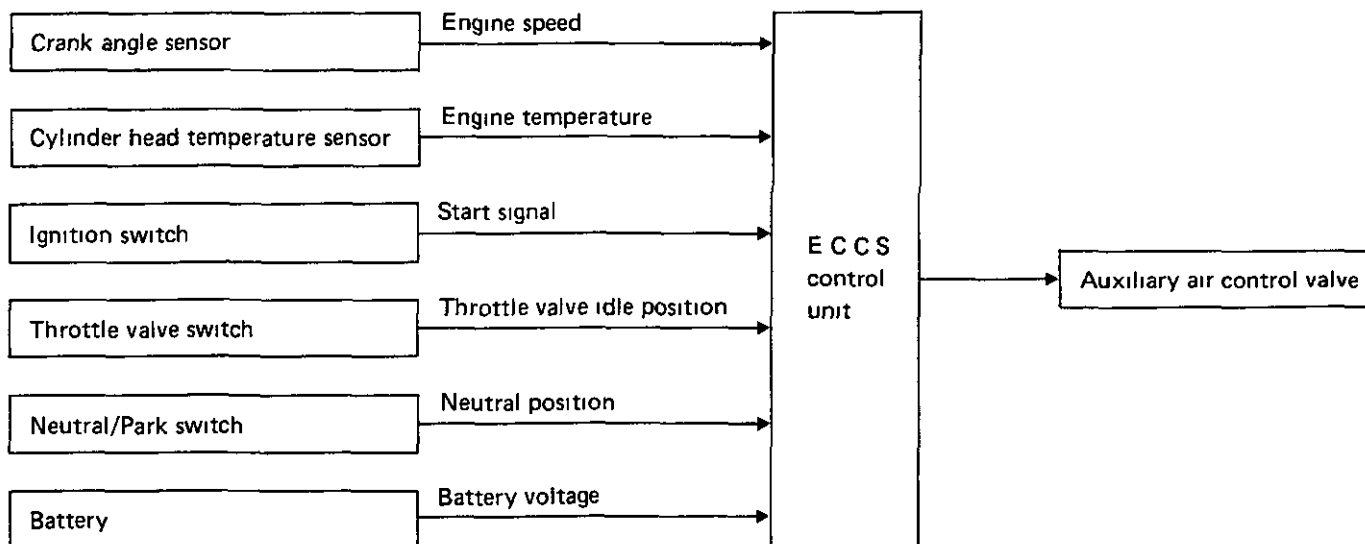

The idle speed is controlled by the E.C.C.S. control unit, corresponding to the engine operating conditions. The E.C.C.S. control unit senses the engine condition and determines the best idle speed at each cylinder head temperature and gear position. The control unit then sends an electronic signal corresponding to the difference between the best idle speed and the actual idle speed to the A.A.C. valve.

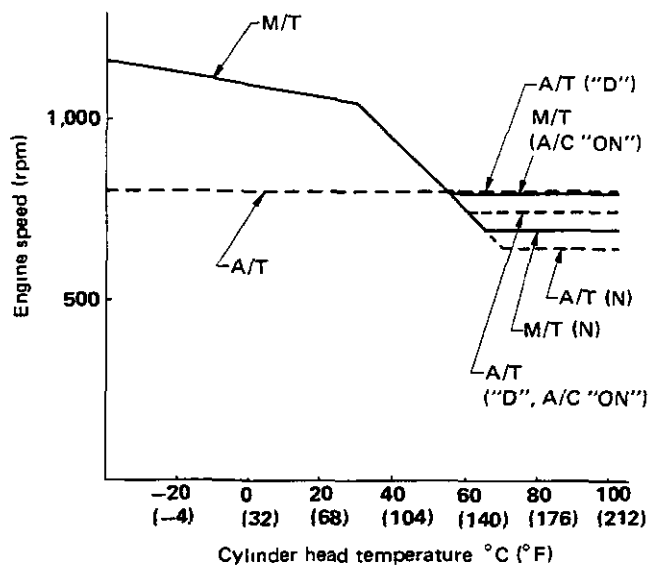

SEF641B

E.C.C.S. DESCRIPTION

Exhaust Gas Recirculation (E.G.R.) Control

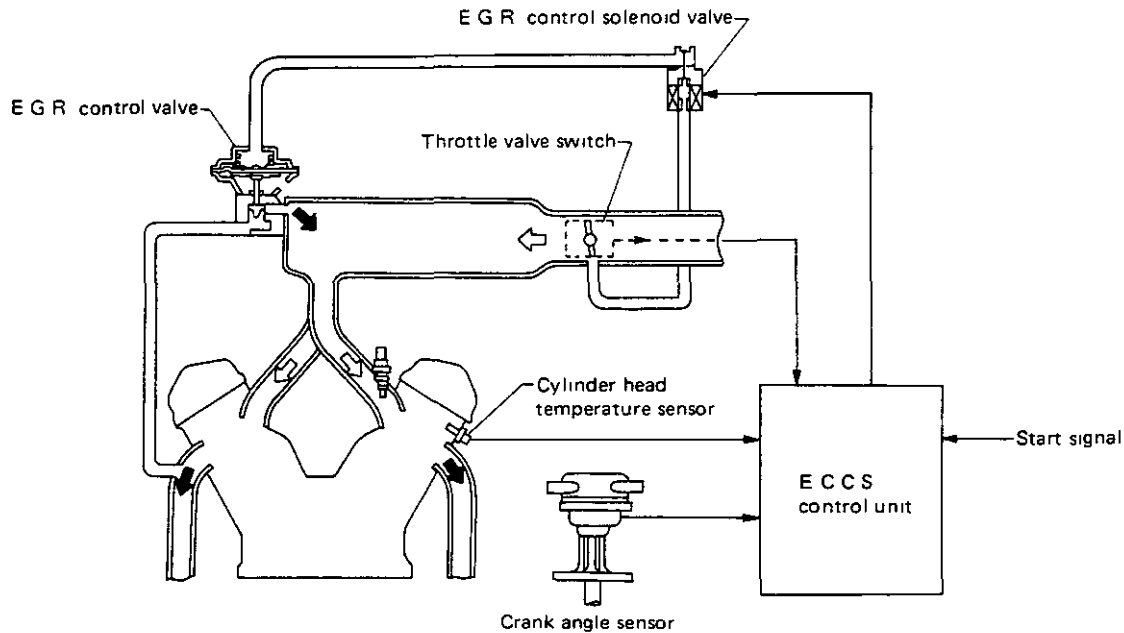
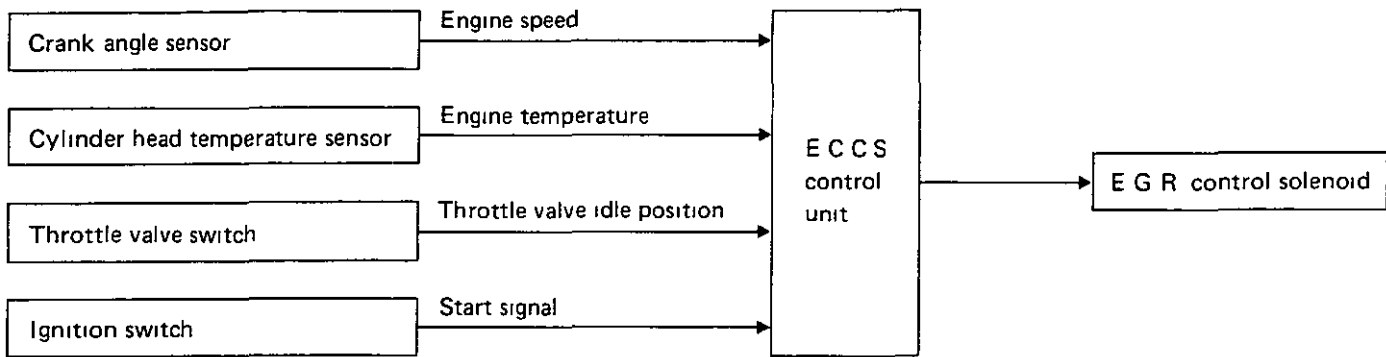

SEF642B

OPERATION

In the exhaust gas recirculation system, some of the exhaust gas is returned to the combustion chamber to lower the flame temperature during combustion. This results in a reduction of the nitrogen oxide density in the exhaust gas.

When the E.G.R. control valve is open, some of the exhaust gas is led from the exhaust manifold to the E.G.R. tube. The exhaust gas is then regulated by E.G.R. valve, and is introduced into the intake manifold.

The signal from the E.C.C.S. control unit is sent to the E.G.R. control solenoid valve, which cuts the vacuum line for the E.G.R. control valve when any of the following conditions are met

Operation

Condition	E.G.R. control solenoid	E.G.R. system
Engine starting Throttle valve switch "ON"	ON	Does not operate
Low engine temperature		
Engine speed below 900 rpm above 3,200 rpm	OFF	Operates
Except above		

E.C.C.S. DESCRIPTION

Fuel Pump Control

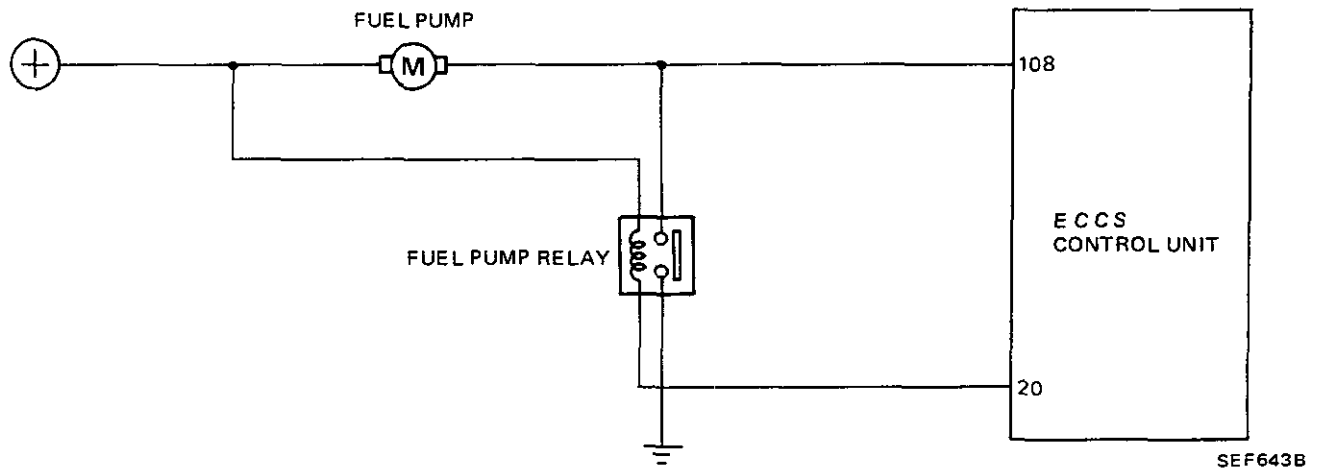
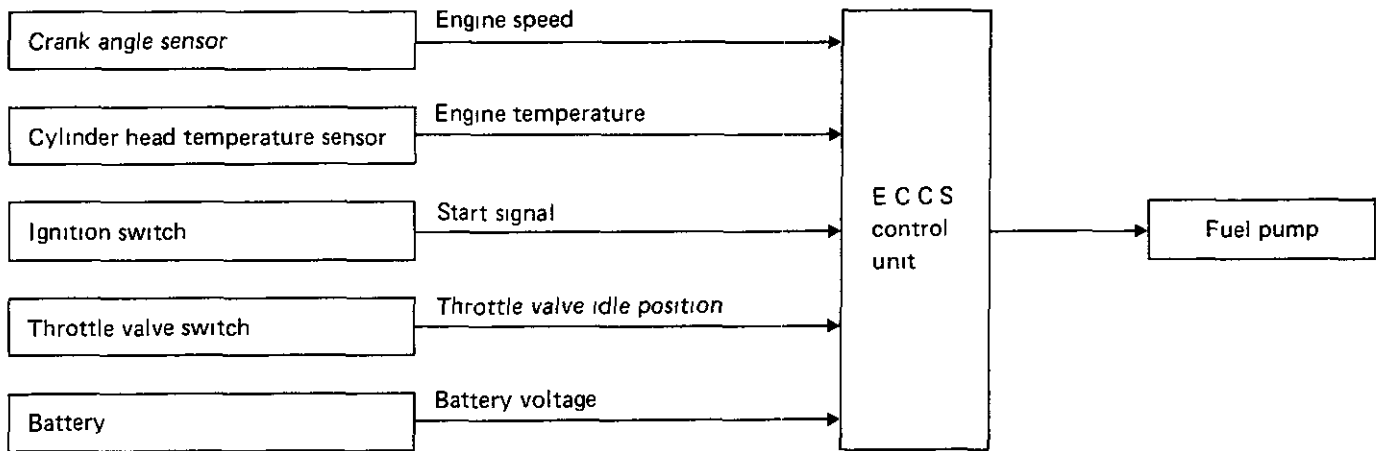

SEF643B

Fuel pump voltage control

The fuel pump is controlled by the E C C S control unit adjusting the voltage supplied to the fuel pump

Conditions	Voltage
5 seconds after ignition switch is turned to ON Engine cranking 25 5 seconds after engine start [above 50°C (122°F)] Engine temp above 90°C (194°F) Engine temp below 10°C (50°F)	Approximately 13.4 [V]
Except above	9.4 ~ 13.4 [V] *1, 10.1 ~ 13.4 [V] *2

*1 VG30E engine

*2 VG30ET engine

Fuel pump ON-OFF control

Ignition switch position	Engine condition	Fuel pump relay	Fuel pump operation
ON	Stopped	OFF	Operates for 5 seconds
	Starting	ON for 30 seconds	Operates
	Running	OFF	Operates
	After stall	OFF	Stops in 1 second

DIAGNOSTIC PROCEDURE

Caution

- a. Before connecting or disconnecting E C C S harness connector to or from any E C.C.S. unit, be sure to turn the ignition switch to the "OFF" position and disconnect the negative battery terminal
Otherwise, there may be damage to control unit
- b. Do not attempt to disassemble any E C C S component parts. To conduct electrical checks on these component parts, closely follow the steps outlined under "ELECTRONIC CONTROL SYSTEM INSPECTION" on pages EF & EC-43 through EF & EC-59.
- c. When conducting self-diagnosing, follow the steps outlined under "SELF-DIAGNOSIS" on pages EF & EC-35 through EF & EC-42 in order to obtain accurate diagnosing results
After self-diagnosing has been completed, erase the memory properly
- d. Always turn the diagnosis mode selector carefully using a screwdriver. If it is turned forcibly, it may be damaged, resulting in the inability to perform the self-diagnosing or to monitor the mixture ratio
- e. Before troubleshooting, ensure that all harness connectors are secure.

DIAGNOSTIC PROCEDURE

Driveability

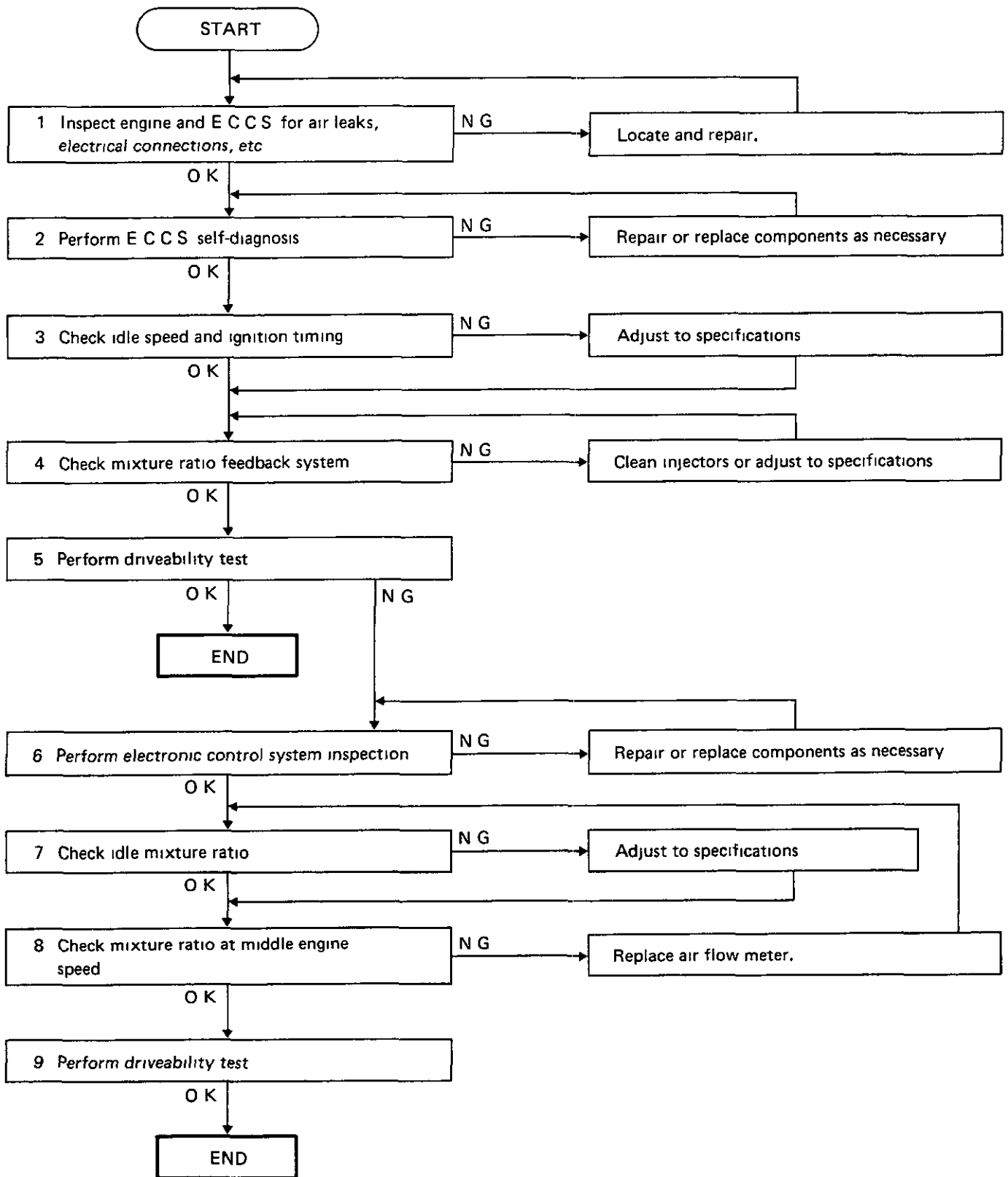

DIAGNOSTIC PROCEDURE

Driveability (Cont'd)

1. Inspect engine and E C C S. for air leaks, proper electrical connections, etc
 - 1) Check all hoses and ducts for air leaks
 - 2) Check air cleaner for clogging
 - 3) Check harness connectors for proper connections
 - 4) Check ignition wiring
 - 5) Check gaskets for leaks at all air intake components
 - 6) Check E G R valve operation
 - 7) Check air regulator operation
- 2 Perform E C C S self-diagnosis
Follow the procedure in E C C S SELF-DIAGNOSIS (Page EF & EC-35)
- 3 Check idle speed and ignition timing

a. Prepare the following conditions:

- Headlamp switch: OFF
- Heater blower: OFF
- Air conditioner switch: OFF
- Front wheel (Power steering model):
KEEP STRAIGHT AHEAD

b. Warm engine to operating temperature.

Check and adjust as follows

[VG30E engine (Without turbocharger)]

- 1) Stop engine and disconnect idle-up solenoid valve harness connector

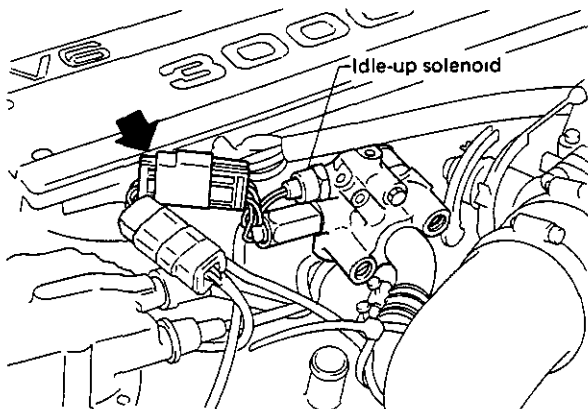

SEF644B

- 2) Start engine and race engine two or three times under no-load, then run engine at idle speed

- 3) Check idle speed

M/T & A/T (in "D" position)

700±50 rpm at sea level

650±50 rpm at high altitude condition

If necessary, adjust to the specified speed by turning idle speed adjusting screw

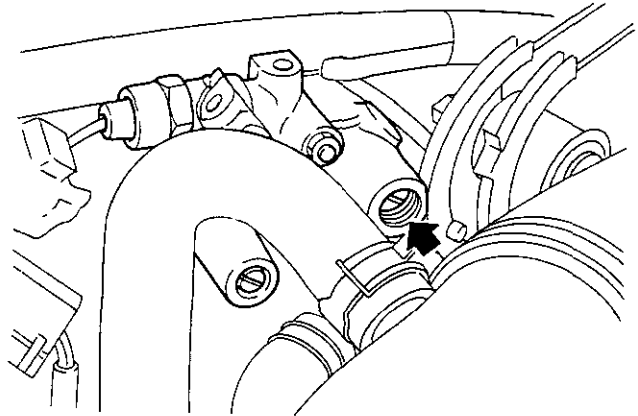

SEF645B

- 4) Stop engine and connect idle-up solenoid valve harness connector
- 5) Start engine and check ignition timing with a timing light

20°±2° B.T.D.C.

If necessary, adjust ignition timing by turning distributor

[VG30ET engine (With turbocharger)]

- 1) Race engine two or three times under no-load, then run engine at idle speed
- 2) Check idle speed.

M/T: 700±50 rpm

A/T: 650±50 rpm (in "D" position)

DIAGNOSTIC PROCEDURE

Driveability (Cont'd)

If out of specification, adjust as follows

- a Stop engine and disconnect A A C valve harness connector

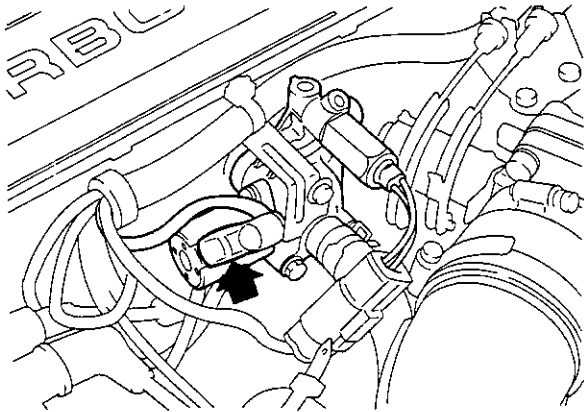

SEF646B

- b Start engine and adjust engine speed by turning idle speed adjusting screw

M/T: 650 rpm

A/T: 600 rpm (in "D" position)

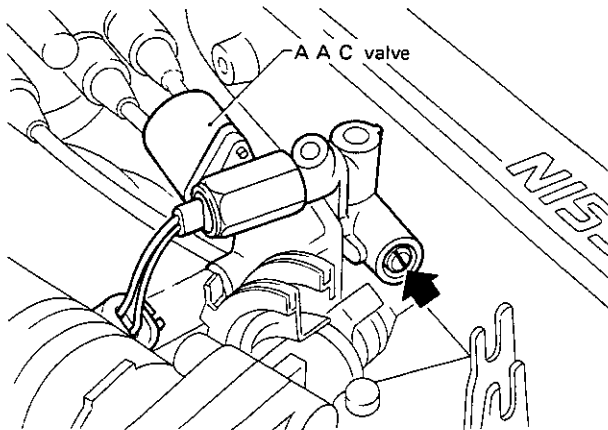

SEF647B

- c. Stop engine and connect A.A.C. valve harness connector Then start engine
- d Make sure that idle speed is in the specified range.
- 3) Check ignition timing with a timing light
 $20^{\circ} \pm 2^{\circ}$ B.T.D.C.

If necessary, adjust ignition timing by turning distributor

- 4 Perform mixture ratio feedback system inspection
Follow the procedure in MIXTURE RATIO

FEEDBACK SYSTEM INSPECTION (Page EF & EC-60)

- 5 Perform driveability test
Evaluate effectiveness of adjustments by driving vehicle If unsatisfactory, proceed to step 6
- 6 Perform electronic control system inspection
Check the following using circuit tester
 - Injector circuits
 - Air regulator circuit
 - E G R control solenoid circuit
 - Exhaust gas sensor heater circuitFollow the procedure in ELECTRONIC CONTROL SYSTEM INSPECTION (Page EF & EC-43)
- 7 Check idle mixture ratio
 - 1) Warm up engine to operating temperature
 - 2) Turn off engine and disconnect throttle valve switch harness connector
 - 3) Verify that the diagnosis mode selector is turned fully counterclockwise
 - 4) Start engine and verify that engine is still at operating temperature.
 - 5) Race engine two or three times under no-load, then run engine at idle speed
 - 6) Look at inspection lamps (red and green)

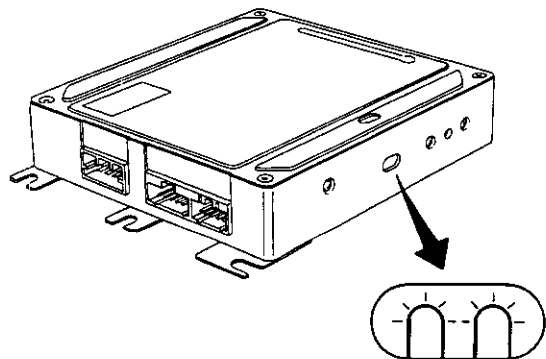

SEF648B

- When both inspection lamps blink, it indicates that the idle mixture ratio is correct.

DIAGNOSTIC PROCEDURE

Driveability (Cont'd)

- 7) If N.G., adjust idle mixture ratio by turning variable resistor on air flow meter so that inspection lamps blink simultaneously

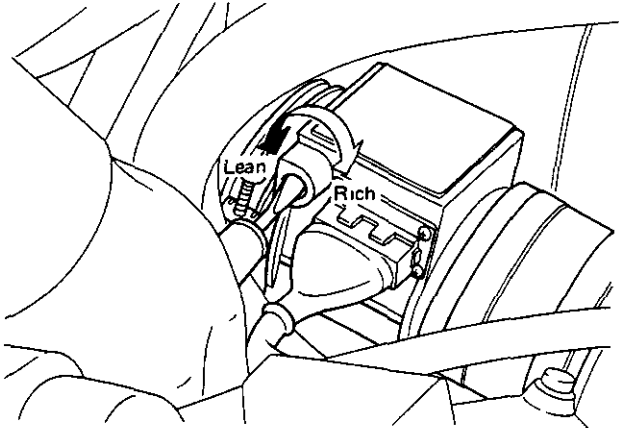

SEF649B

- 8 Check mixture ratio at middle engine speed
 - 1) Verify that inspection lamps on control unit blink simultaneously at idle.
 - 2) Race engine two or three times under no-load, then run engine at idle speed
 - 3) Gradually increase engine speed and check for operating (blinking) of the inspection lamps at different engine rpms (up to approximately 2,000 rpm).
 - If both inspection lamps continue to blink during idle to 2,000 rpm range, it indicates that the idle mixture ratio is correct
 - 4) If N.G., replace air flow meter and adjust idle mixture ratio as per step 7
 - 5) Turn off engine and connect throttle valve switch harness connector
9. Perform driveability test
Re-evaluate vehicle performance.

DIAGNOSTIC PROCEDURE

Improper Idling and Stall

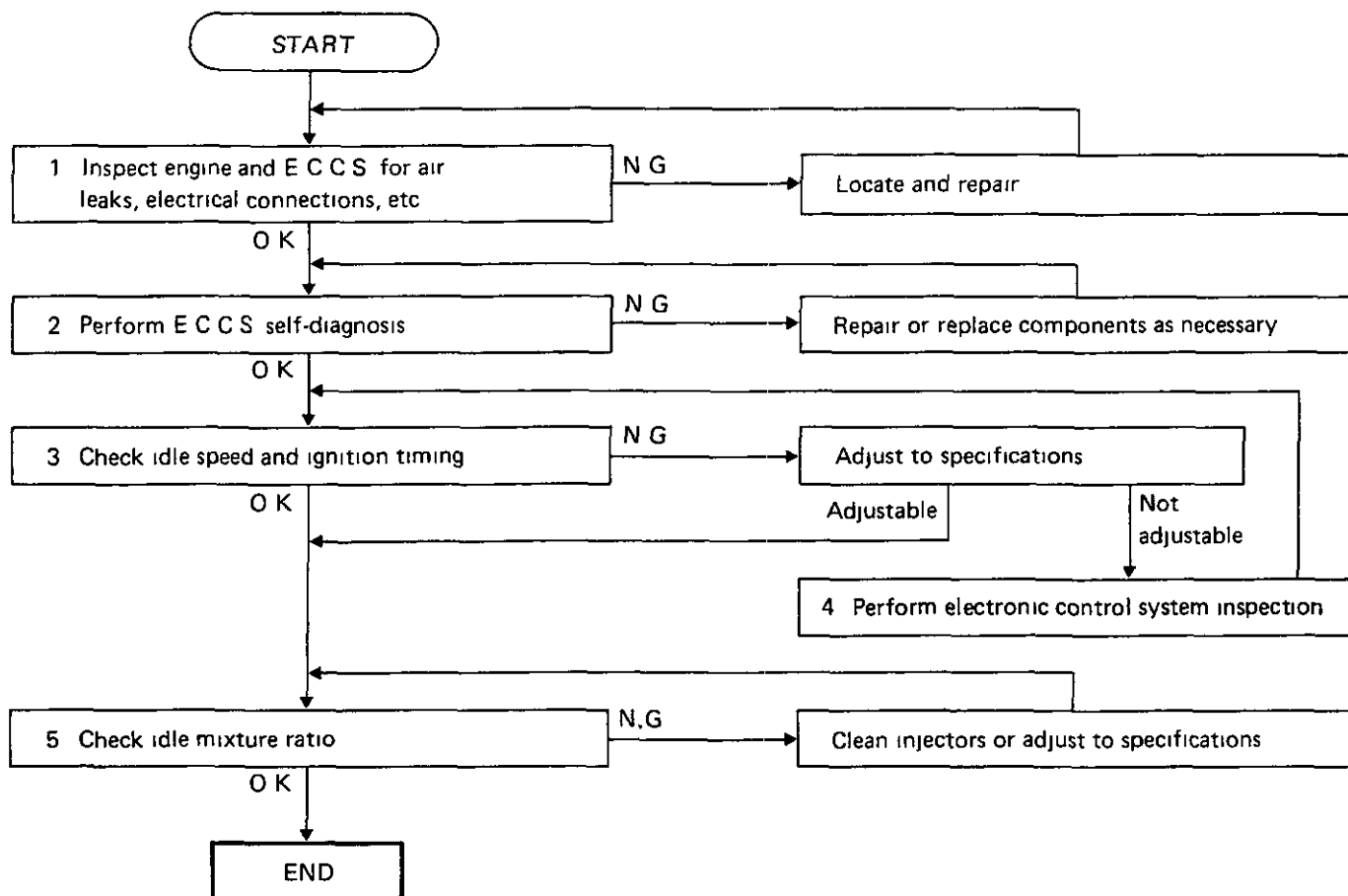

1. Inspect engine and E C C S for air leaks, electric connections, etc
Refer to DRIVEABILITY
2. Perform E C C S self-diagnosis
Follow the procedure in E.C.C.S. SELF-DIAGNOSIS (Page EF & EC-35).
3. Check idle speed and ignition timing.
Refer to DRIVEABILITY
4. Perform electronic control system inspection.
Check the following using circuit tester
 - Injector circuit
 - Air regulator circuit
 - Idle-up solenoid valve (Without turbocharger)
 - A.A.C. valve (With turbocharger)
 - E G R. control solenoid circuitFollow the procedure in ELECTRONIC CONTROL SYSTEM INSPECTION (Page EF & EC-43)
5. Check idle mixture ratio.
Refer to DRIVEABILITY

DIAGNOSTIC PROCEDURE

Engine Startability

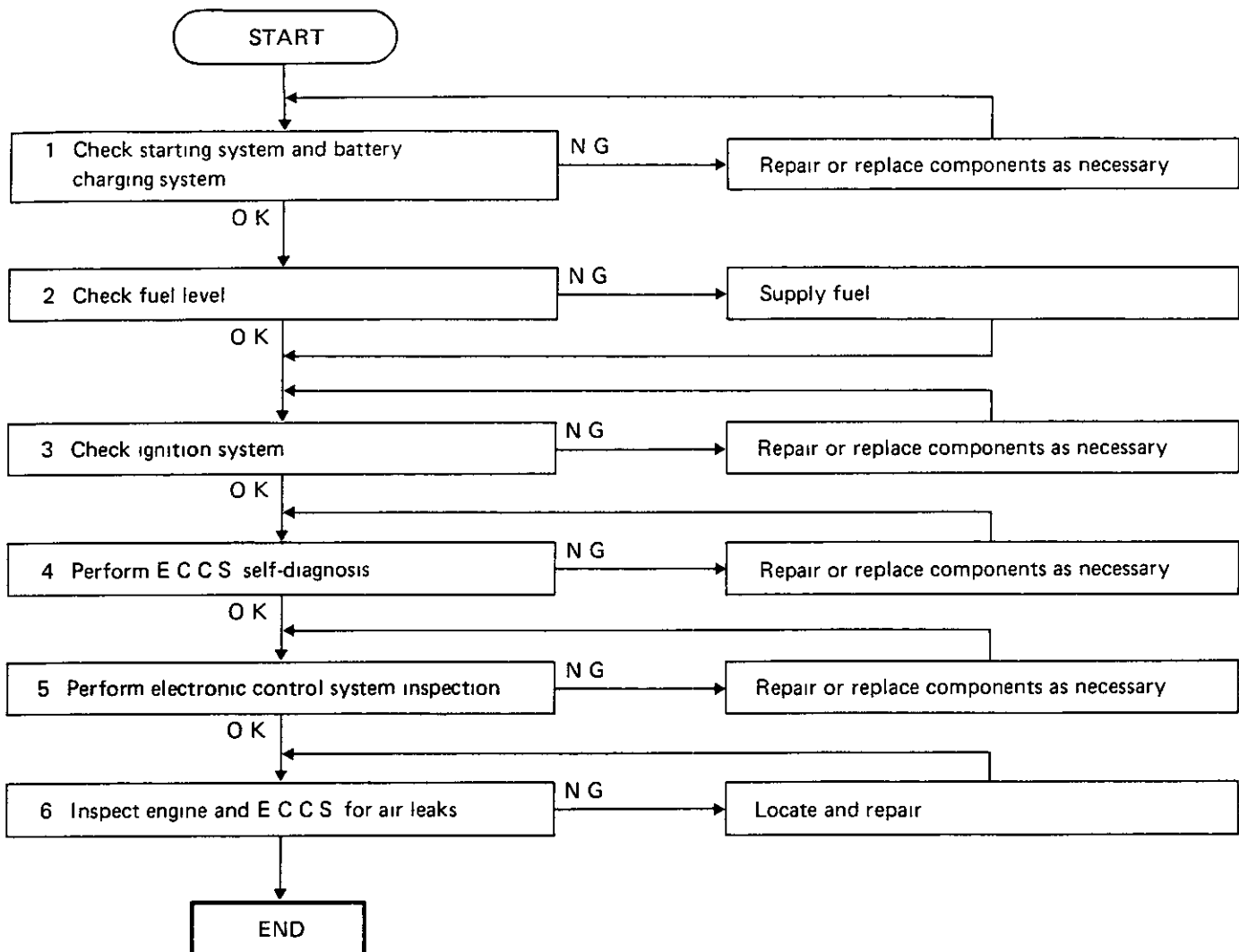

1. Check starting system and battery charging system

1) Check starter operation

2) Check battery voltage.
Repair or replace as necessary.

2. Check fuel level

If fuel level is low or empty, add fuel

3. Check ignition system.

1) Check ignition wiring

2) Check distributor rotor head

3) Check spark plug

4. Perform E C C.S. self-diagnosis. Follow the procedure in E.C.C.S. SELF-DIAGNOSIS (page EF & EC-35)

5. Perform electronic control system inspection.
Check the following using circuit tester.

- Injector circuit

- Air regulator circuit

- E G.R control solenoid valve

Follow the procedure in ELECTRONIC CONTROL SYSTEM INSPECTION (page EF & EC-43)

6. Inspect engine and E C C S for air leaks

Refer to DRIVEABILITY

SELF-DIAGNOSIS

Self-diagnostic System

The self-diagnostic system determines malfunctions of signal systems such as sensors, actuators, and wire harnesses based on the status of the input signals received by the E C C S control unit. A malfunction is displayed by both the red and green L E D s (Light Emitting Diodes).

Basically, self-diagnosis is always performed when the power is furnished to the E C C S control unit. The self-diagnosis results are retained in the memory chip of the E C C S control unit and are displayed only when the diagnosis mode selector (located on the side of the E C C S control unit) is turned fully clockwise.

The self-diagnostic system is provided with functions which display malfunctions being checked as well as those which are stored in the memory. In this sense, it is very effective in determining an "intermittent" malfunction. The results which is or was stored in the memory can be erased by following the steps specified.

A malfunctioning area is determined by the number of blinks of both the red and green L E D s. First, the red L E D blinks and the green follows. The red L E D refers to the tenth digit while the green one refers to the unit digit. For example, when the red L E D blinks three times and the green L E D blinks twice, this implies number "32". In this way, all problems are classified by code numbers.

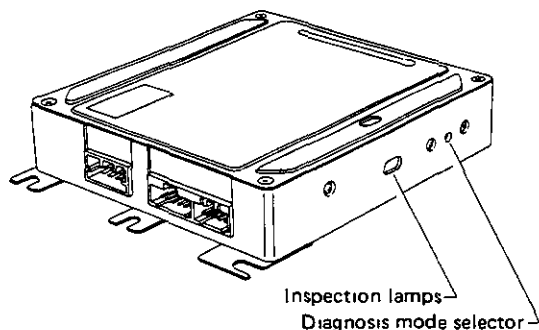

SEF650B

Judging the self-diagnosis results

- 1) When the ignition switch is turned "ON", the diagnostic system judges a malfunction

until the specified input signal is entered and detected as O K.

(These input signals are not stored in the memory.)

- 1) Vehicle speed sensor circuit (VG30ET engine)
When the vehicle speed exceeds 10 km/h (6 MPH) and its corresponding signal is entered.
- 2) Throttle valve switch (idle switch) circuit, neutral switch circuit (VG30ET engine) and air conditioner switch circuit
After the ignition switch is turned "ON" and "ON-OFF" signals from each switch are entered.
- 3) Start signal
After the engine has started and when start signals "ON" and then "OFF" are entered.
- 2) After the self-diagnostic system has detected a malfunction, it continues to provide a malfunction display until the memory is erased properly by the specified steps.
 - 1) Crank angle sensor circuit
 - When 1° or 120° signal is not entered after the engine has started.
 - When either 1° or 120° signal is not entered often enough.
 - 2) Air flow meter circuit
 - When the air flow meter produces an abnormally high output voltage with the engine off.
 - When the air flow meter produces an abnormally low output voltage with the engine running.
 - 3) Cylinder head temperature sensor circuit
When the circuit is shorted or open.
 - 4) Ignition signal
When an ignition signal is not produced on the primary winding of the ignition coil after the engine has started.
 - 5) Fuel pump circuit
When current flowing through the E C C S control unit to drive the fuel pump is too small or too large while the engine is operating.
 - 6) Detonation sensor circuit (VG30ET engine)
When the circuit is shorted with the engine operating at a speed of above 2,000 rpm.
 - 7) Fuel temperature sensor circuit
When the circuit is shorted or open.

SELF-DIAGNOSIS

—Self-diagnostic System (Cont'd)—

CAUTION.

- a. Always turn the diagnosis mode selector carefully using a screwdriver. Do not press hard to turn. Otherwise, the selector may be damaged.
- b. When the engine fails to start, crank the engine more than two seconds before starting the self-diagnosing.
- c. Before starting the self-diagnosing, do not erase the stored memory. Doing so will reduce the self-diagnosis function considerably.
- d. After a malfunctioning area has been corrected, be sure to erase the memory.
- e. The self-diagnosed results are retained in the memory by a small current flow from the battery. Disconnecting the battery cable or the E.C.C.S.'s 15-pin connector erases the memory stored. Always perform the self-diagnosing regarding "intermittent" checks before disconnecting.
- f. The crank angle sensor signal plays an important role in the E.C.C.S. A malfunctioning sensor is sometimes accompanied by a display which shows malfunctions in other signal systems. In such a case, always start with checking the crank angle sensor.

SELF-DIAGNOSIS

Self-diagnostic Procedure

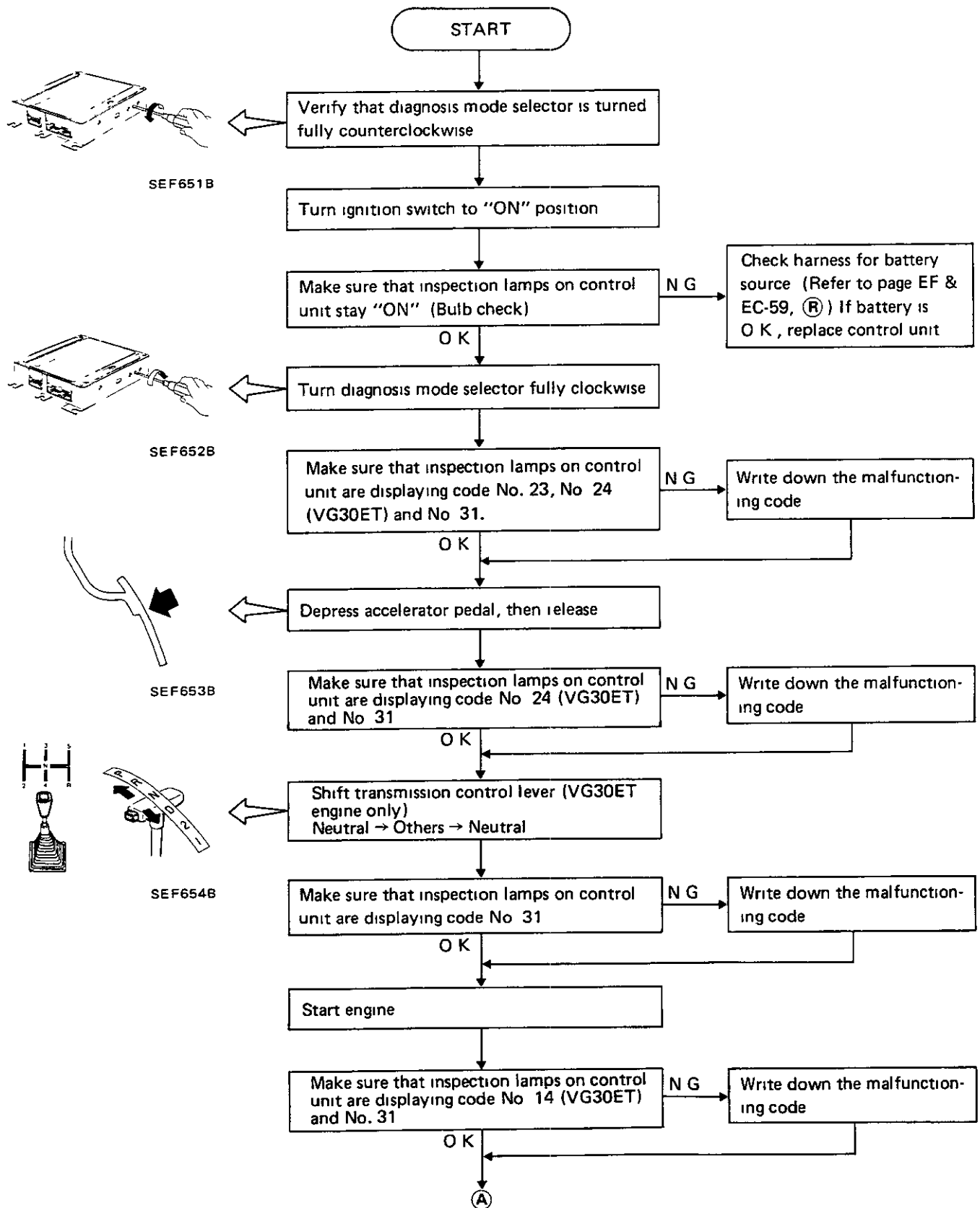

SELF-DIAGNOSIS

Self-diagnostic Procedure (Cont'd)

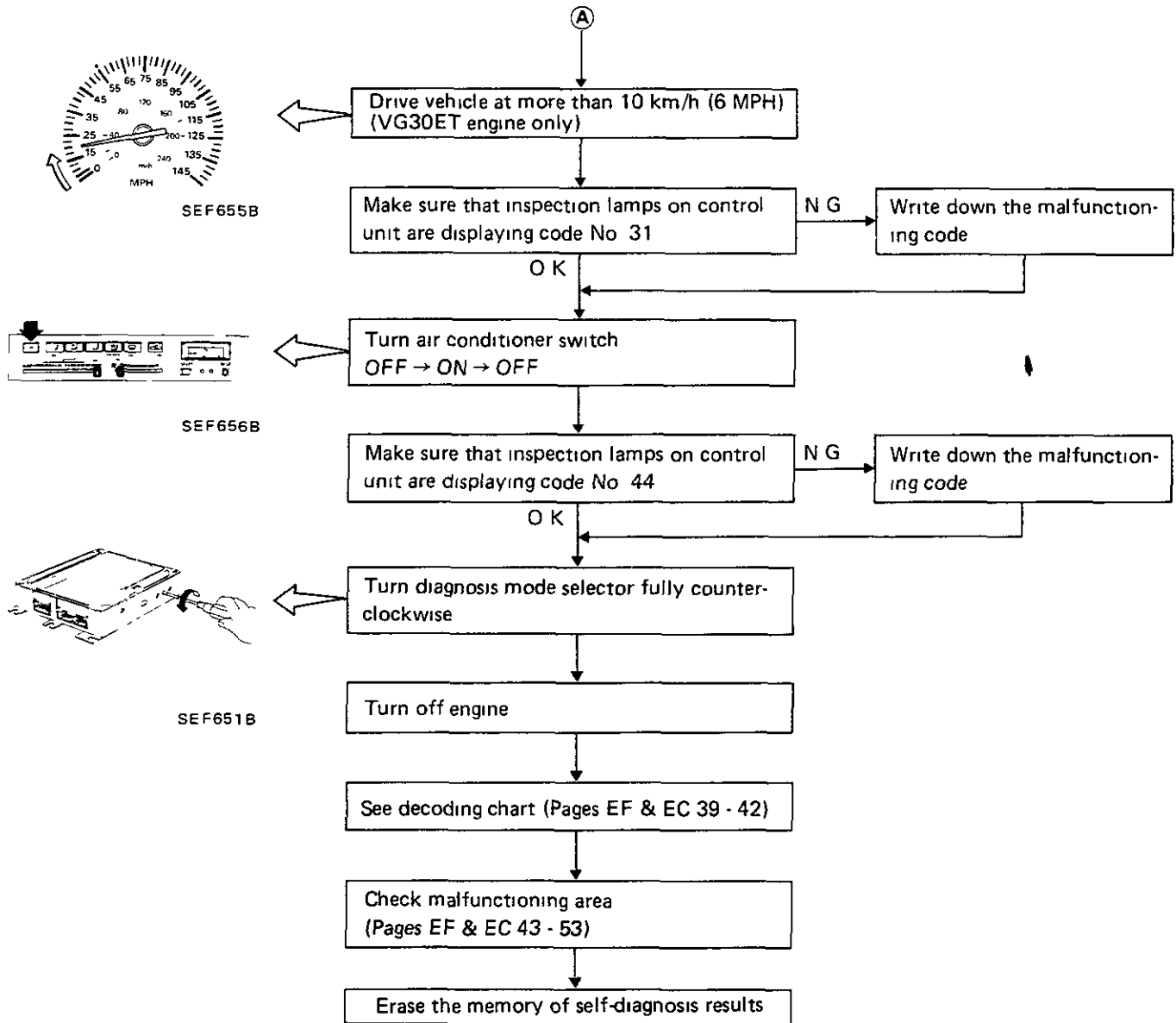

Procedure for memory erasure

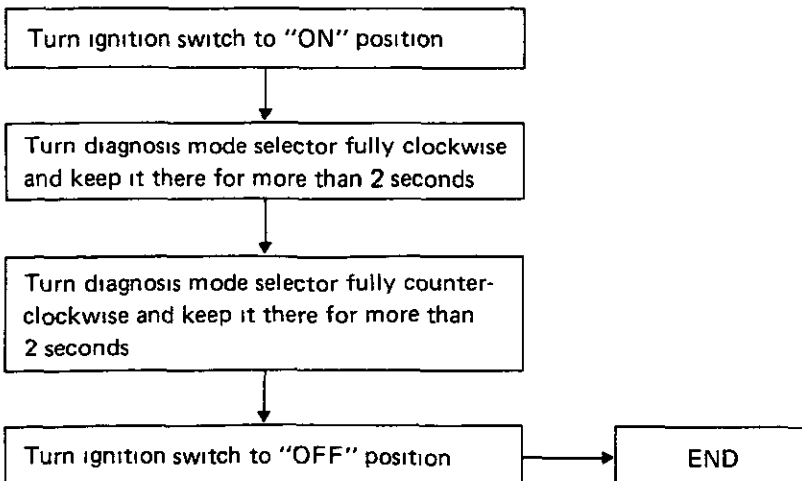

SELF-DIAGNOSIS

Decoding Chart

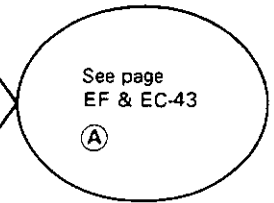
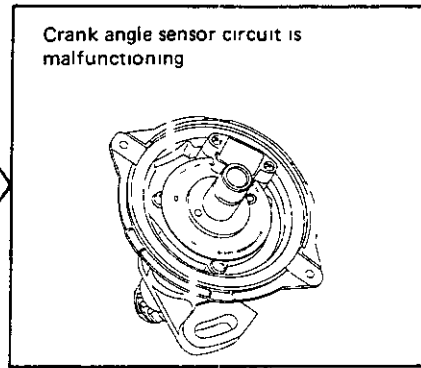
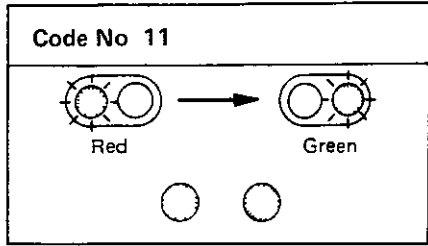

SEF657B

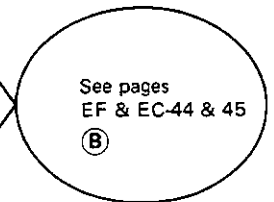
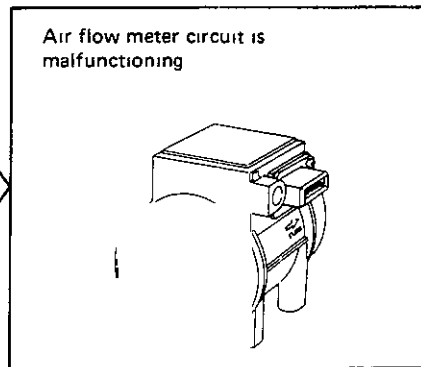
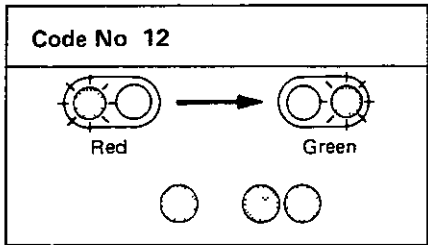

SEF658B

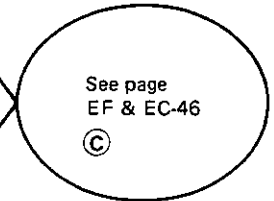
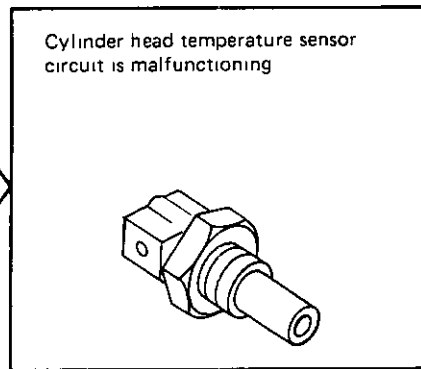
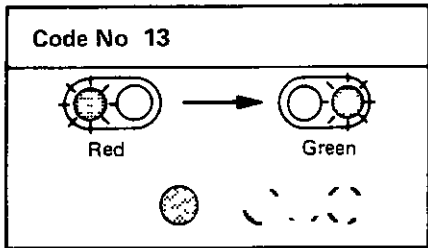

SEF659B

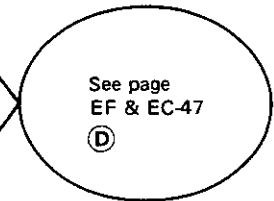
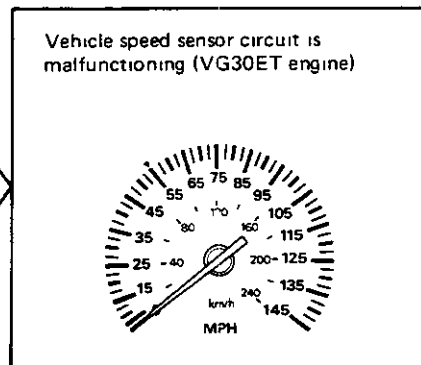
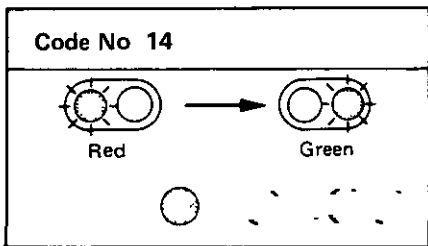

SEF660B

SELF-DIAGNOSIS

Decoding Chart (Cont'd)

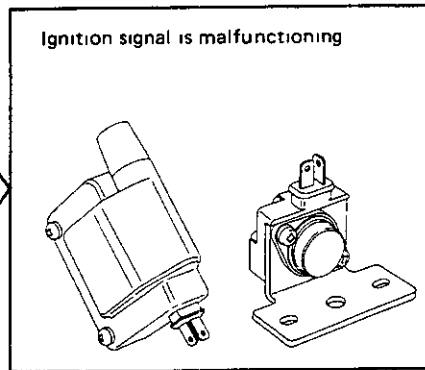
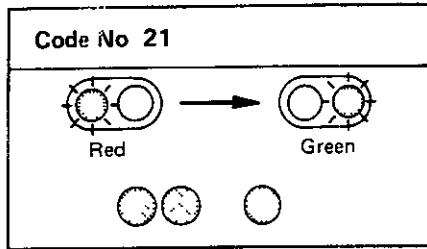

See page
EF & EC-48
(E)

SEF661B

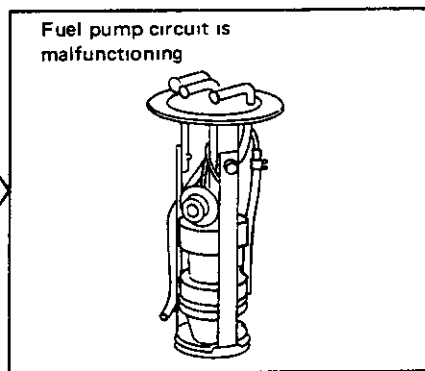
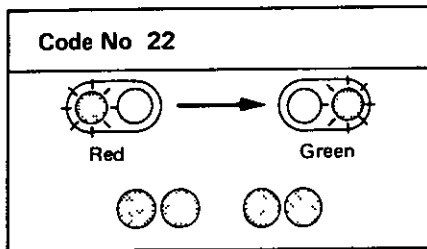

See page
EF & EC-49
(F)

SEF662B

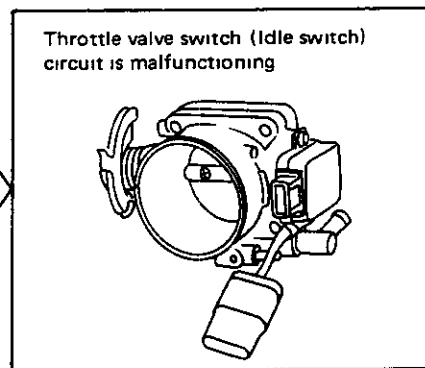
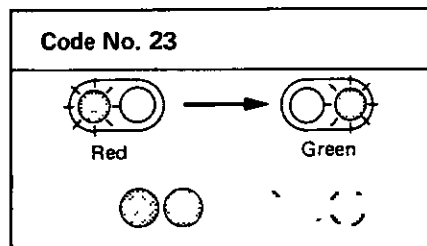

See page
EF & EC-50
(G)

SEF663B

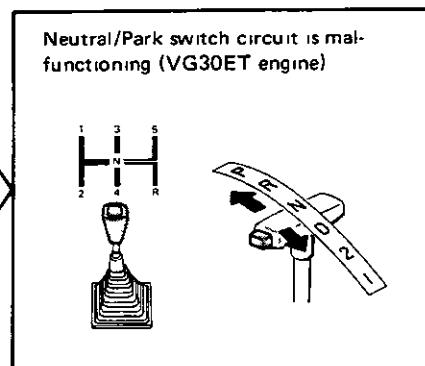
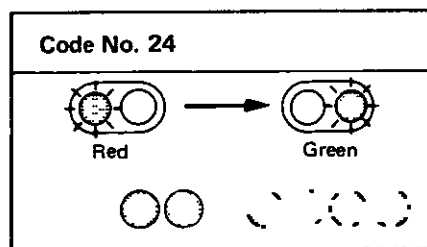

See page
EF & EC-51
(H)

SEF664B

SELF-DIAGNOSIS

Decoding Chart (Cont'd)

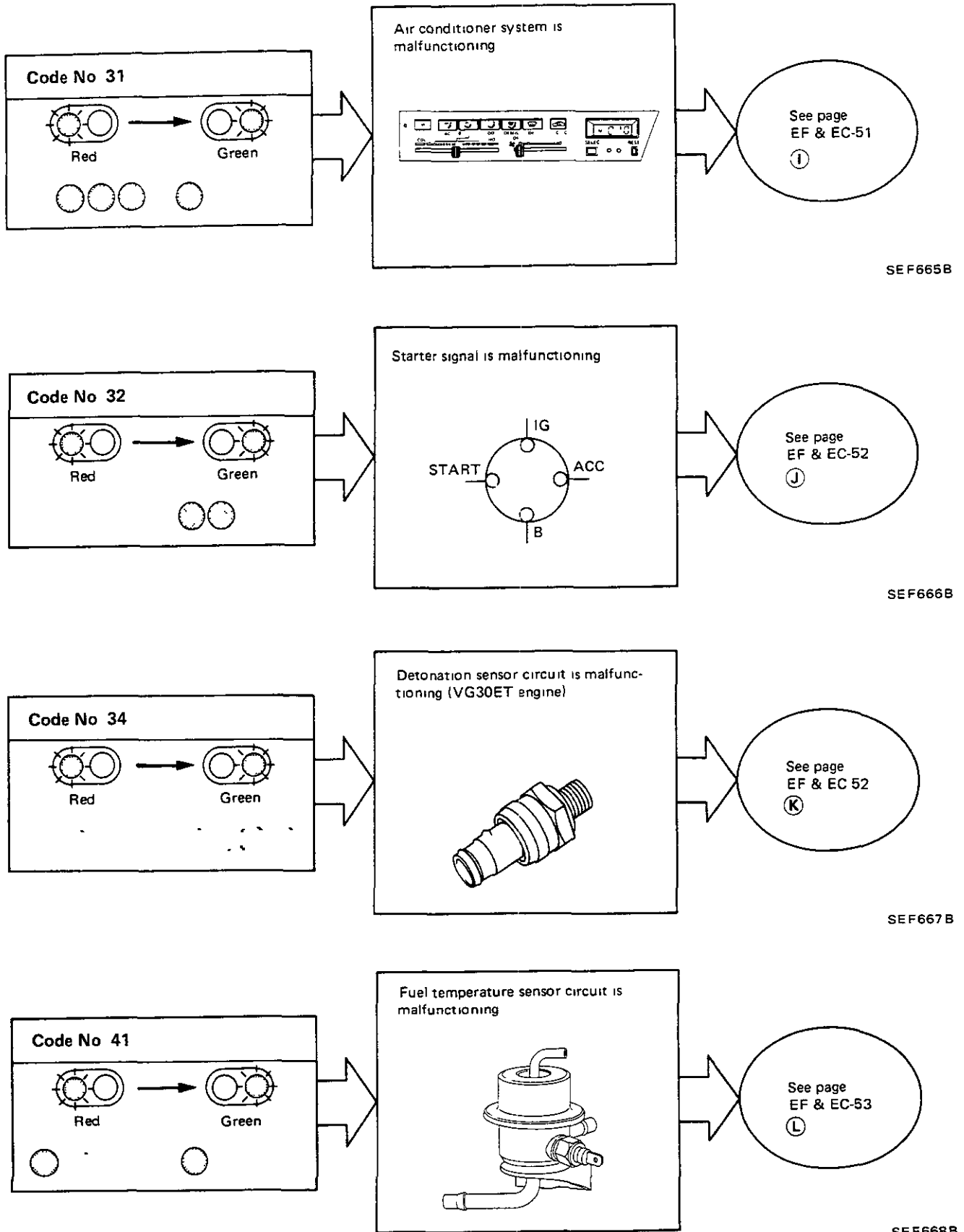

SEF665B

SEF666B

SEF667B

SEF668B

SELF-DIAGNOSIS

Decoding Chart (Cont'd)

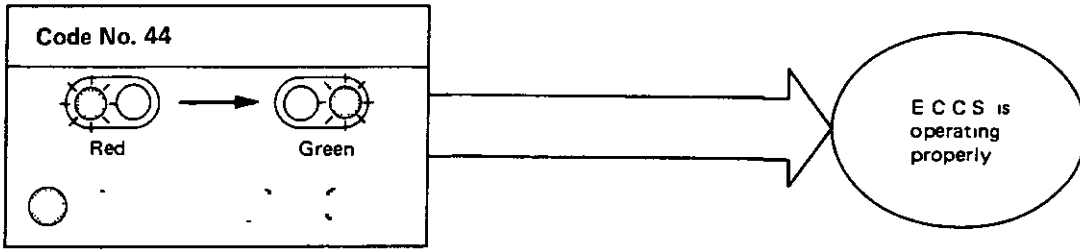

SEF669B

ELECTRONIC CONTROL SYSTEM INSPECTION

PREPARATION

Before checking the following items, ensure that each connector is securely connected

Ⓐ Crank angle sensor (Code No. 11)

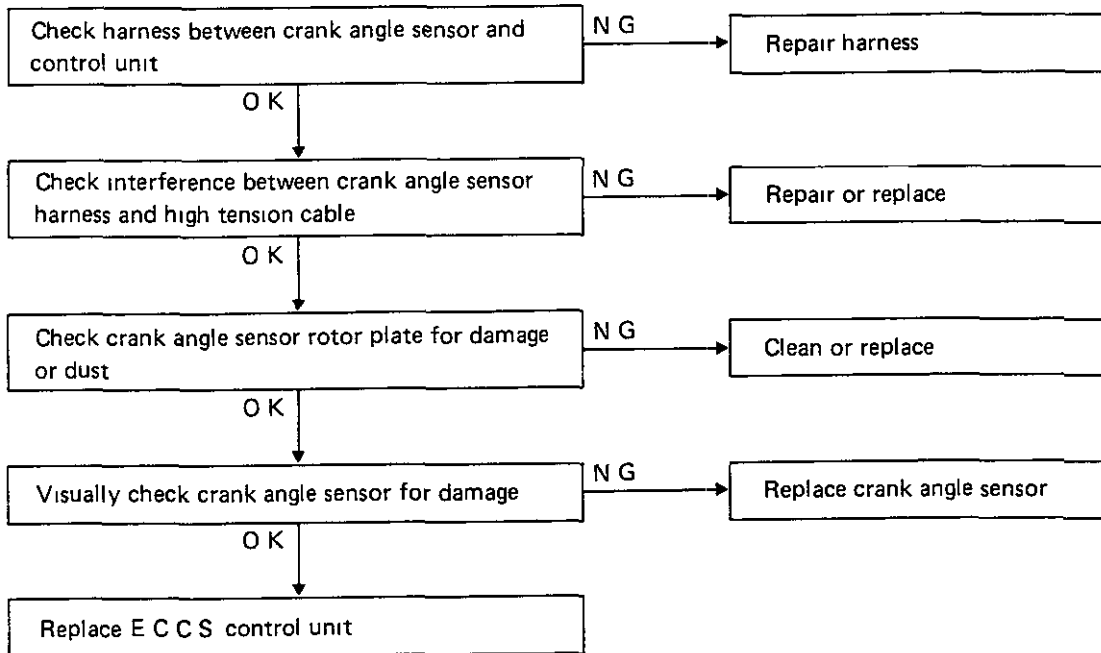

ELECTRONIC CONTROL SYSTEM INSPECTION

Ⓑ Air flow meter (Code No 12)

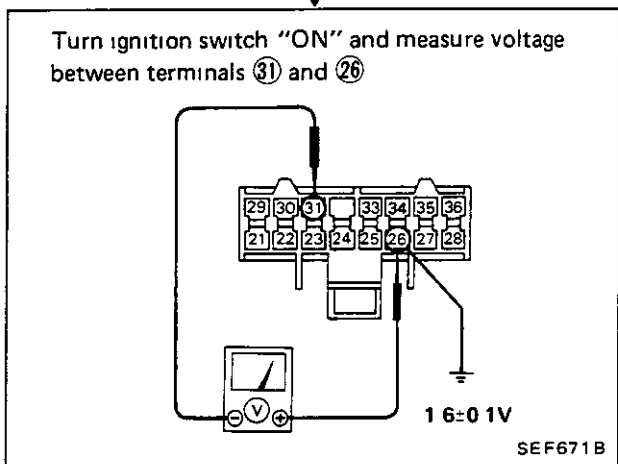
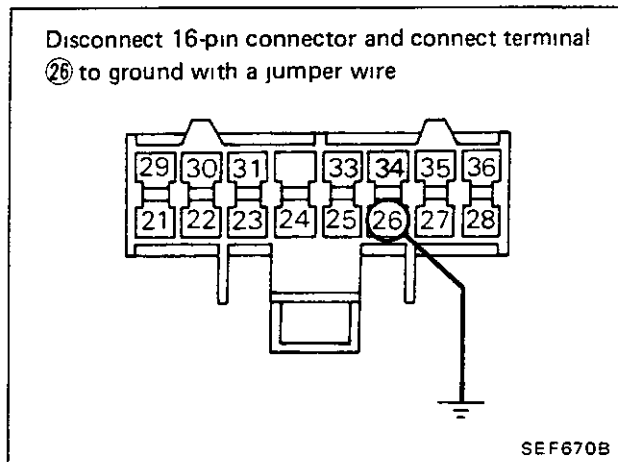

NG

Check harness for continuity

OK

NG

Repair harness

OK

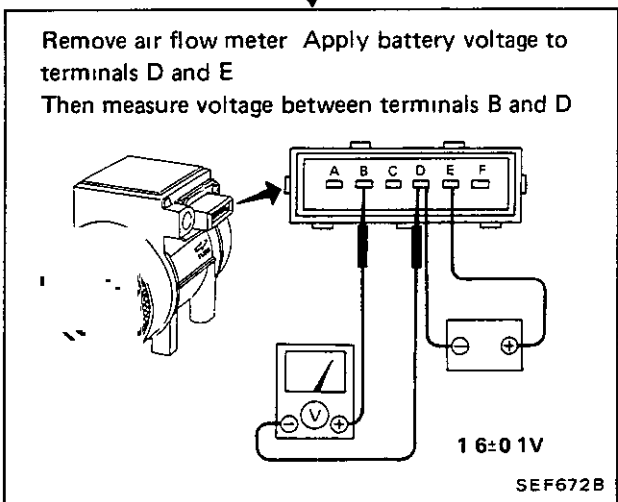

NG

Replace air flow meter

OK

Ⓐ

ELECTRONIC CONTROL SYSTEM INSPECTION

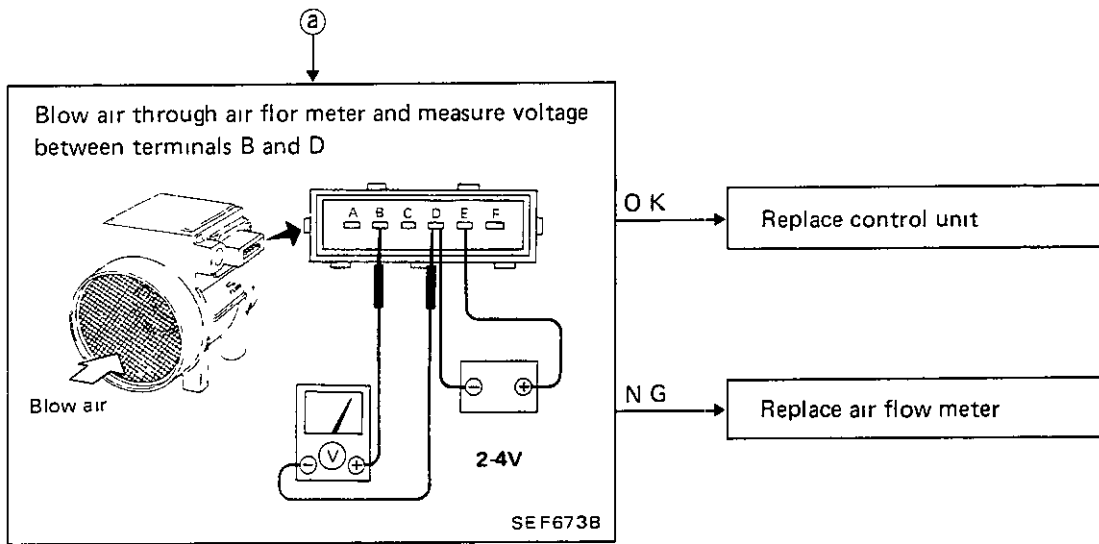

- Air flow meter self cleaning circuit

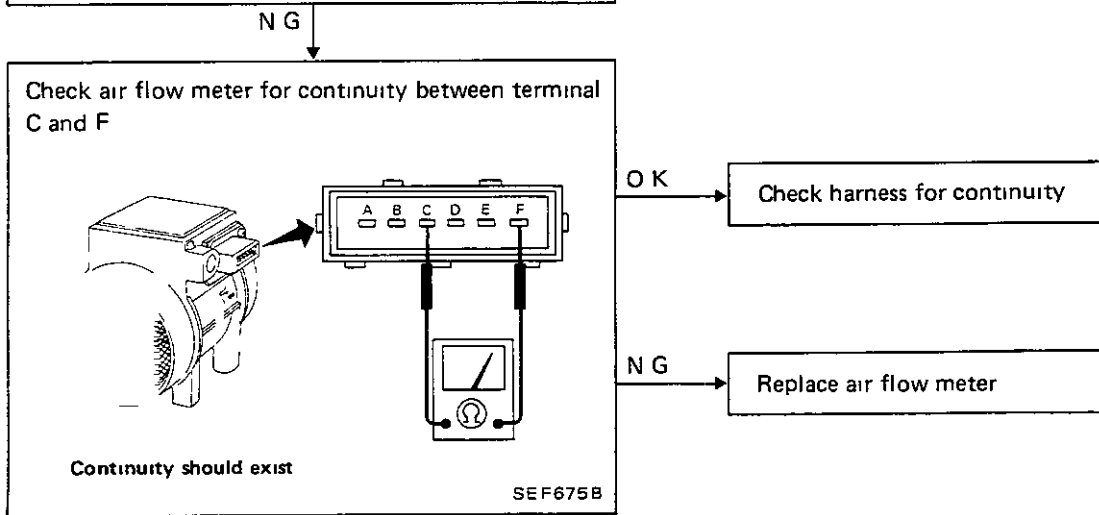
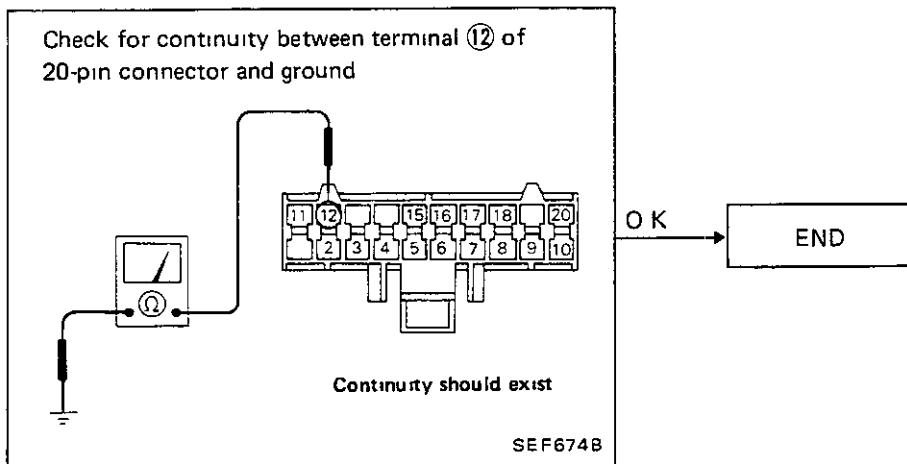

ELECTRONIC CONTROL SYSTEM INSPECTION

© Cylinder head temperature sensor (Code No 13)

Disconnect 16-pin connector and measure the resistance between terminals ②③ and ②⑥

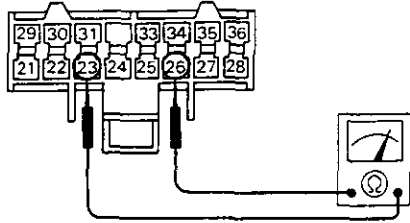

SEF676B

Cylinder head temperature	Resistance
Above 20°C (68°F)	Below 2.9 kΩ
Below 20°C (68°F)	Above 2.1 kΩ

OK

Replace control unit

NG

Check harness

NG

Repair harness

OK

Dip the sensor into water maintained at a temperature of 20°C (68°F), 80°C (176°F), etc., and read its resistance

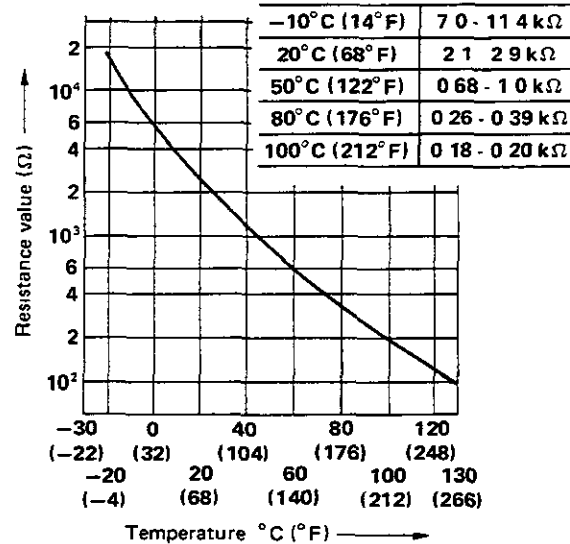
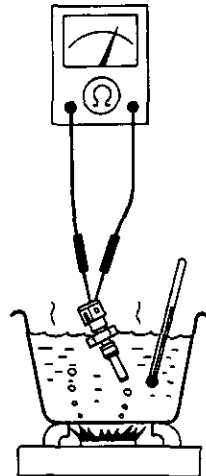

SEF677B

OK

NG

Replace cylinder head temperature sensor

ELECTRONIC CONTROL SYSTEM INSPECTION

④ Vehicle speed sensor (Code No. 14)

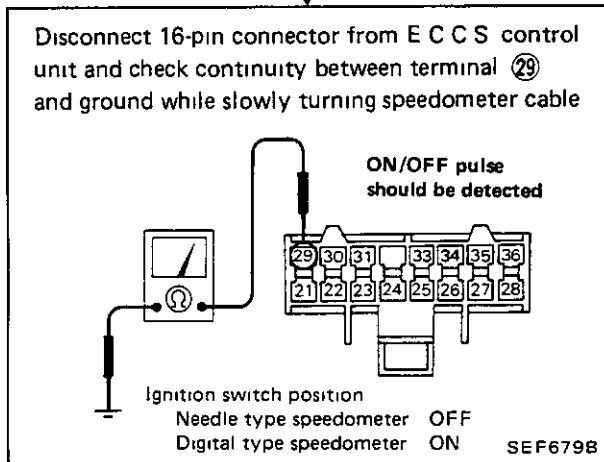
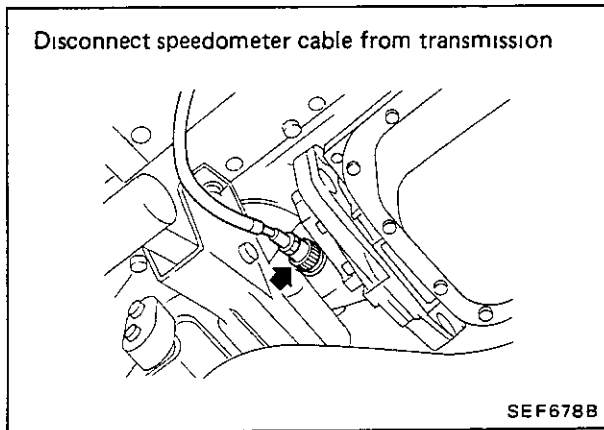

N G

Check harness and vehicle speed sensor
(Refer to "METER AND GAUGES" in
EL section)

O K

Replace E C C S control unit

ELECTRONIC CONTROL SYSTEM INSPECTION

⑤ Ignition signal (Code No 21)

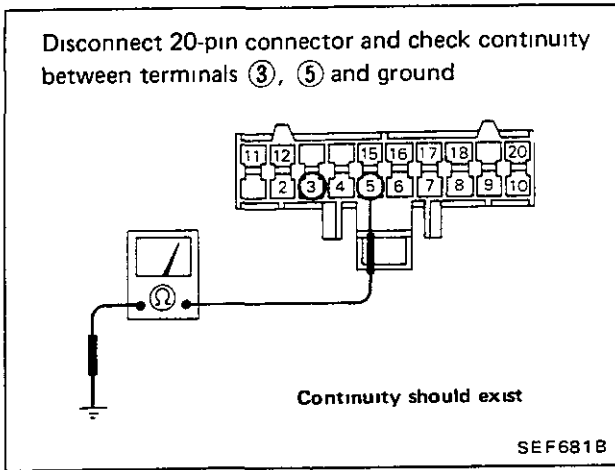

N G

Check harness, and repair as necessary

O K

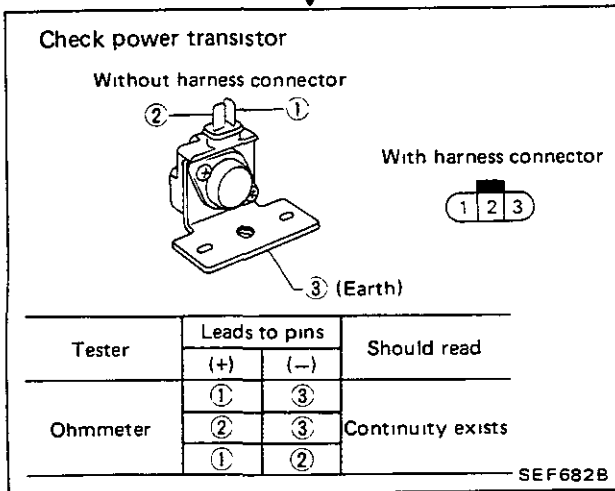

N G

Replace power transistor

O K

Replace E C C S control unit

ELECTRONIC CONTROL SYSTEM INSPECTION

F Fuel pump (Code No. 22)

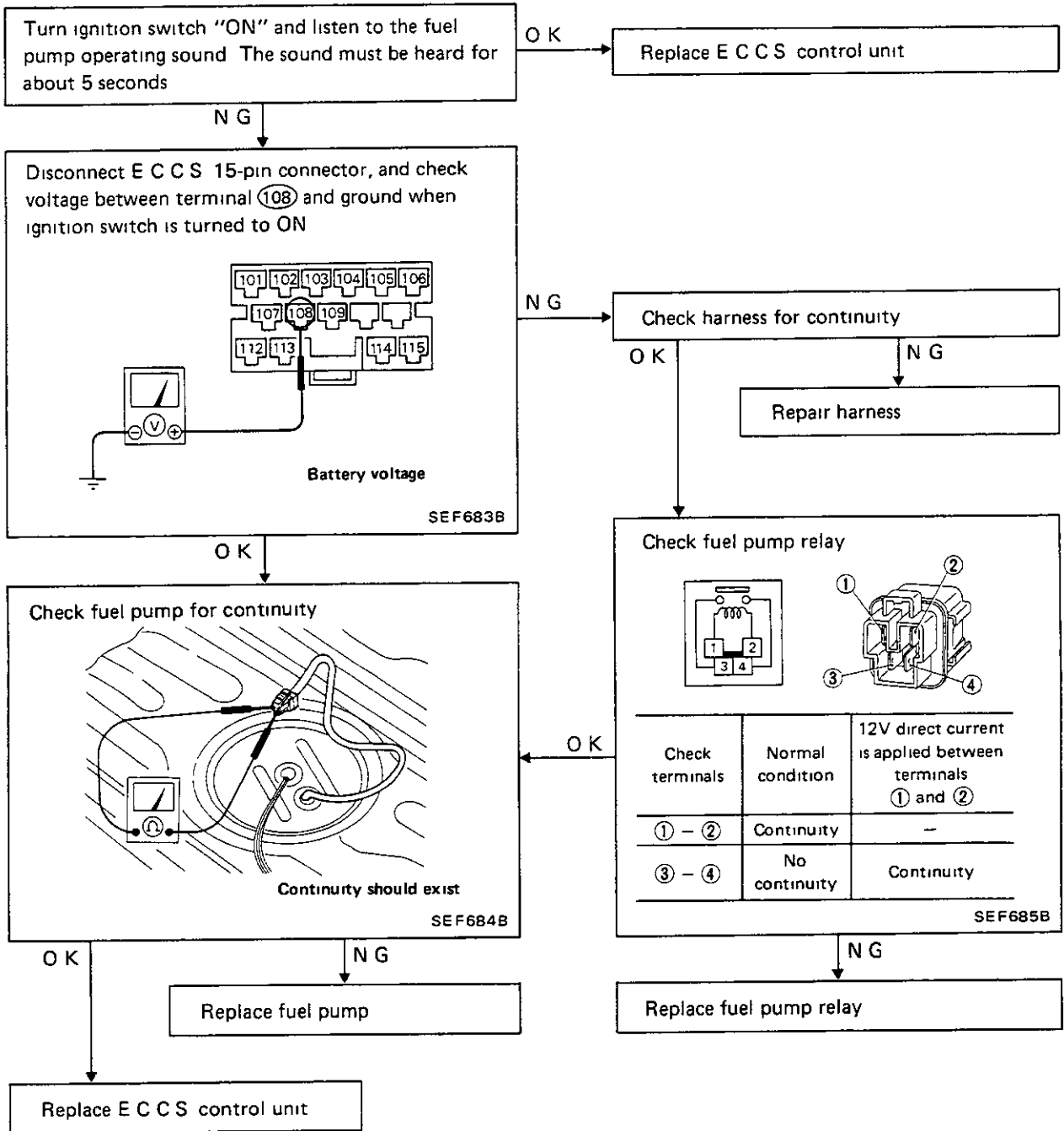

ELECTRONIC CONTROL SYSTEM INSPECTION

⑥ Throttle valve switch (Code No. 23)

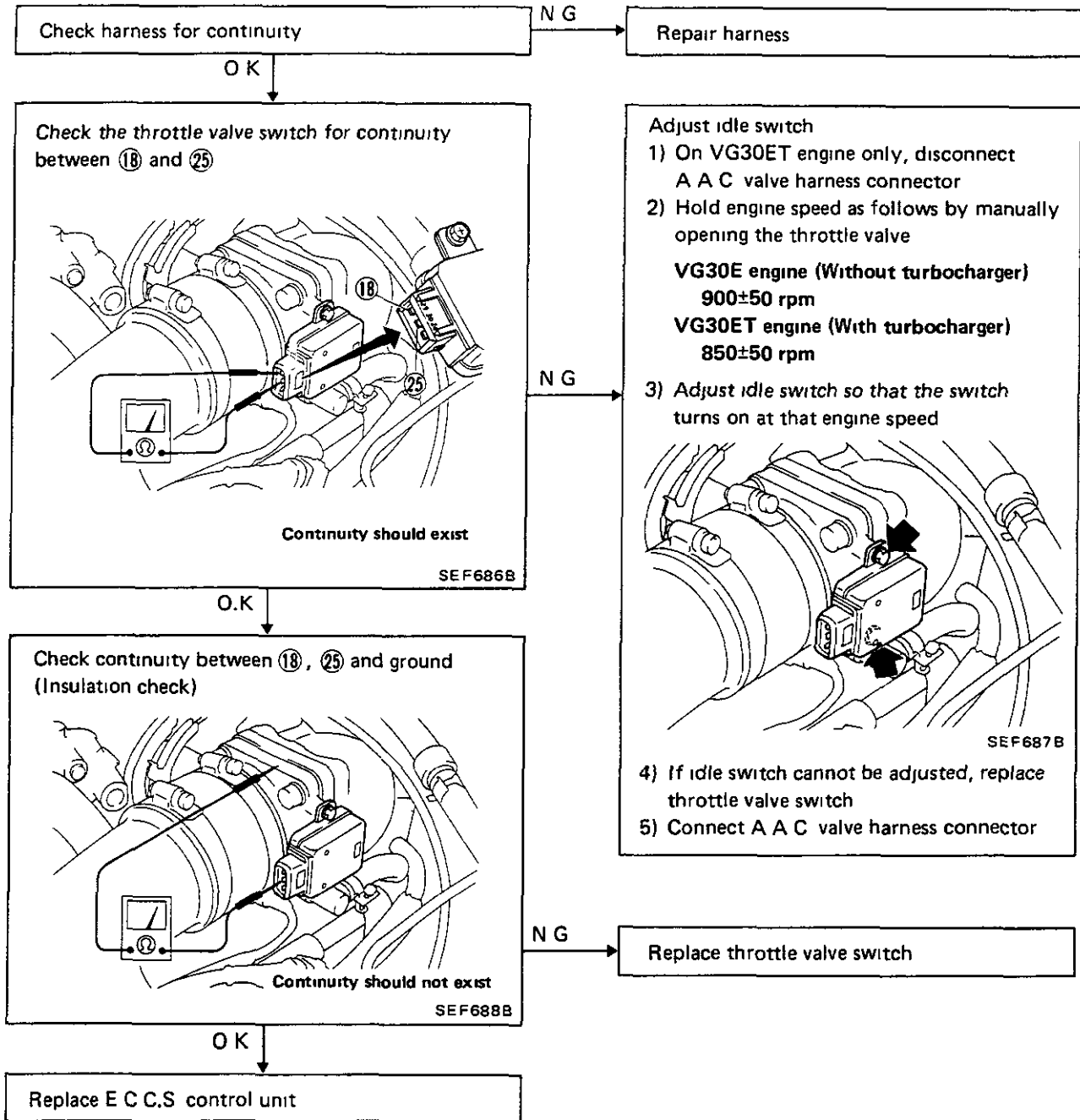

ELECTRONIC CONTROL SYSTEM INSPECTION

⑧ Neutral/Park switch (Code No. 24)

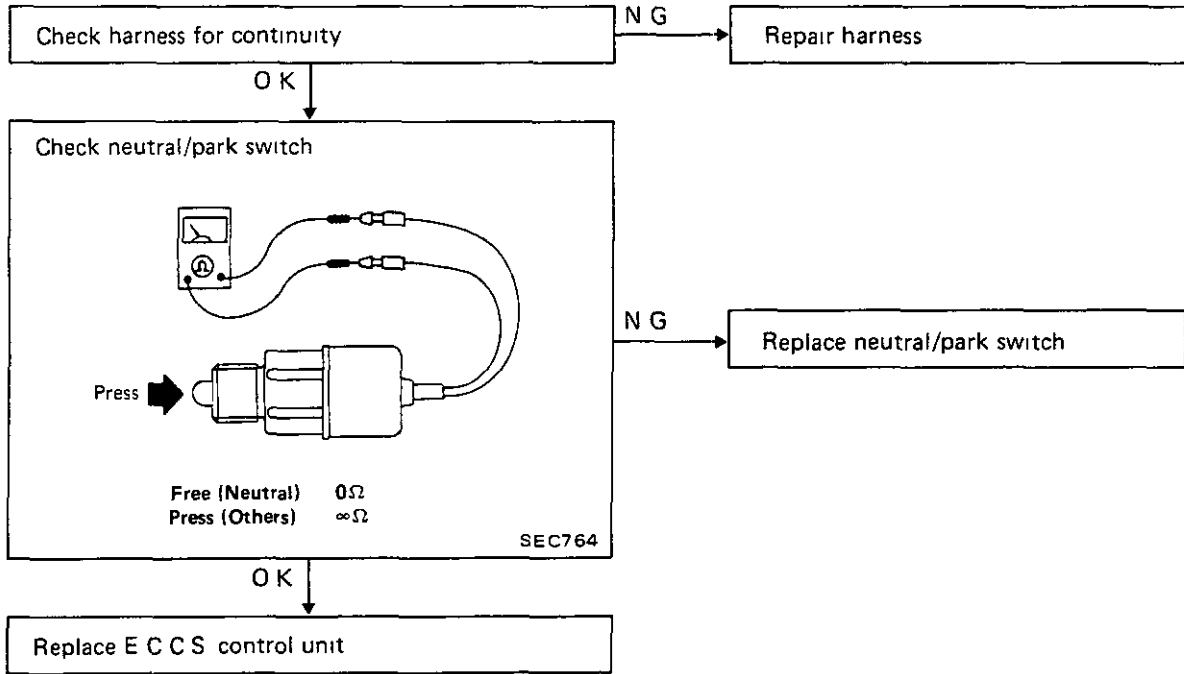

① Air conditioner (Code No. 31)

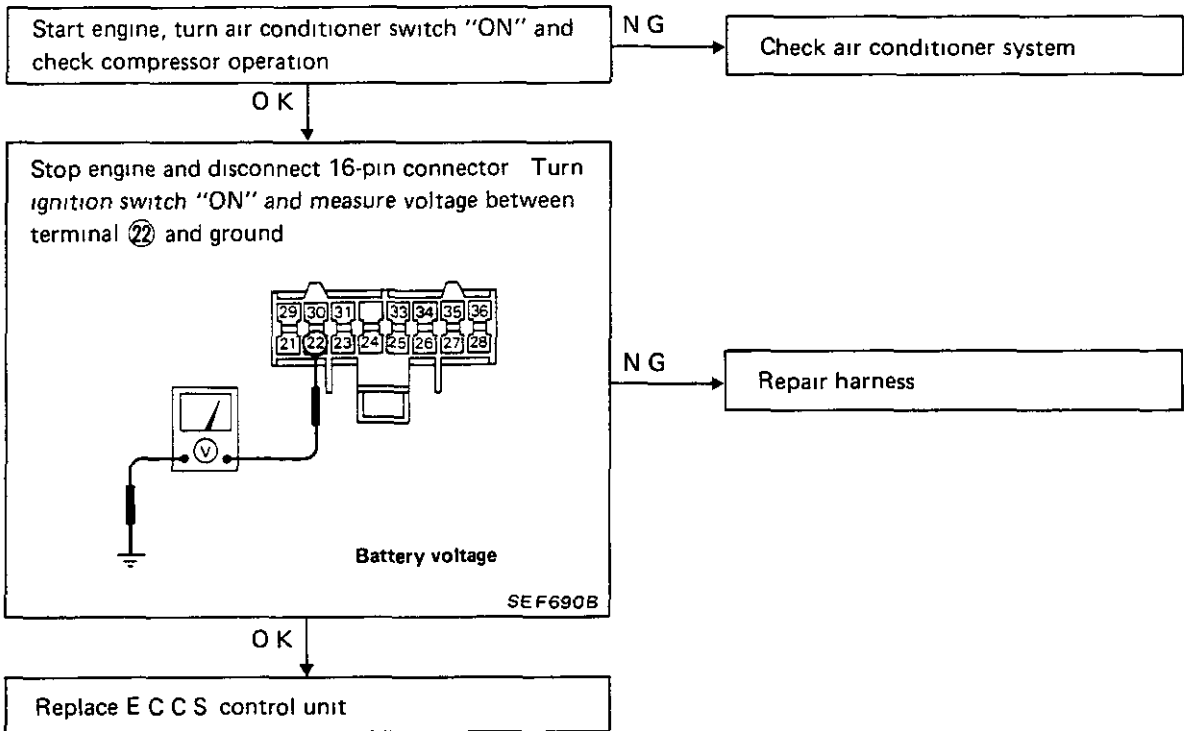

ELECTRONIC CONTROL SYSTEM INSPECTION

ⓐ Start signal (Code No. 32)

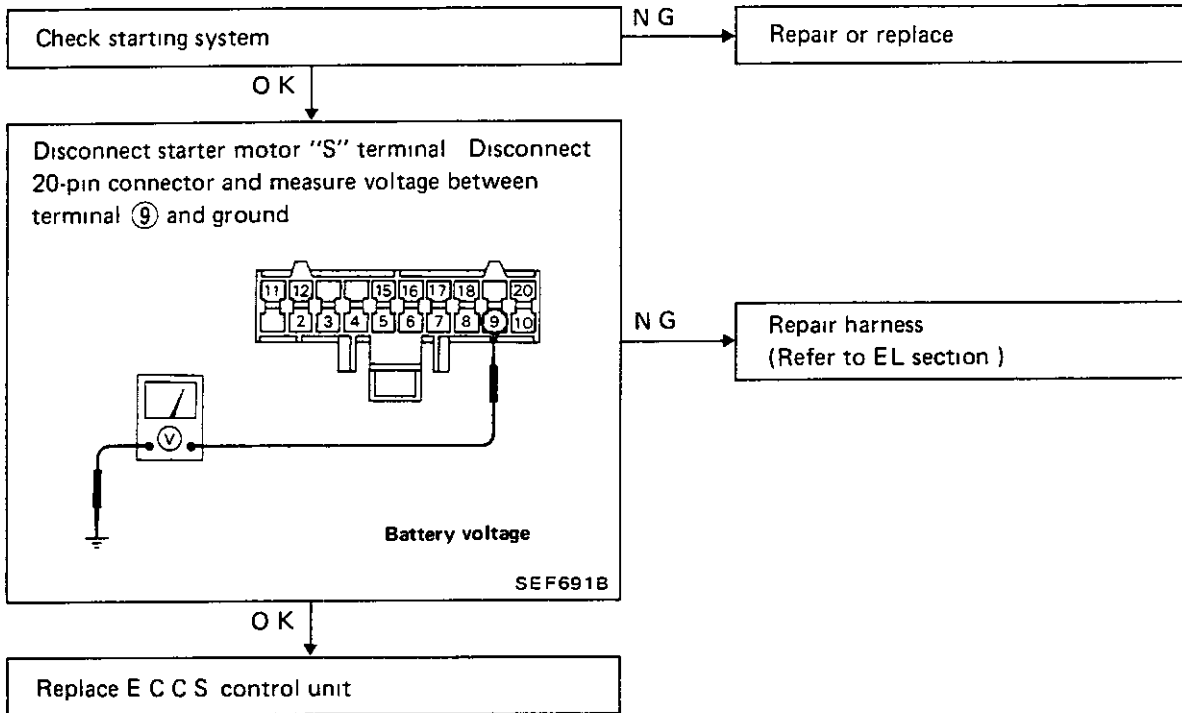

ⓑ Detonation sensor (Code No. 34)

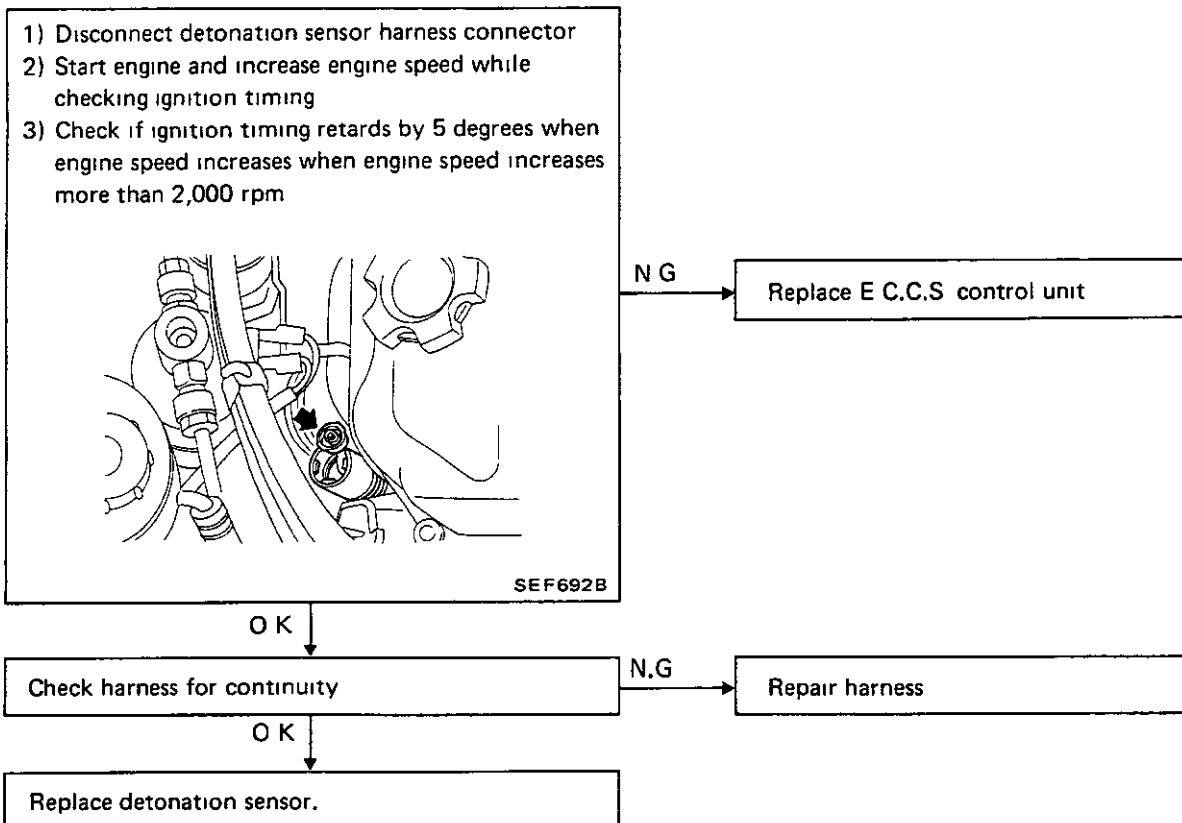

ELECTRONIC CONTROL SYSTEM INSPECTION

Ⓒ Fuel temperature sensor (Code No. 41)

Disconnect 20-pin connector and measure the resistance between terminal ⑮ and ground

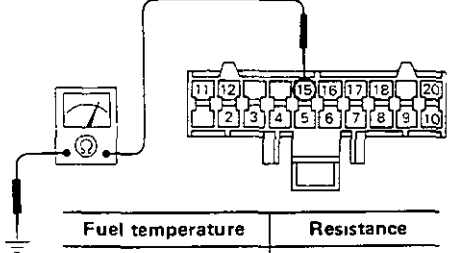

Fuel temperature	Resistance
Above 20°C (68°F)	Below 2.9 kΩ
Below 20°C (68°F)	Above 2.1 kΩ

SEF693B

OK

NG

Check harness for continuity

NG → Repair harness

OK

Measure the resistance of the fuel temperature sensor

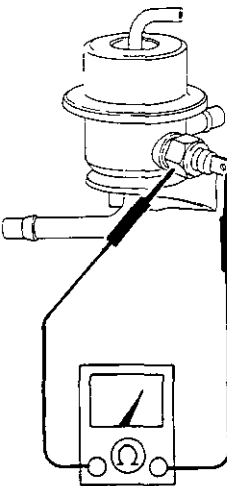

-10°C (14°F)	7.0 - 11.4 kΩ
20°C (68°F)	2.1 - 2.9 kΩ
50°C (122°F)	0.68 - 1.0 kΩ
80°C (176°F)	0.26 - 0.39 kΩ
100°C (212°F)	0.18 - 0.20 kΩ

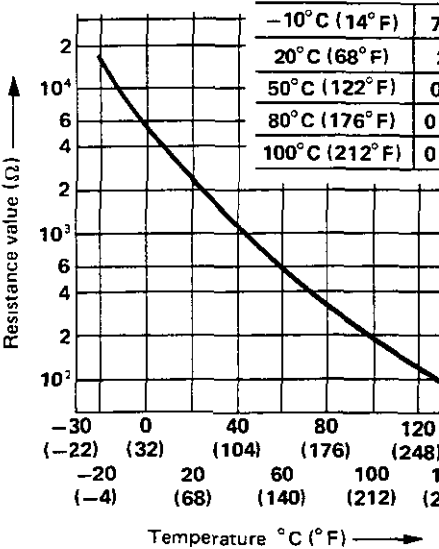

SEF694B

OK

NG

Replace E C C S control unit

Replace fuel temperature sensor and pressure regulator as an assembly

ELECTRONIC CONTROL SYSTEM INSPECTION

Ⓜ Auxiliary air control (A A.C.) valve or idle-up solenoid valve

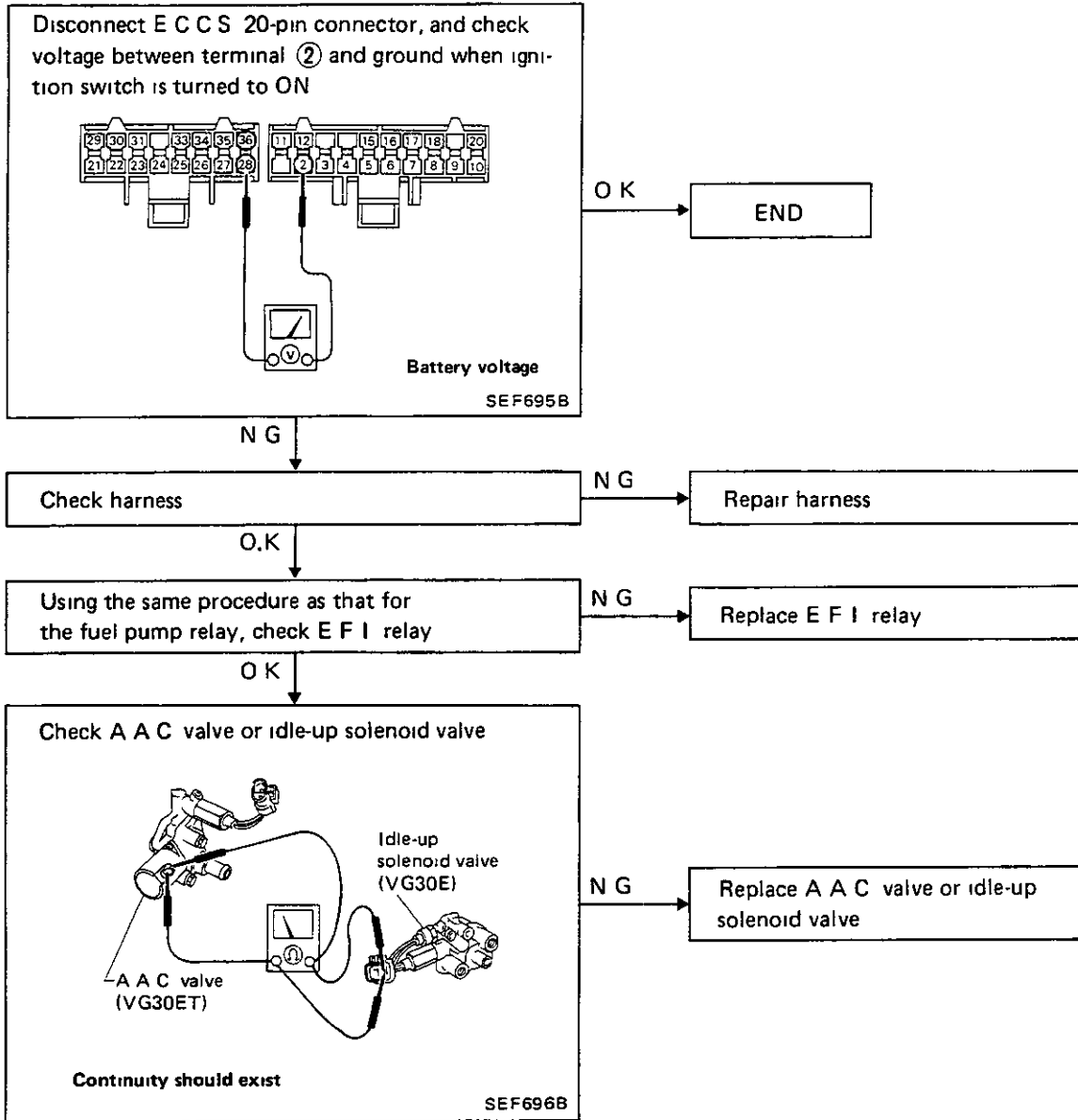

ELECTRONIC CONTROL SYSTEM INSPECTION

④ E.G.R. control valve

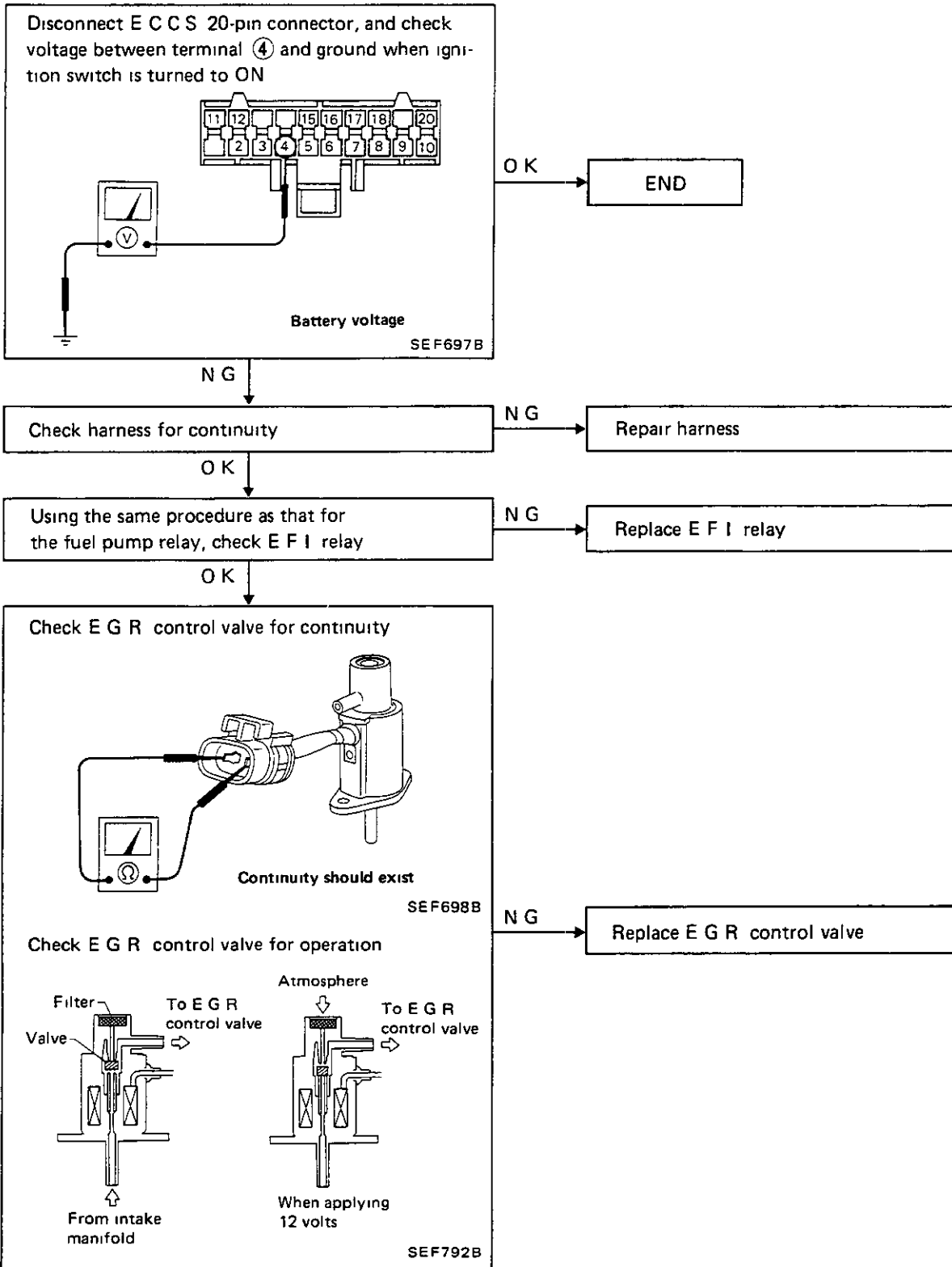

ELECTRONIC CONTROL SYSTEM INSPECTION

① Air regulator

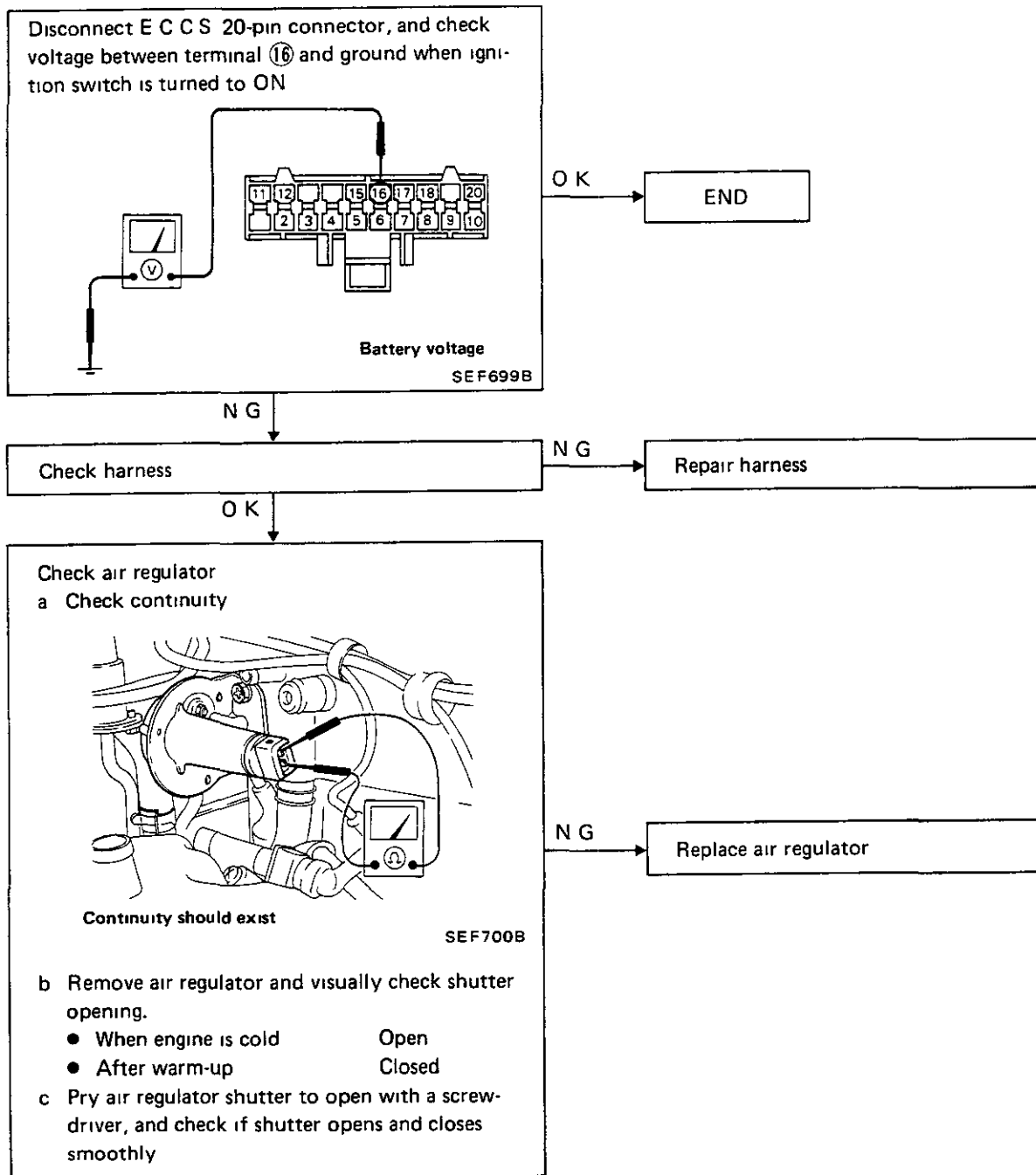

ELECTRONIC CONTROL SYSTEM INSPECTION

Ⓟ Exhaust gas sensor heater

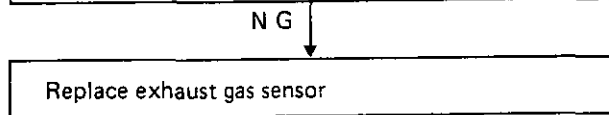
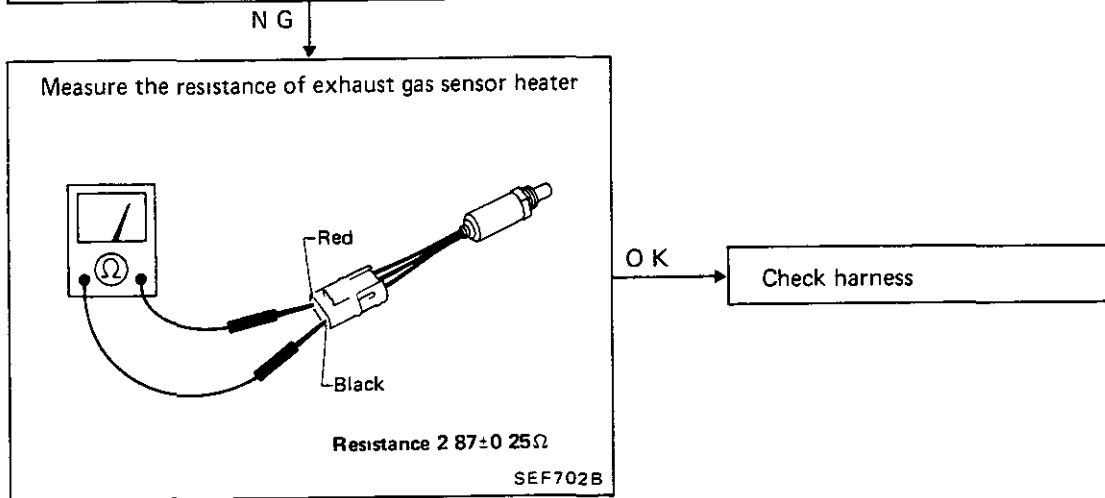
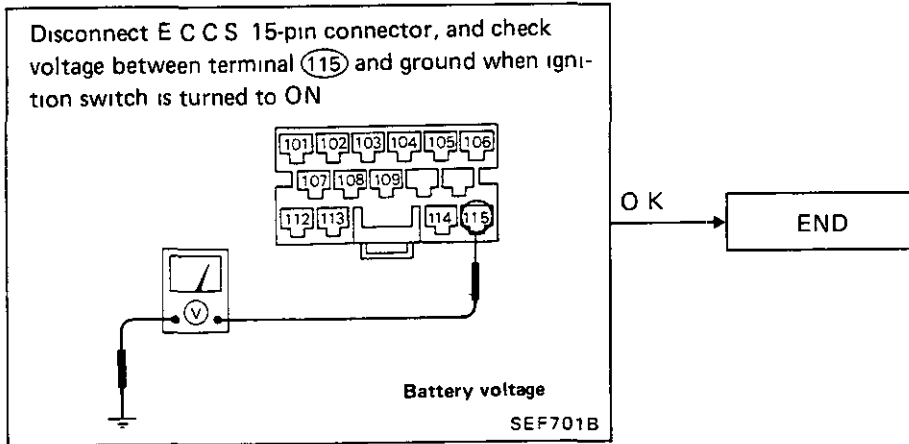

ELECTRONIC CONTROL SYSTEM INSPECTION

① Injector

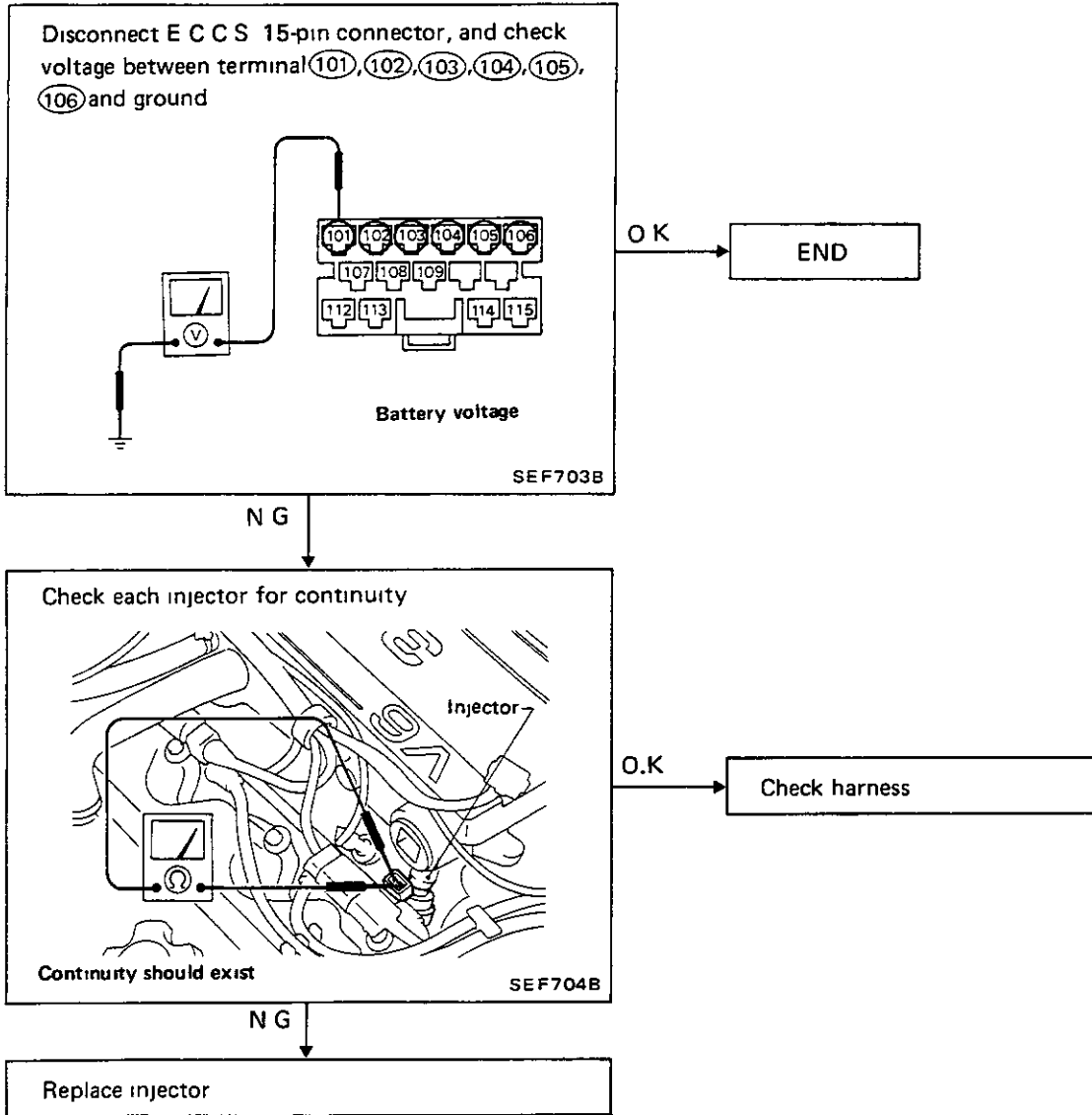

ELECTRONIC CONTROL SYSTEM INSPECTION

Ⓡ Battery source and ground

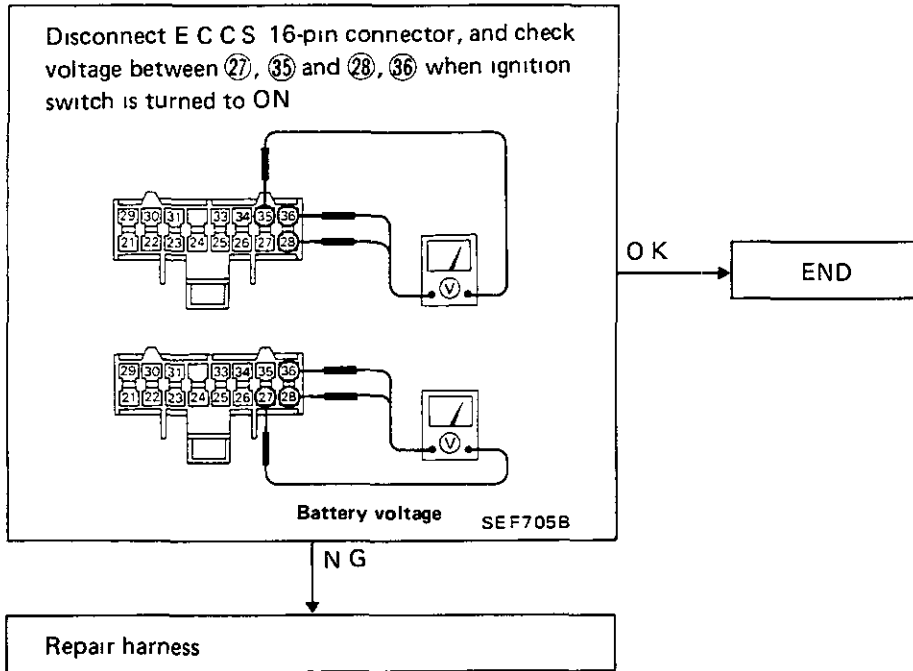

MIXTURE RATIO FEEDBACK SYSTEM INSPECTION

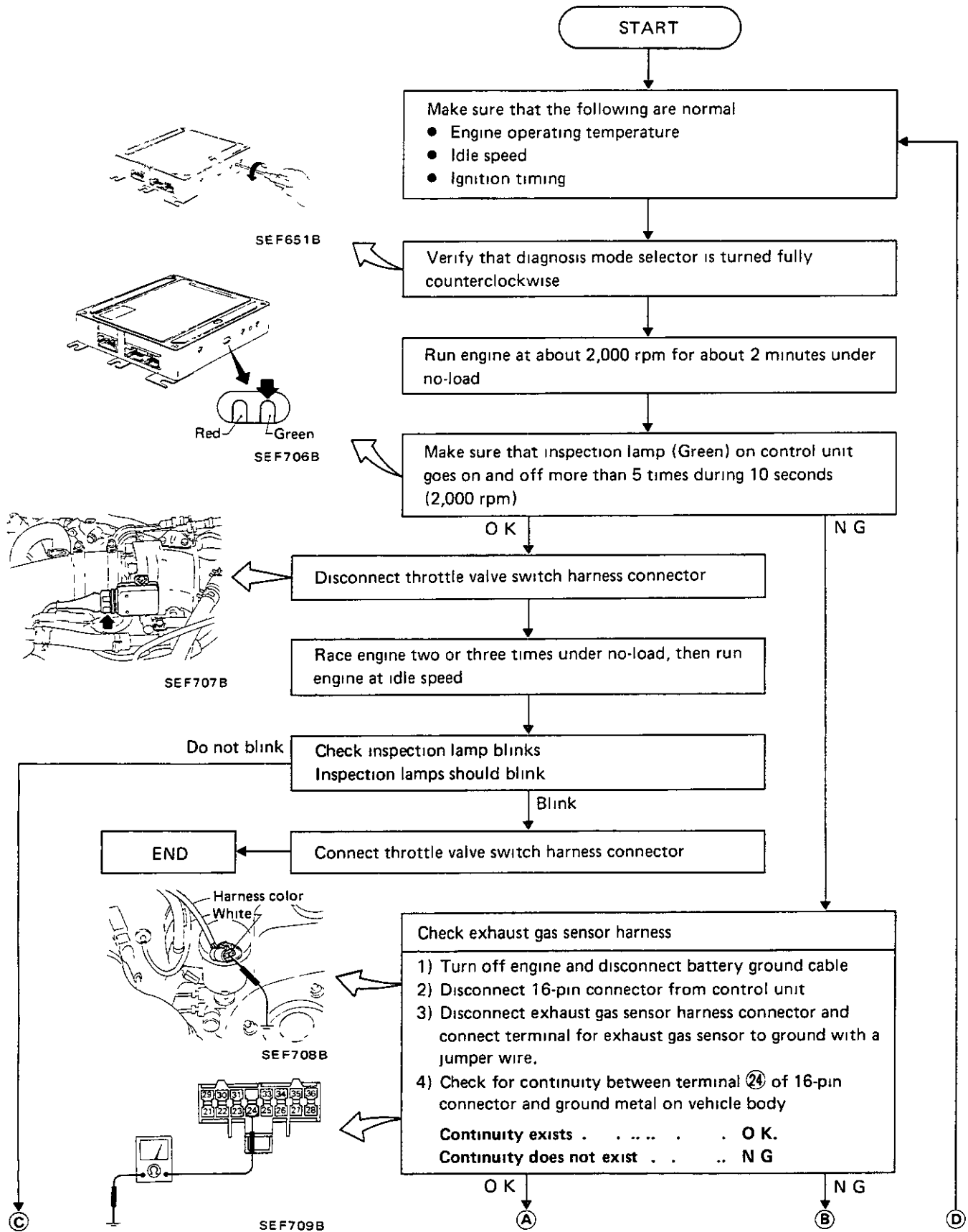

MIXTURE RATIO FEEDBACK SYSTEM INSPECTION

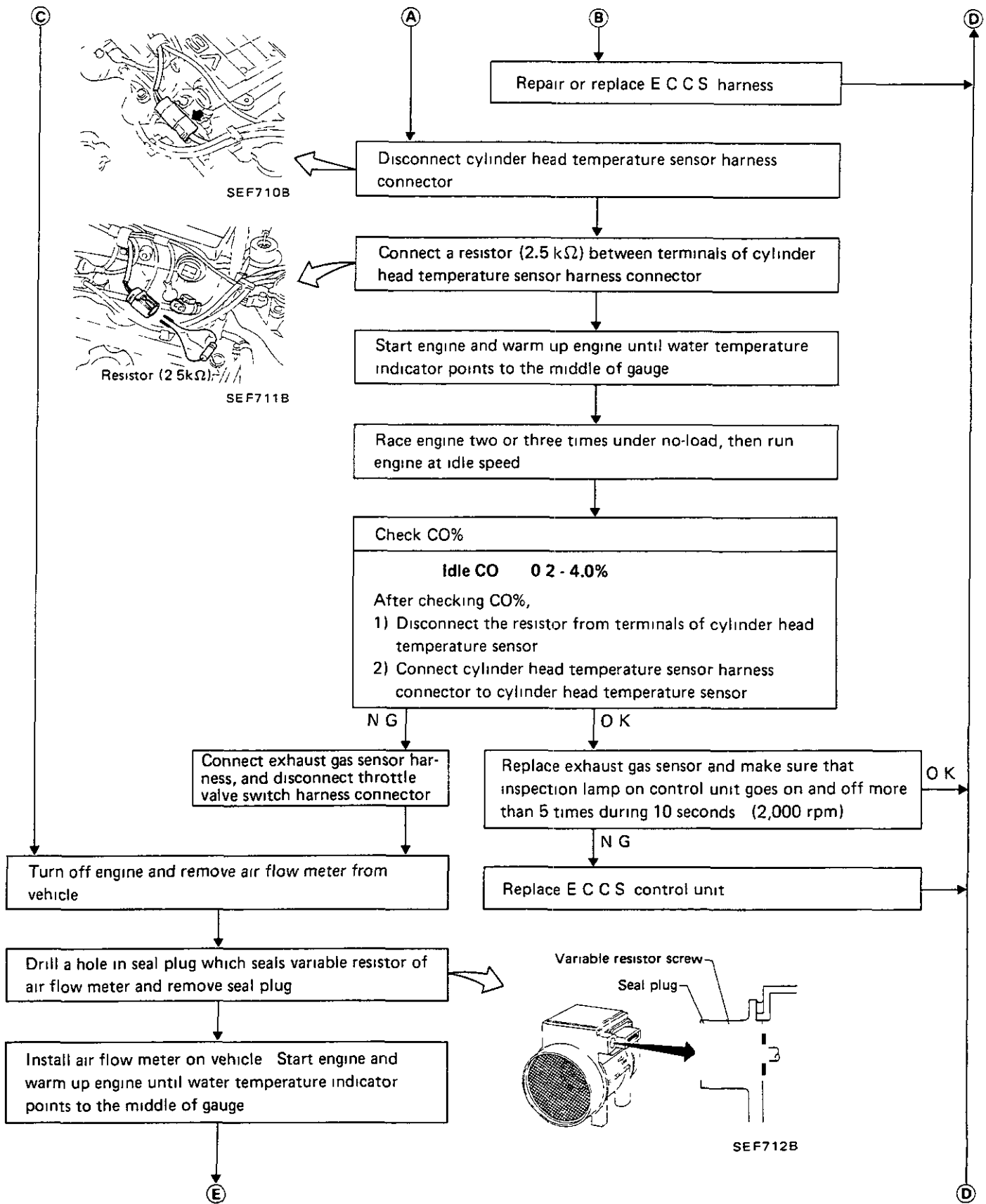

MIXTURE RATIO FEEDBACK SYSTEM INSPECTION

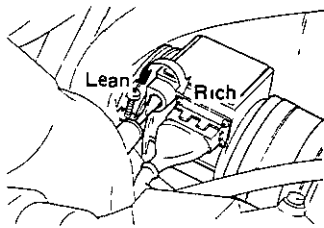

SEF649B

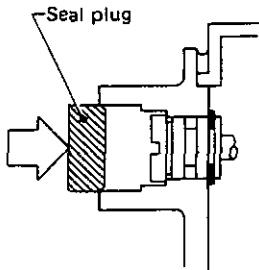

SEF713B

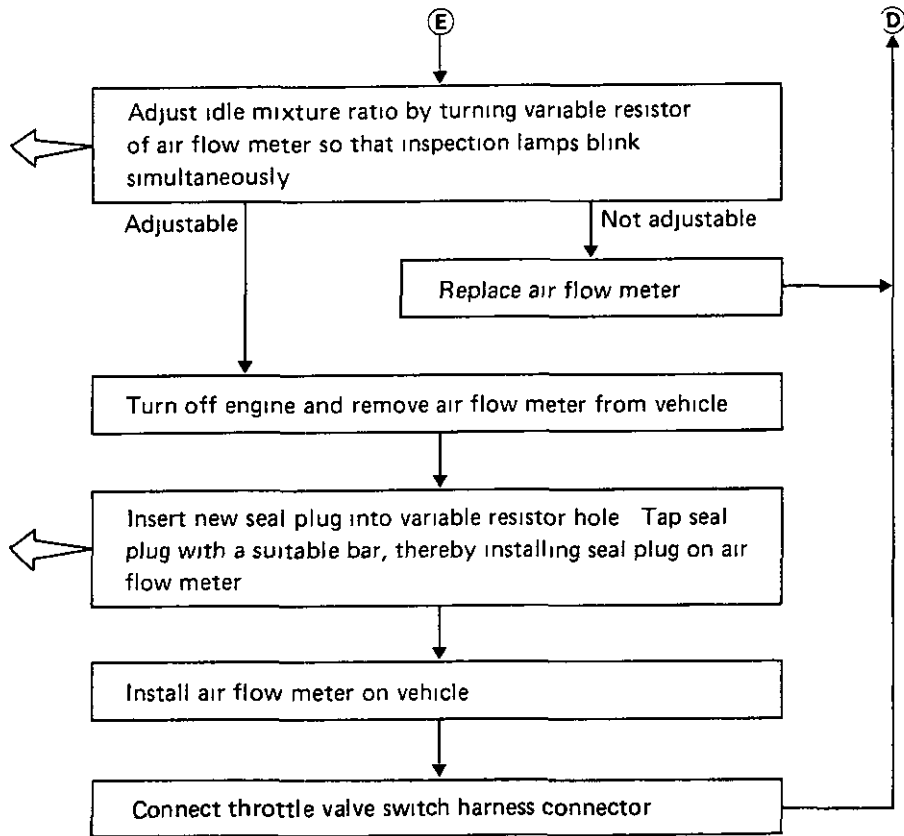

FUEL SYSTEM INSPECTION

Releasing Fuel Pressure

Before disconnecting fuel line, release fuel pressure from fuel line to eliminate danger.

- 1 Start engine
- 2 Remove luggage floor mat
- 3 Disconnect fuel pump connector with engine running

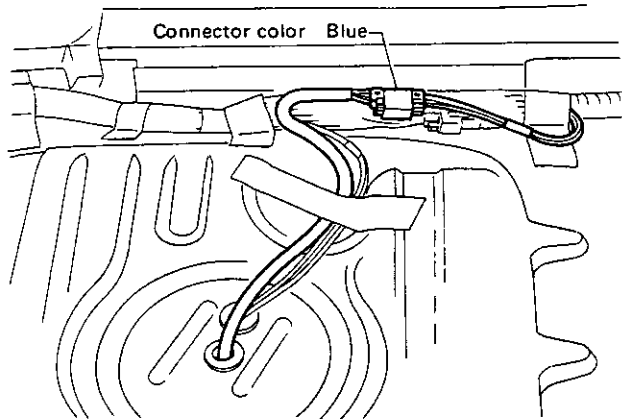

SEF714B

- 4 After engine stalls, crank engine two or three times to make sure that pressure is released
- 5 Turn ignition switch off and connect fuel pump connector.

Fuel Pressure Check

- a. When reconnecting fuel line, always use new clamps and be sure to position them correctly.
- b. Use a torque driver to tighten clamps.
- c. Use Pressure Gauge (J-2540034) to check fuel pressure.

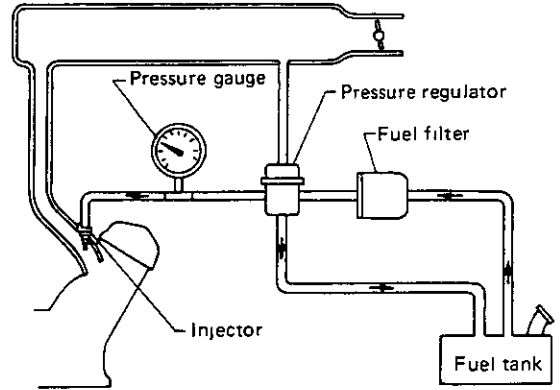

SEF715B

1. Release fuel pressure to zero
2. Disconnect fuel hose between fuel filter and fuel tube (engine side)
3. Install pressure gauge between fuel filter and fuel tube

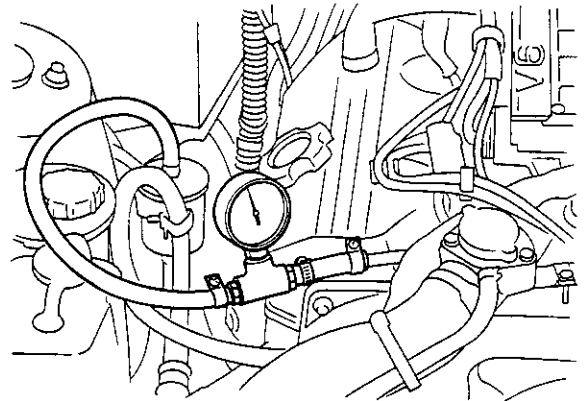

- 4 Start engine and check for fuel leakage.
- 5 Read the indication of fuel pressure gauge

At idling:

Approximately 206 kPa
(2.1 kg/cm² , 30 psi)

The moment accelerator pedal is fully depressed:

Approximately 255 kPa
(2.6 kg/cm² , 37 psi)

FUEL SYSTEM INSPECTION

Fuel Pressure Check (Cont'd)

- 6 Stop engine and disconnect fuel pressure regulator vacuum hose from intake collector
- 7 Plug intake collector with a rubber cap
- 8 Connect variable vacuum source (J-23738 or equivalent) to fuel pressure regulator.
- 9 Disconnect fuel pump connector and apply battery voltage as follows

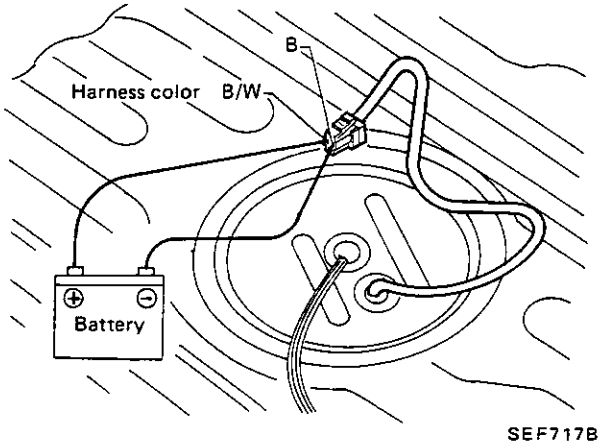

- 10 Start engine and read the indication of fuel pressure gauge as vacuum is changed

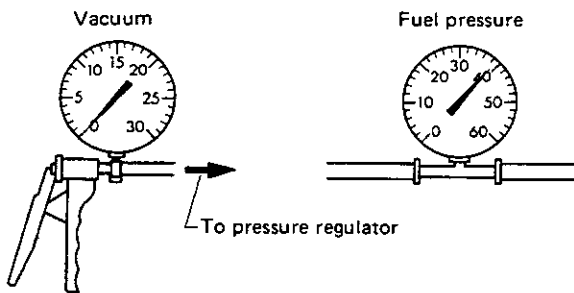

Vacuum kPa (mmHg, inHg)	Fuel pressure kPa (kg/cm ² , psi)
0 (0, 0)	248.1 - 255.0 (2.53 - 2.60, 36.0 - 37.0)
16.9 (127, 5.00)	227.5 - 241.3 (2.32 - 2.46, 33.0 - 35.0)
33.9 (254, 10.00)	213.8 - 220.7 (2.18 - 2.25, 31.0 - 32.0)
50.8 (381, 15.00)	200.1 - 206.9 (2.04 - 2.11, 29.0 - 30.0)
67.7 (508, 20.00)	179.5 - 193.2 (1.83 - 1.97, 26.0 - 28.0)

Fuel pressure should decrease as vacuum increases. If results are unsatisfactory, replace fuel pressure regulator.

FUEL SYSTEM INSPECTION

Injector Removal and Installation

- 1 Release fuel pressure to zero
- 2 Disconnect the following from intake collector.
 - Air duct
 - Accelerator wire
 - Blow-by hoses
 - Air regulator hose
 - E G R tube
 - Harness clamps
 - Harness connectors
 - Intake collector cover
- 3 Disconnect fuel hoses

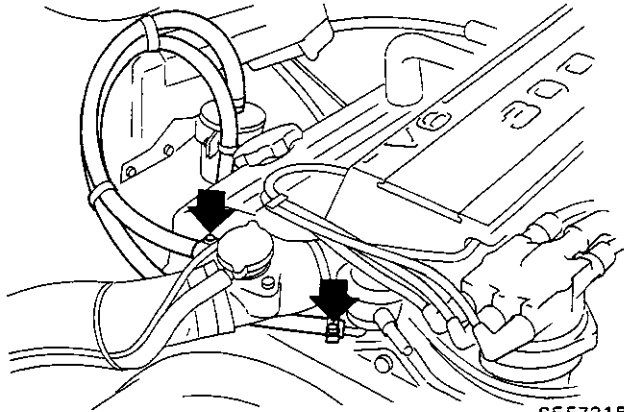

SEF721B

- 4 Remove intake collector

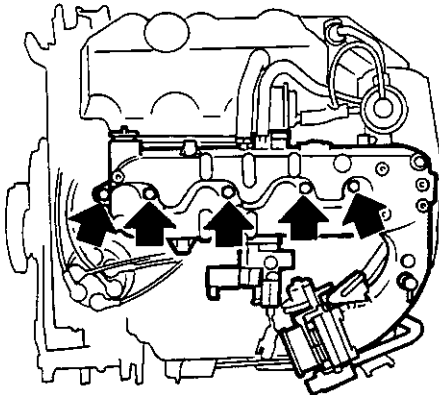

SEF720B

- 5 Remove bolts securing fuel tube

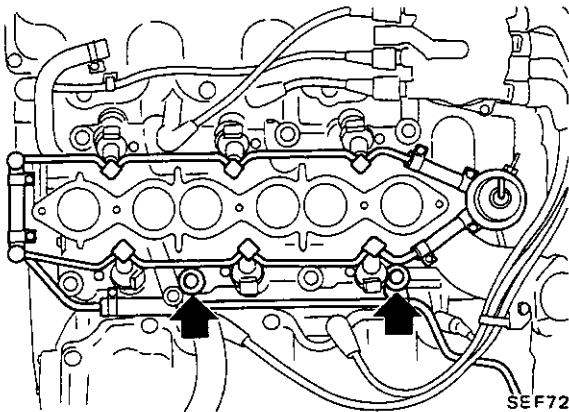

SEF722B

6. Remove bolts securing injectors and remove injectors, fuel tubes and pressure regulator as an assembly

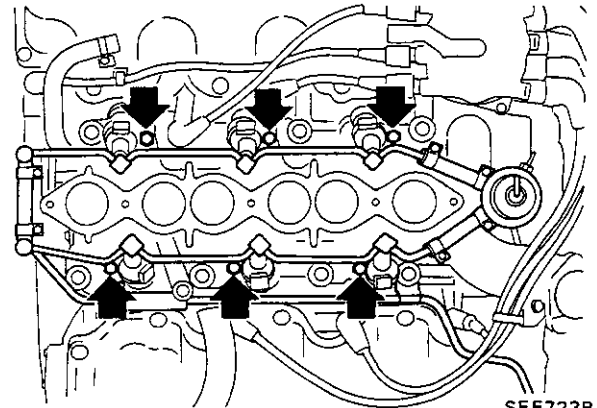

SEF723B

- 7 Remove fuel hose

- 1) Heat soldering iron (150 watt) for 15 minutes
Cut hose into braided reinforcement from mark to socket end and fuel tube end.

Do not feed soldering iron until it touches injector tail piece.

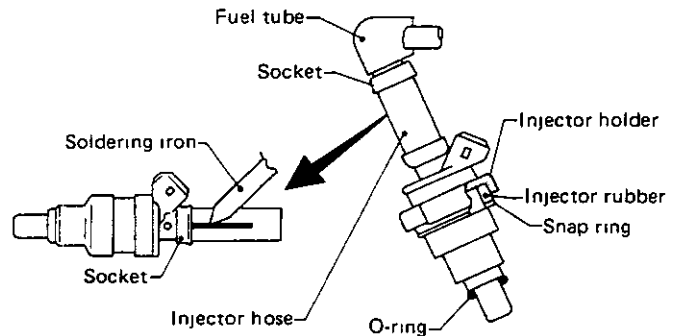

SEF719B

- 2) Then pull rubber hose out with hand.
 - a. Be careful not to damage socket plastic connector, etc. with soldering iron.
 - b. Never place injector in a vise when disconnecting rubber hose.
- 8 Install fuel hose as follows.
 - 1) Clean exterior of injector tail piece and fuel tube end.
 - 2) Wet inside of new rubber hose with fuel
 - 3) Push end of rubber hose with hose sockets onto injector tail piece and fuel tube end by hand as far as they will go

Clamp is not necessary at the connections.

CAUTION:

After properly connecting fuel hose to injector and fuel tube, check connection for fuel leakage.

TURBOCHARGER

Inspection

Condition 1 Low engine power

Probable cause

Air leak at the connection of compressor housing and suction hose/inlet tube, or inlet tube and intake manifold



Corrective action

Correct the connection

Exhaust gas leak at the connection of turbine housing and exhaust manifold, connecting tube or exhaust outlet



Correct the connection or replace gasket

By-pass valve is stuck open



Stuck or worn journal or bearing



Broken shaft



Sludge on back of turbine wheel



Broken turbine wheel



Replace turbocharger assembly

Condition 2 Excessively high engine power

Probable cause

Disconnected or cracked rubber hose



Corrective action

Correct or replace rubber hose

By-pass valve is stuck closed



Replace turbocharger assembly

Controller diaphragm is broken



TURBOCHARGER

Inspection (Cont'd)

Condition 3 Excessively high oil consumption or exhaust shows pale blue smoke

Probable cause

Oil leak at the connection of lubricating oil passage

Oil leak at oil seal of turbine

Oil leak at oil seal of compressor

Worn journal or bearing

Corrective action

Correct the connection

Replace turbocharger assembly

1. Inspect turbine and compressor wheel as follows

- Visually check for cracks, clogging, deformity or other damage
- Revolve wheels to make sure that they turn freely without any abnormal noise or friction
- Measure play in axial direction

Play (axial direction):

0.013 - 0.091 mm (0.0005 - 0.0036 in)

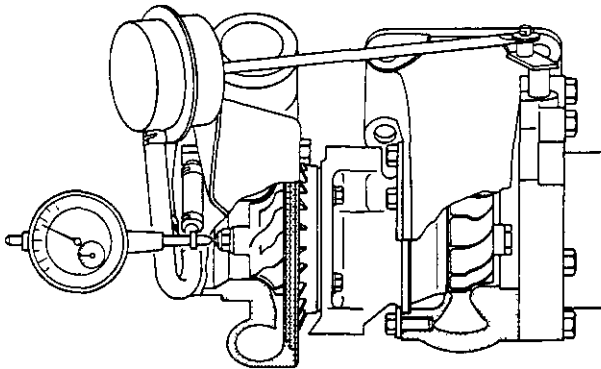

SEF726B

- 2 Check operation of by-pass valve controller
- Move by-pass valve to make sure that it is not sticking or scratched.
 - Measure rod end play of the by-pass valve controller

Do not apply more than 66.7 kPa (500 mmHg, 19.69 inHg) pressure to controller diaphragm

By-pass valve controller stroke/pressure:

0.38 mm (0.0150 in)/51.3 - 56.7 kPa
(385 - 425 mmHg, 15.16 - 16.73 inHg)

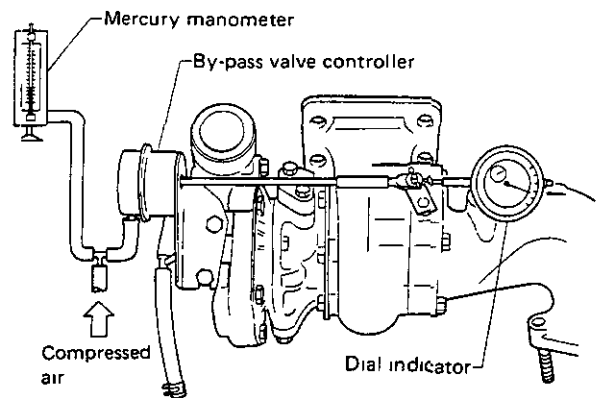

SEC727B

Always replace the turbocharger as an assembly if faulty

TURBOCHARGER

Removal and Installation

Turbocharger should not be disassembled

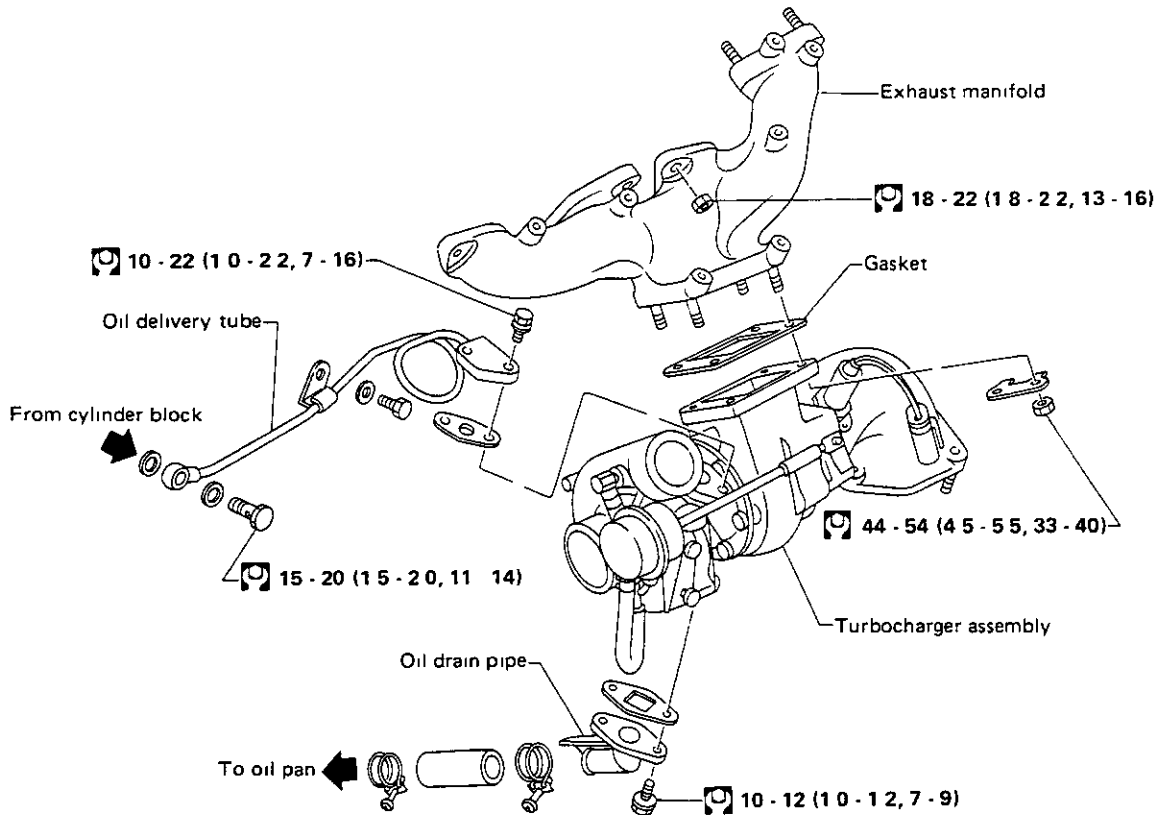

N m (kg-m, ft-lb)

SEF724B

- 1 Remove the following
 - Compressor and compressor bracket
 - Exhaust front tube
 - Center cable
 - Heat insulator for brake master cylinder
 - Air duct and hoses
 - Exhaust manifold connecting tube and heat shield plate
 - Oil delivery tube and return hose
- 2 Remove exhaust manifold and turbocharger as an assembly

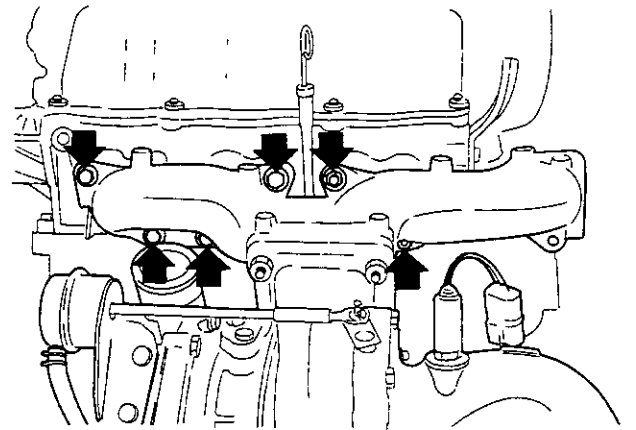

SEF725B

- 3 Disconnect the turbocharger from the exhaust manifold
- 4 When installing turbocharger to exhaust manifold, securely tighten nuts and bend up new lock washers

INJECTOR COOLING FAN (VG30ET)

Operation

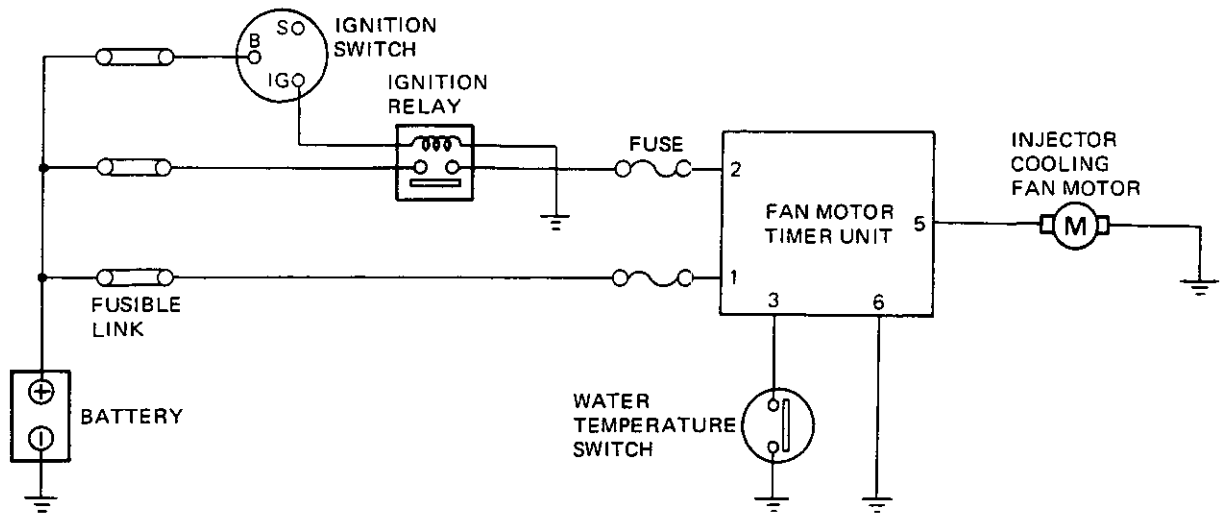

SEF728B

The injector cooling fan operates to cool down the temperature of fuel inside the injector and the fuel gallery when engine is stopped under high engine temperature condition

Operation 1

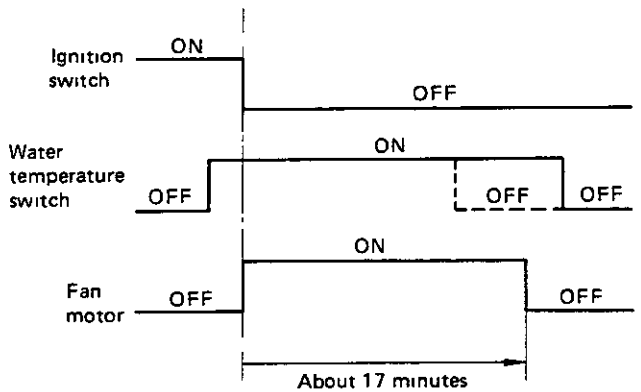

Operation 2

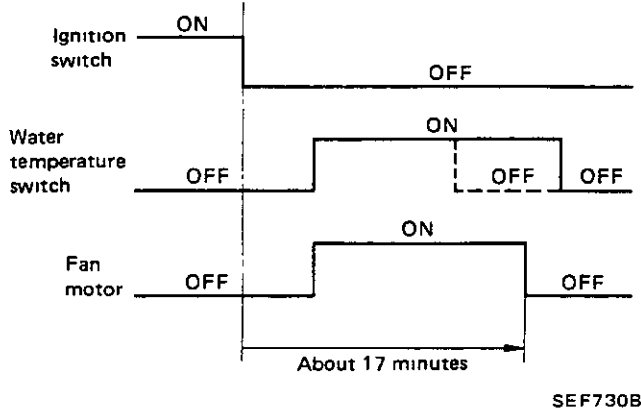

Operation 3

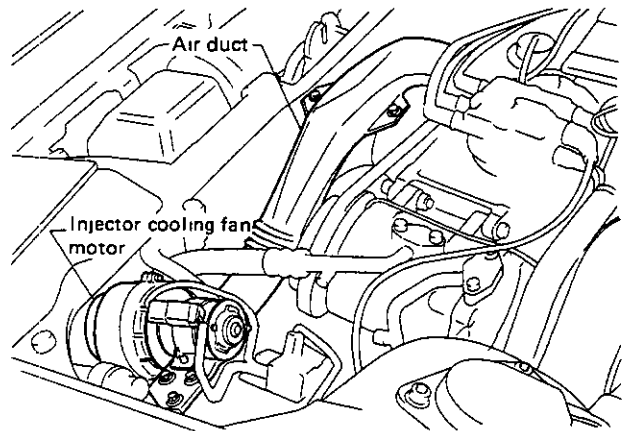
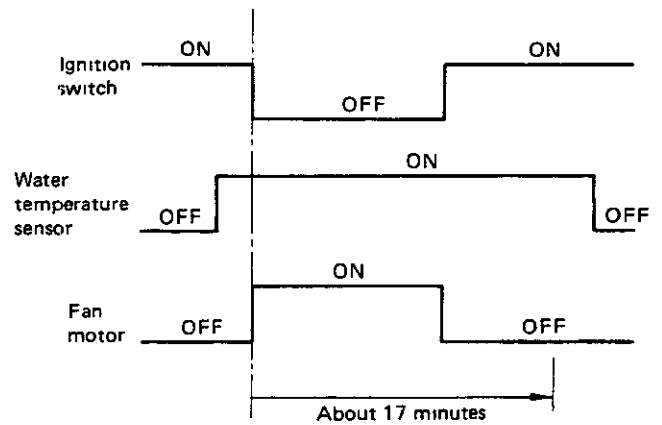

INJECTOR COOLING FAN (VG30ET)

Inspection

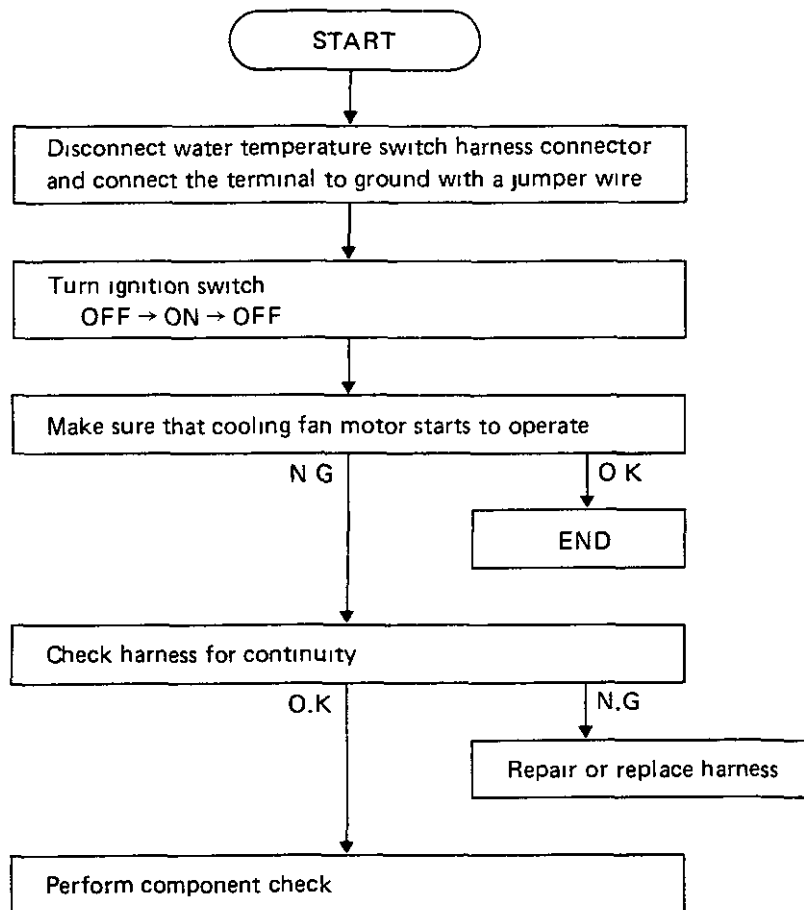

COMPONENT CHECK

A Fan motor

- 1 Make sure that continuity exists between terminals of fan motor

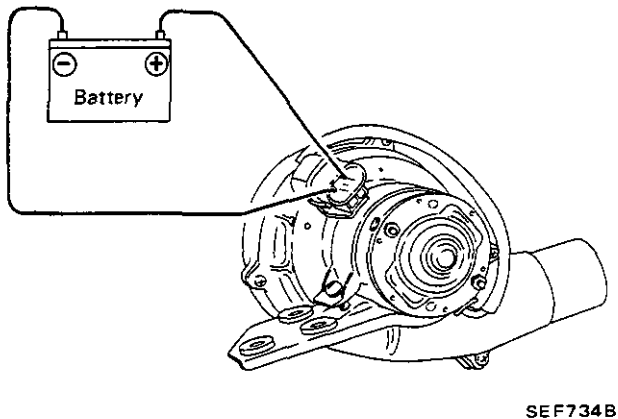

2. Apply battery voltage to the terminals of fan motor. If fan motor does not operate, replace

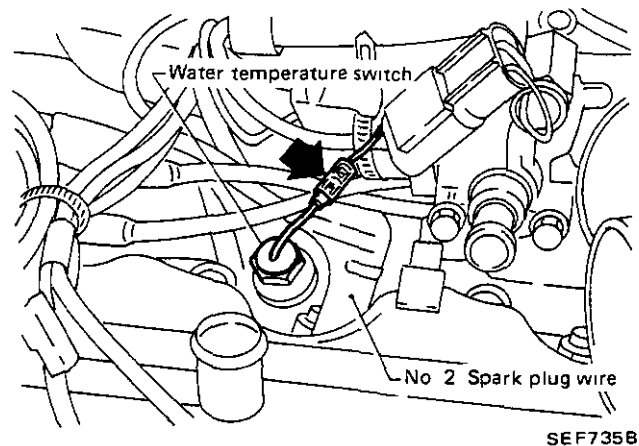

INJECTOR COOLING FAN (VG30ET)

Inspection (Cont'd)

B. Fan motor timer unit

Check the timer unit with a battery source and a bulb (12V-3W), following the procedure below

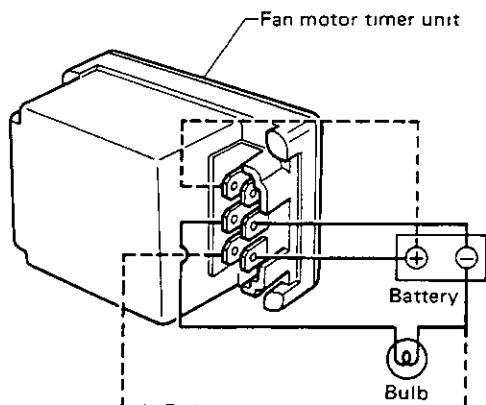

SEF736B

- 1 Connect terminal ⑥ to negative terminal of power source, terminal ⑤ to test lamp terminal and the other test lamp terminal to negative terminal of the power source
2. Connect terminal ① to positive terminal of power source
 - Test lamp does not glow O K
 - Test lamp glows N.G
- 3 Connect terminal ② to positive terminal of power source and disconnect it (Operate timer)
- 4 Connect terminal ③ to negative terminal of power source
 - Test lamp glows O K
 - Test lamp does not glow N.G.
5. Make sure that test lamp should remain on for about 17 minutes after step 3 is performed, and then go out.
6. While test lamp is on, connect terminal ② to positive terminal of power source.
 - Test lamp goes out O K.
 - Test lamp does not go out N G

C Water temperature switch

- 1 Remove water temperature switch

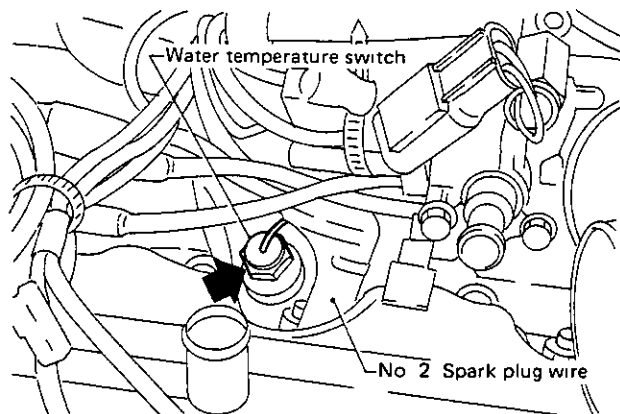

SEF737B

- 2 Check water temperature switch for proper operation

Operating temperature:

OFF → ON 80°C (176°F)

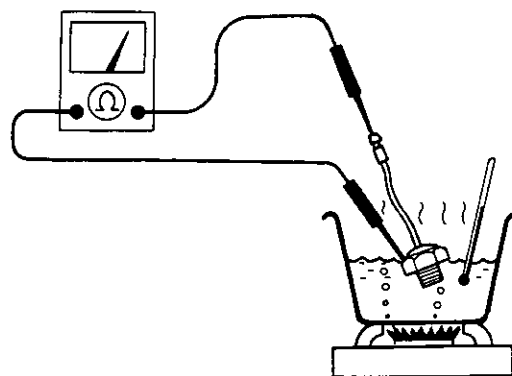

SEF738B

PRESSURE REGULATOR CONTROL

Operation

The pressure regulator control improves the starting of a hot engine by cutting off the intake manifold vacuum pressure and increasing the fuel pressure

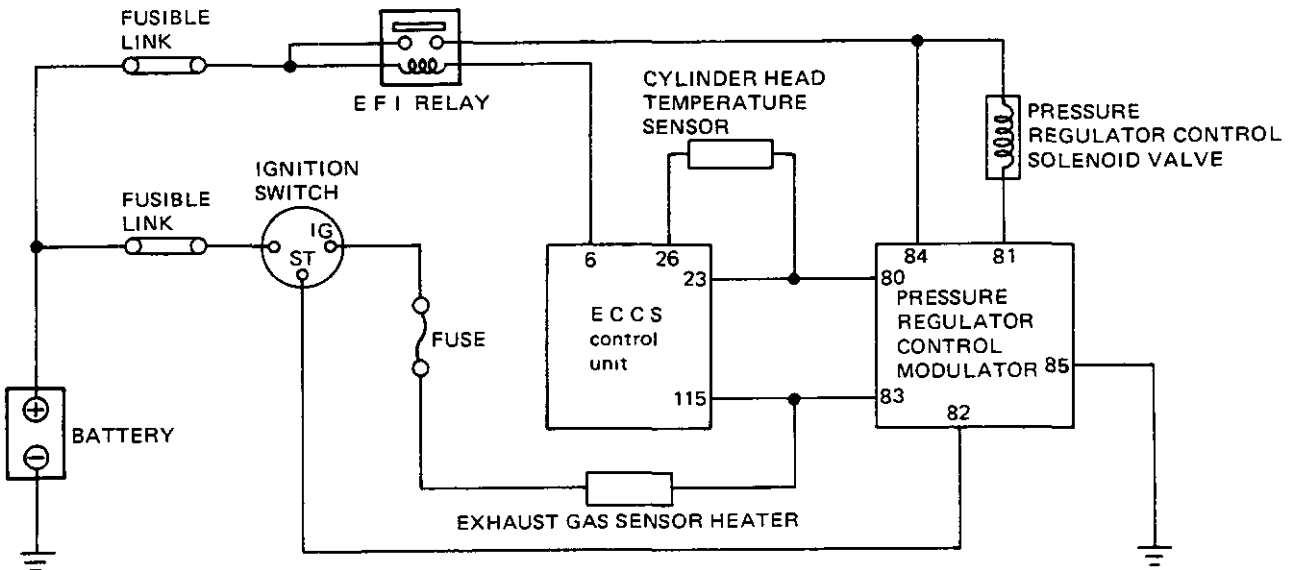
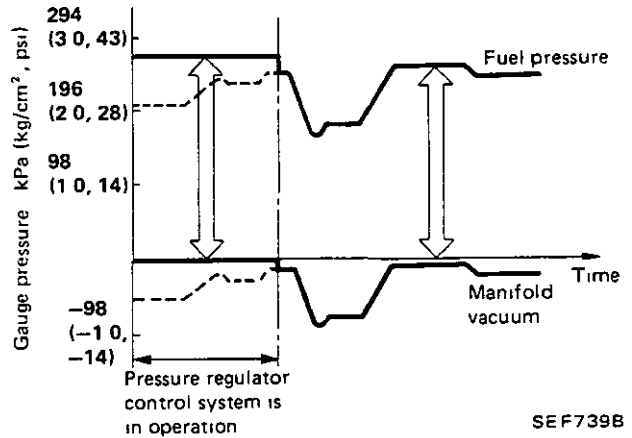

Operation

This system operates when all of the following conditions are met.

- Cylinder head temperature is above 100°C (212°F).
- During starting and after 3 minutes after starting

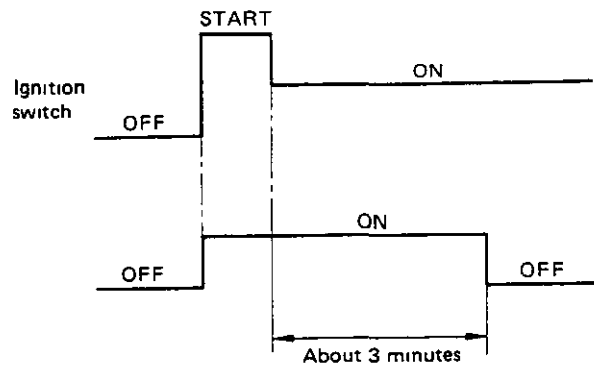

- Exhaust gas sensor heater is ON

PRESSURE REGULATOR CONTROL

Inspection

- 1 Disconnect cylinder head temperature sensor harness connector and connect terminals of harness connector with a lead wire

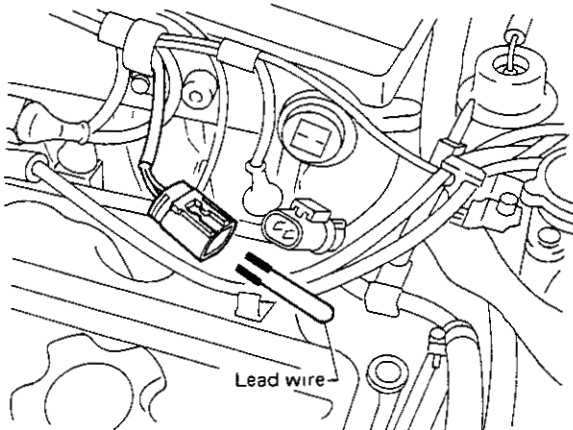

SEF742B

- 2 Disconnect a vacuum hose between pressure regulator and solenoid valve
- 3 Start engine and make sure that the vacuum does not exist for three minutes

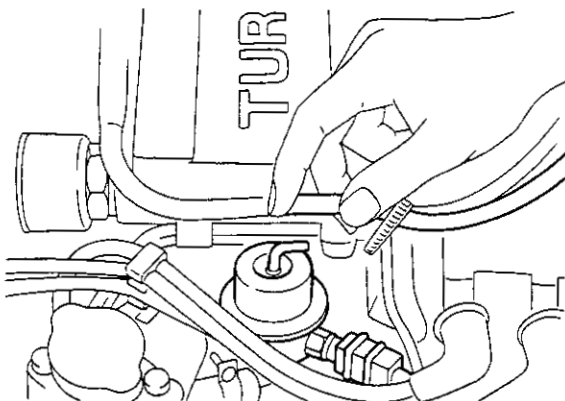

SEF743B

- 4 If vacuum exists, disconnect pressure regulator control modulator harness connector for the modulator located under the battery and check solenoid valve and circuit

- a Ignition switch OFF

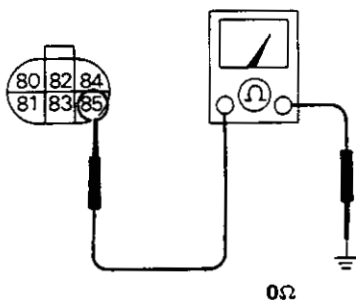

SEF744B

- b Ignition switch ON

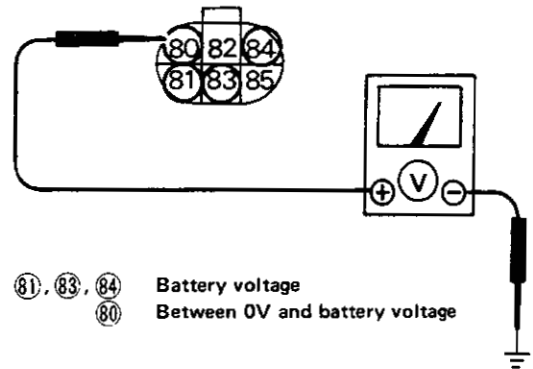

SEF745B

- c Ignition switch START
Disconnect starter motor "S" terminal

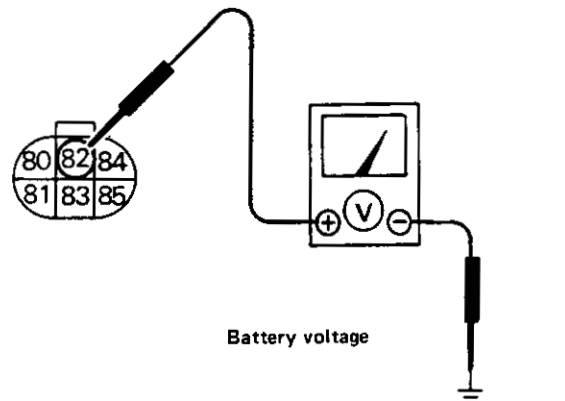

SEF746B

- d Check continuity between terminals of solenoid valve

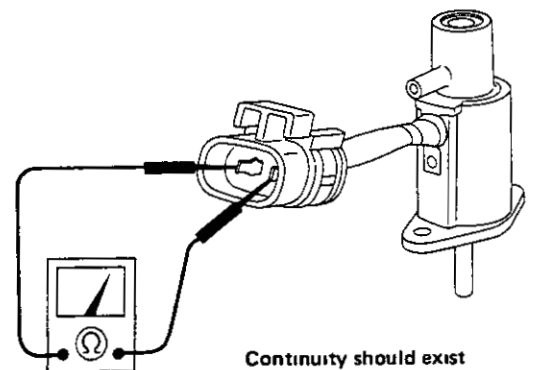

SEF698B

- 5 If solenoid valve and circuit are O.K., replace pressure regulator control modulator.

CRANKCASE EMISSION CONTROL SYSTEM

VG30E ENGINE (Without turbocharger)

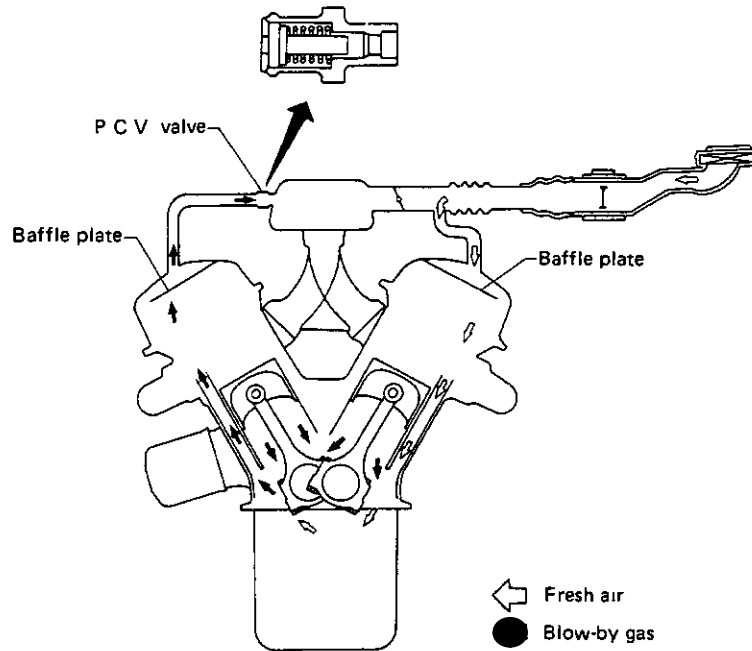

SEC301A

VG30ET ENGINE (With turbocharger)

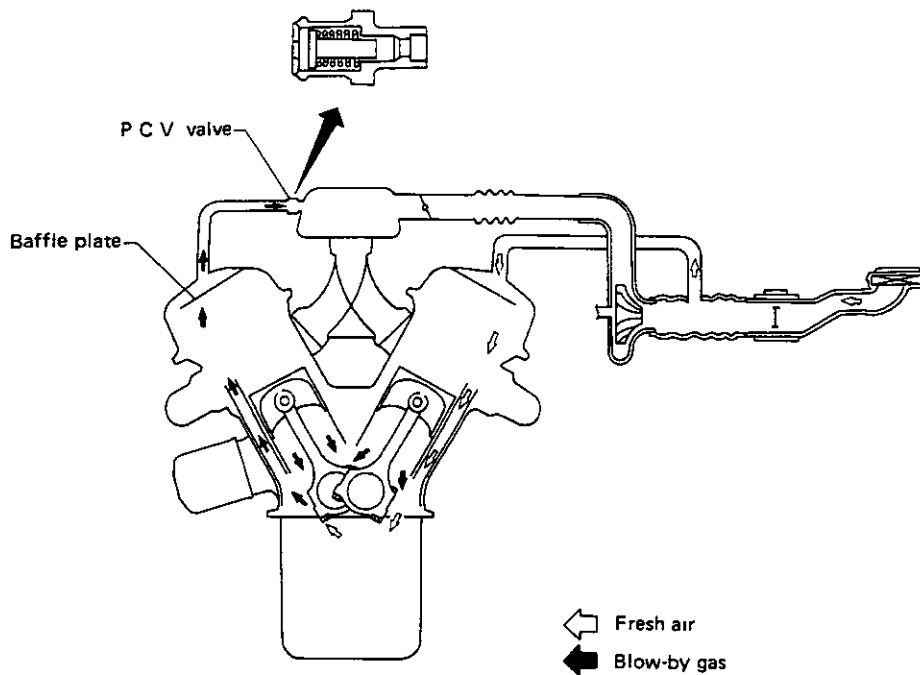

SEC302A

This system is designed to return the blow-by gas to the intake manifold and to charge fresh air into

the crankcase. The positive crankcase ventilation (P C V.) valve is provided

EXHAUST EMISSION CONTROL SYSTEM

Intake Manifold Vacuum Control

The vacuum control valve is provided to reduce the engine lubricating oil consumption when the intake manifold vacuum increases to a very high level during deceleration

The vacuum control valve senses the manifold vacuum. As the manifold vacuum increases beyond the specified value, the valve opens and air is sucked into the intake manifold

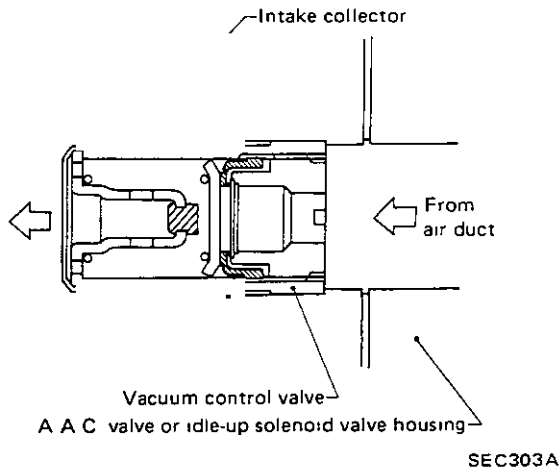

Catalytic Converter

The exhaust gas contains unburned, harmful gases. While the mixture ratio is maintained to the stoichiometric point by the mixture ratio feedback system, the three-way catalytic converter activates to oxidize and reduce harmful gases (HC, CO and NO_x) into harmless gases (CO₂, H₂O and N₂). In this way, the catalytic converter cleans the exhaust gas and emits CO₂, H₂O and N₂ into the atmosphere

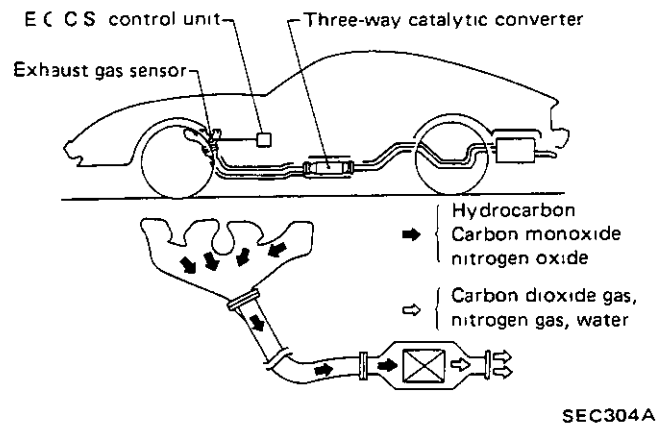

EVAPORATIVE EMISSION CONTROL SYSTEM

Operation

The fuel vapor from the sealed fuel tank is led into the canister which contains activated carbon and the vapor is stored there when the engine is not running.

The canister retains the fuel vapor until the canister is purged by the air drawn through the purge line to the intake manifold when the engine is running. When the engine runs at idle, the purge

control valve is closed.

Only a small amount of purge air flows into the intake manifold through the constant purge orifice. As the engine speed increases, and the throttle vacuum rises higher, the purge control valve opens and the vapor is sucked into the intake manifold through both the fixed orifice and the constant purge orifice.

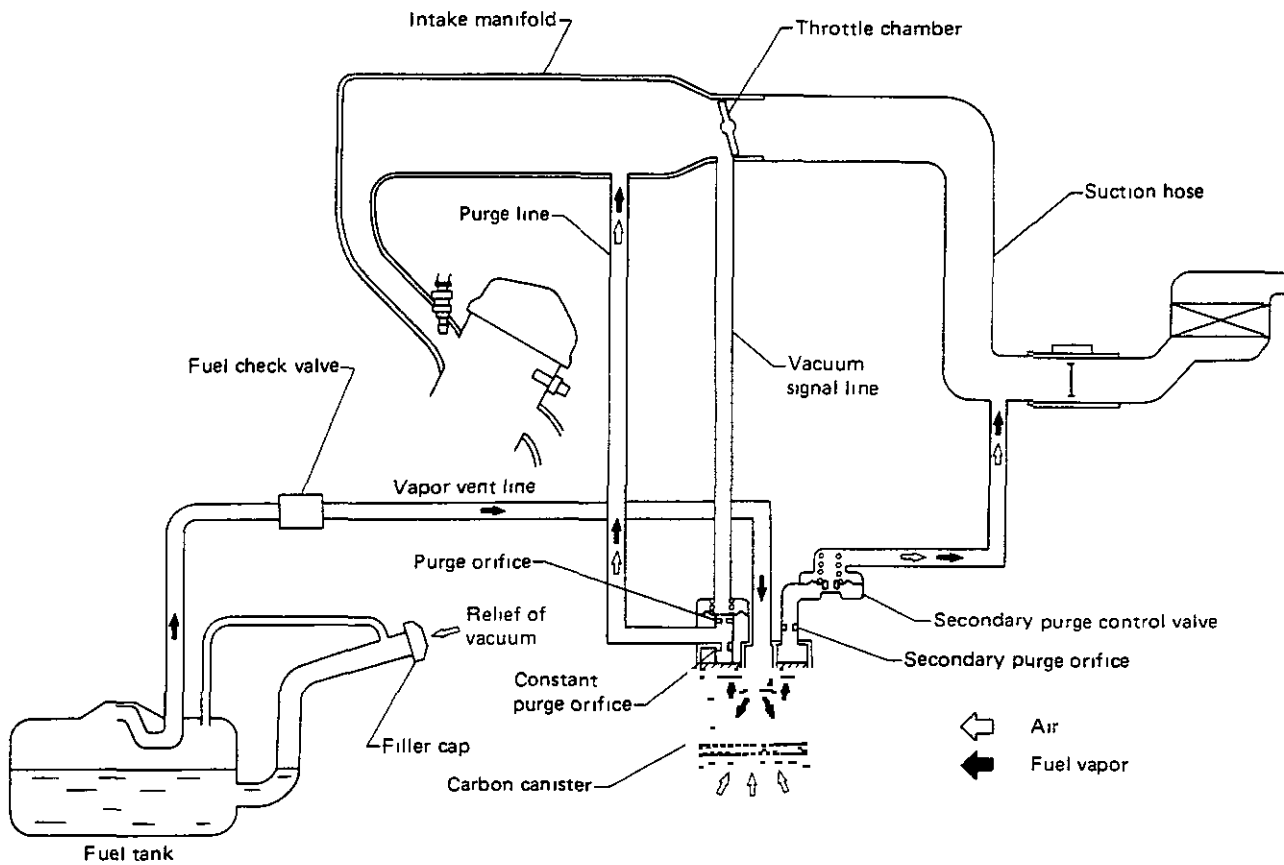

SEC305A

EVAPORATIVE EMISSION CONTROL SYSTEM

Inspection

VAPOR VENT LINE

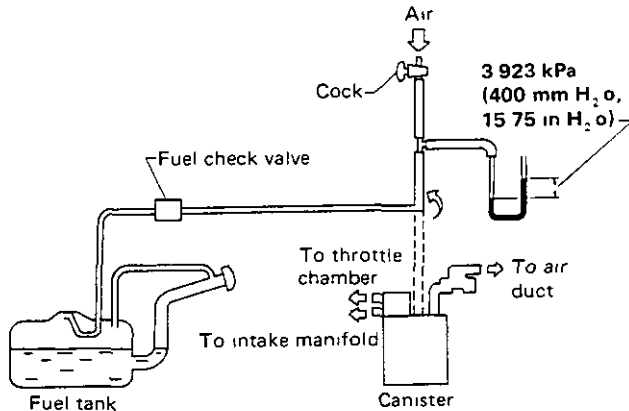

SEC306A

- 1 Check hoses and fuel tank filler cap
- 2 Disconnect the vapor vent line connecting carbon canister to fuel tank
- 3 Connect a 3-way connector, a manometer and a cock (or an equivalent 3-way charge cock) to the end of the vent line
- 4 Supply fresh air into the vapor vent line through the cock little by little until pressure becomes 3 923 kPa (400 mmH₂O, 15 75 inH₂O)
- 5 Shut the cock completely and leave it unattended
- 6 After 2 5 minutes, measure the height of the liquid in the manometer
- 7 Variation in height should remain at 0.245 kPa (25 mmH₂O, 0 98 inH₂O)
- 8 When filler cap does not close completely, the height should drop to zero in a short time
- 9 If the height does not drop to zero in a short time when filler cap is removed, the cause is a stuffy hose.

In case the vent line is stuffy the breathing in fuel tank is not thoroughly made thus causing insufficient deliver of fuel to engine or vapor lock. It must, therefore, be repaired or replaced.

CARBON CANISTER

Check carbon canister as follows

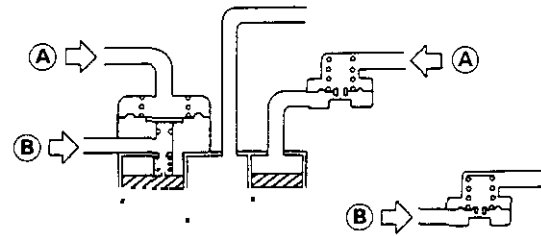

- (A) Inhale air and ensure that there is no leakage
- (B) Inhale air and ensure that there is leakage

SEC307A

If malfunctioning, replace faulty part

FUEL TANK VACUUM RELIEF VALVE

- 1 Wipe clean valve housing and have it in your mouth
- 2 Inhale air A slight resistance accompanied by valve indicates that valve is in good mechanical condition Note also that, by further inhaling air, the resistance should be disappeared with valve clicks
3. If valve is clogged, or if no resistance is felt, replace cap as an assembled unit

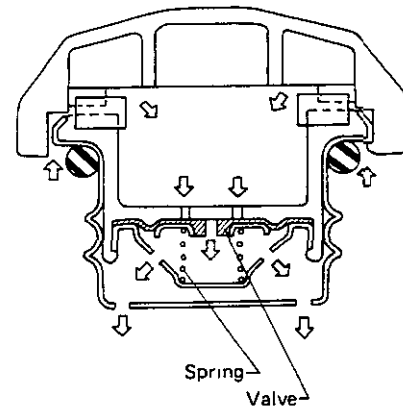

SEC308A

EVAPORATIVE EMISSION CONTROL SYSTEM

Inspection (Cont'd)

FUEL CHECK VALVE

- 1 Blow air through connector on fuel tank side
A considerable resistance should be felt at the mouth and a portion of air flow be directed toward the engine
- 2 Blow air through connector on engine side
Air flow should be smoothly directed toward fuel tank
- 3 If fuel check valve is suspected of not being properly functioning in steps 1 and 2 above, replace.

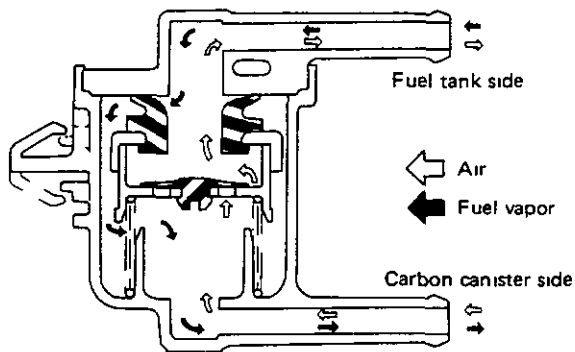

SEC309A

SERVICE DATA AND SPECIFICATIONS (S.D.S.)

General Specifications

Fuel pump	
Cut-off discharge pressure kPa (kg/cm ² , psi)	422 - 490 (4.3 - 5.0, 61 - 71)
Pressure regulator	
Regulated pressure kPa (kg/cm ² , psi)	250.1 (2.55, 36.3)
Air regulator	
Air flow amount [at 20°C (68°F)] m ³ (cu ft)/hr	27.5 (971)
Turbocharger	
Max supercharging pressure kPa (mmHg, inHg)	42.7 - 50.7 (320 - 380, 12.60 - 14.96)
Emergency relief valve	
Valve opening pressure kPa (mmHg, inHg)	50.7 - 53.3 (380 - 400, 14.96 - 15.75)

Inspection and Adjustment

Fuel pressure	
At idle kPa (kg/cm ² , psi)	Approximately 206 (2.1, 30)
The moment accelerator pedal is fully depressed kPa (kg/cm ² , psi)	Approximately 255 (2.6, 37)
Air flow meter	
Voltage between terminals B and D	1.6 ± 0.1 V
Cylinder head temperature sensor and fuel temperature sensor	
Thermistor resistance at -10°C (14°F)	7.0 - 11.4 kΩ
at 20°C (68°F)	2.1 - 2.9 kΩ
at 50°C (122°F)	0.68 - 1.0 kΩ
Throttle valve switch	
Engine speed when idle switch is turned from "ON" to "OFF"	Approximately 900 rpm
Exhaust gas sensor	
Heater resistance	2.6 - 3.1 Ω

Tightening Torque

Unit	N·m	kg·m	ft·lb
Throttle chamber securing bolt	18 - 22	1.8 - 2.2	13 - 16
Intake collector bolt	18 - 22	1.8 - 2.2	13 - 16
Cylinder head temperature sensor	12 - 16	1.2 - 1.6	9 - 12
Exhaust gas sensor	40 - 50	4.1 - 5.1	30 - 37
EGR control valve	18 - 23	1.8 - 2.3	13 - 17
EGR tube	34 - 44	3.5 - 4.5	25 - 33
Detonation sensor	25 - 34	2.5 - 3.5	18 - 25
Fuel hose clamp	1.0 - 1.5	0.10 - 0.15	0.7 - 1.1