

SERVICE MANUAL

DATSUN 240Z SPORTS
MODEL S30 SERIES
CHASSIS & BODY



NISSAN MOTOR CO., LTD.
TOKYO, JAPAN

SECTION BE

BODY ELECTRICAL

WIRING	BE- 1
LAMPS	BE- 6
METERS	BE- 9
WINDSHIELD WIPER	BE-15
WINDSHIELD WASHER	BE-18
SWITCH	BE-19
HORN AND HORN RELAY	BE-22
RADIO	BE-24
CLOCK	BE-27
REAR WINDOW ELECTRIC DEFROSTER	BE-28

BE

BODY ELECTRICAL

WIRING

CONTENTS

ENGINE COMPARTMENT HARNESS
Wiring instructions
INSTRUMENT HARNESS

BE-1	BODY HARNESS	BE-3
BE-1	Wiring instructions	BE-3
BE-2	WIRING DIAGRAM	BE-4

ENGINE COMPARTMENT HARNESS

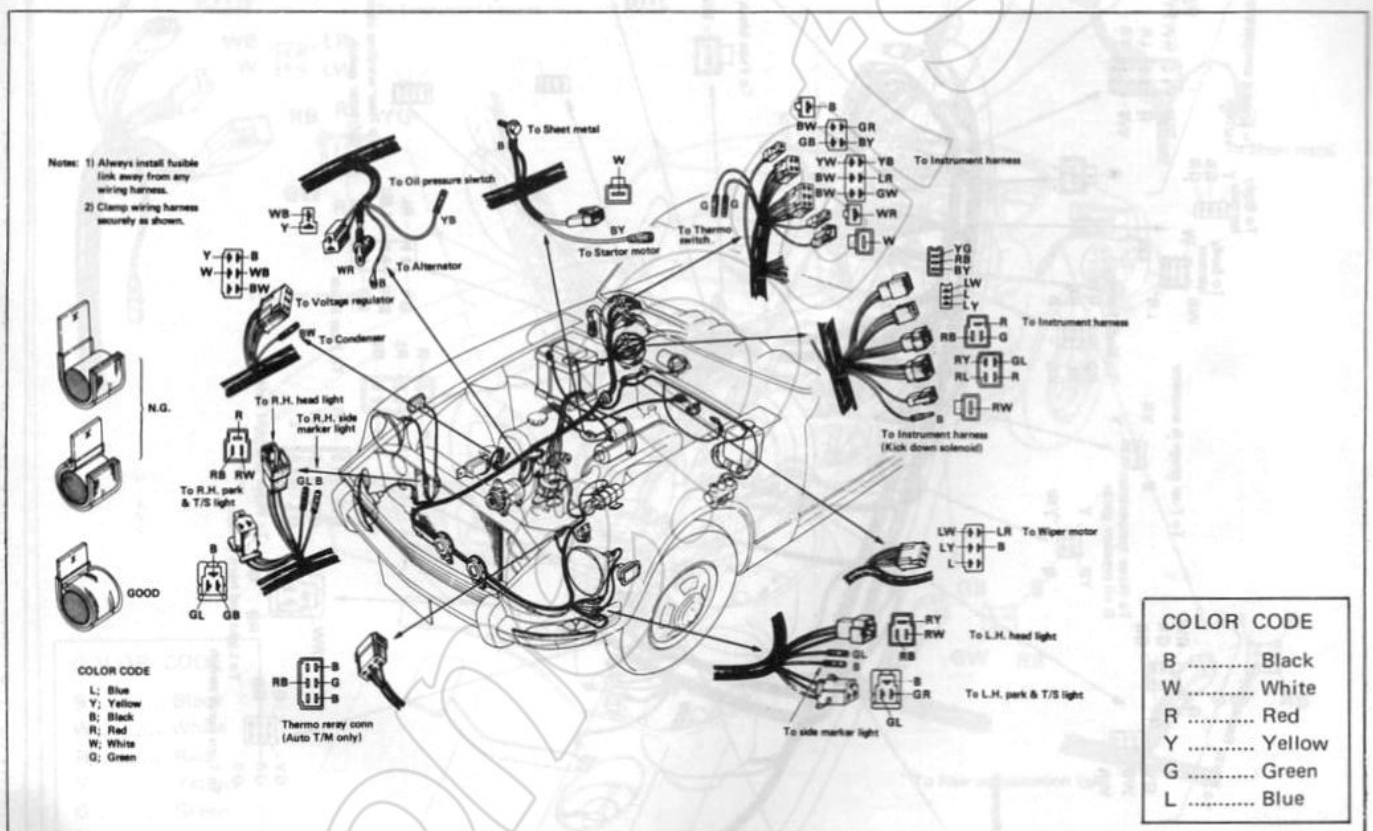
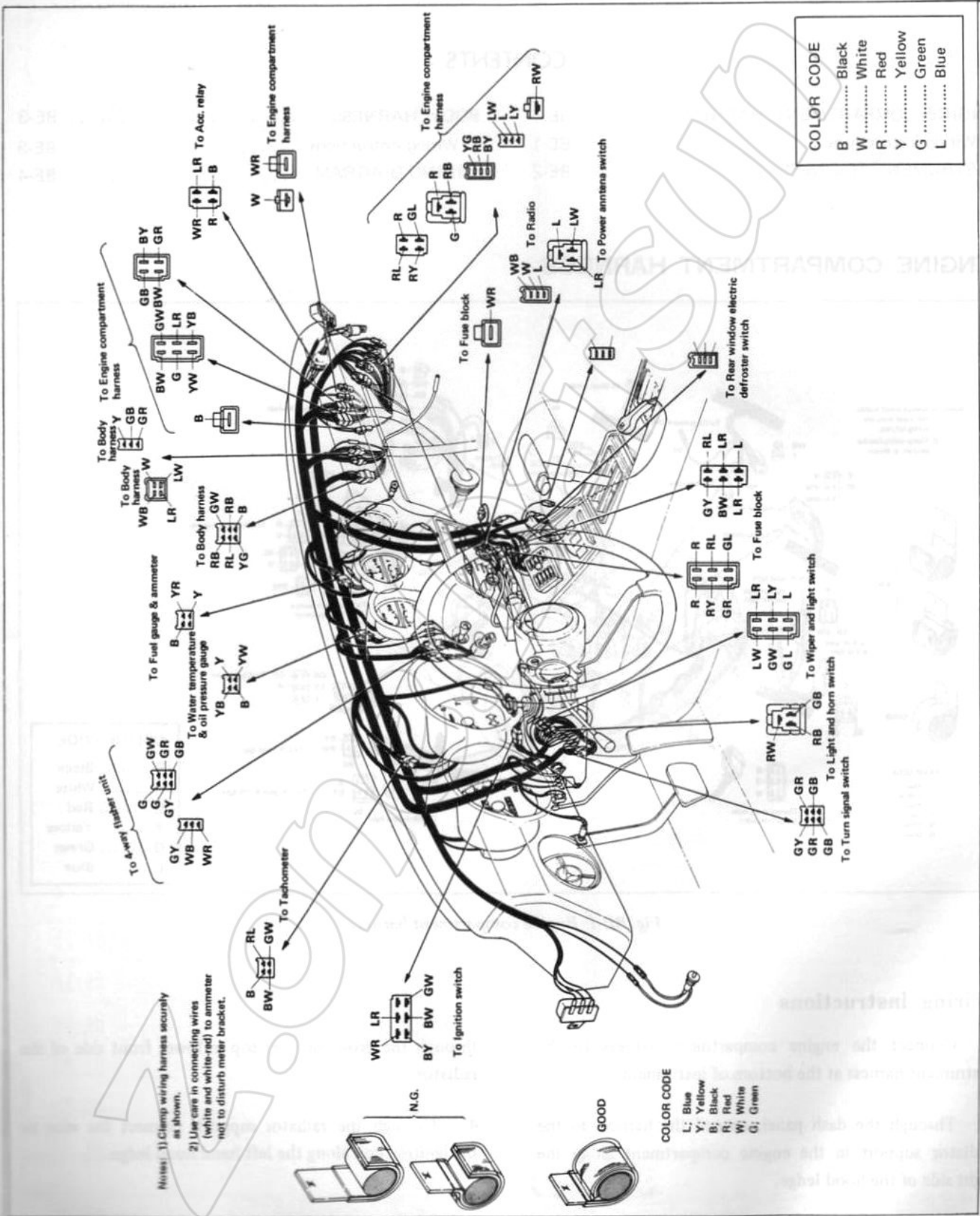

Fig. BE-1 Engine compartment harness

Wiring instructions

1. Connect the engine compartment harness to the instrument harness at the bottom of instrument.
2. Through the dash panel, extend the harness to the radiator support in the engine compartment along the right side of the hood ledge.
3. Extend the harness to the left side of the body through the cross member top in lower front side of the radiator.
4. Through the radiator support, connect the wire to the ignition coil along the left hand hood ledge.

INSTRUMENT HARNESS



BODY ELECTRICAL

BODY HARNESS

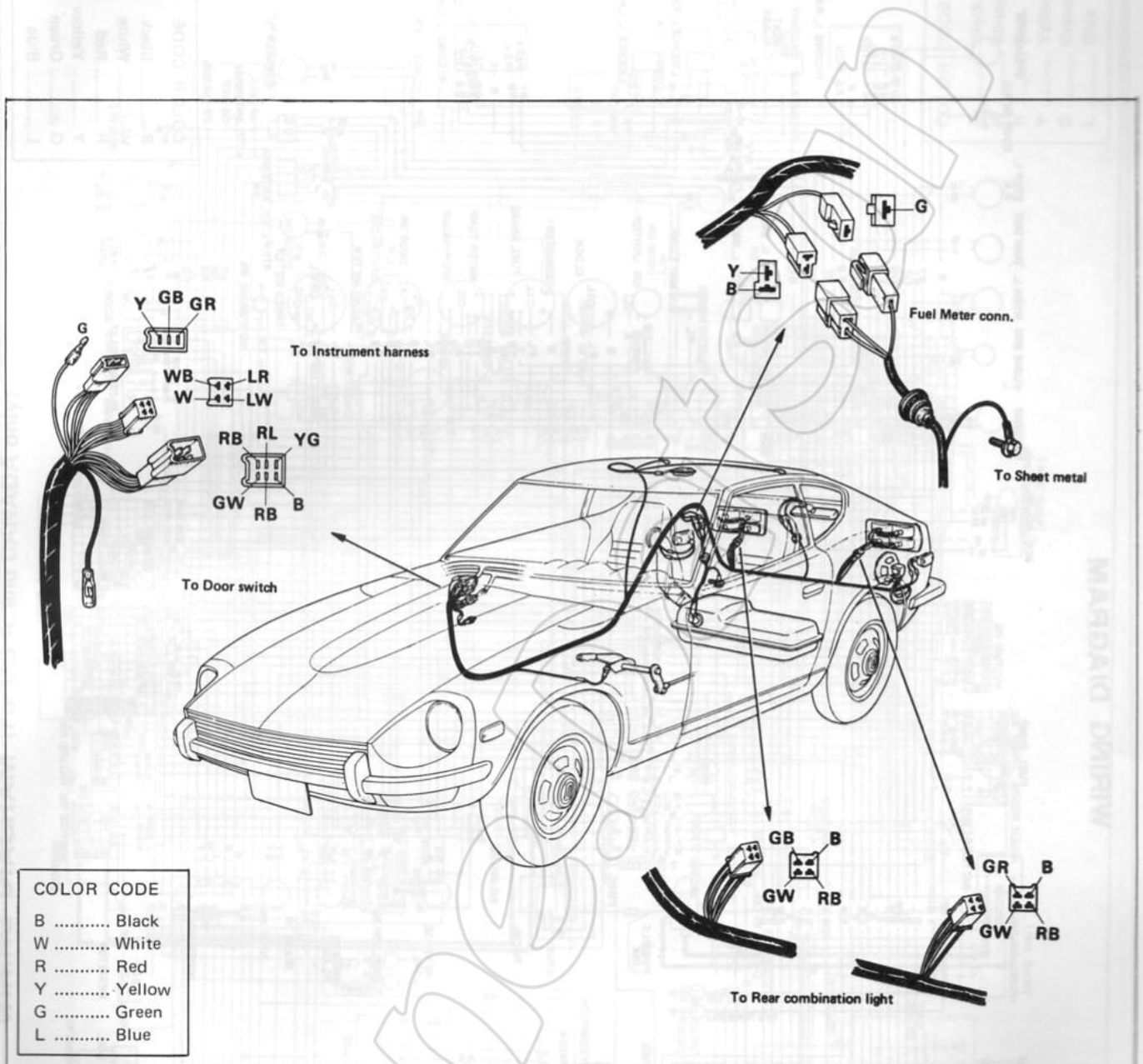
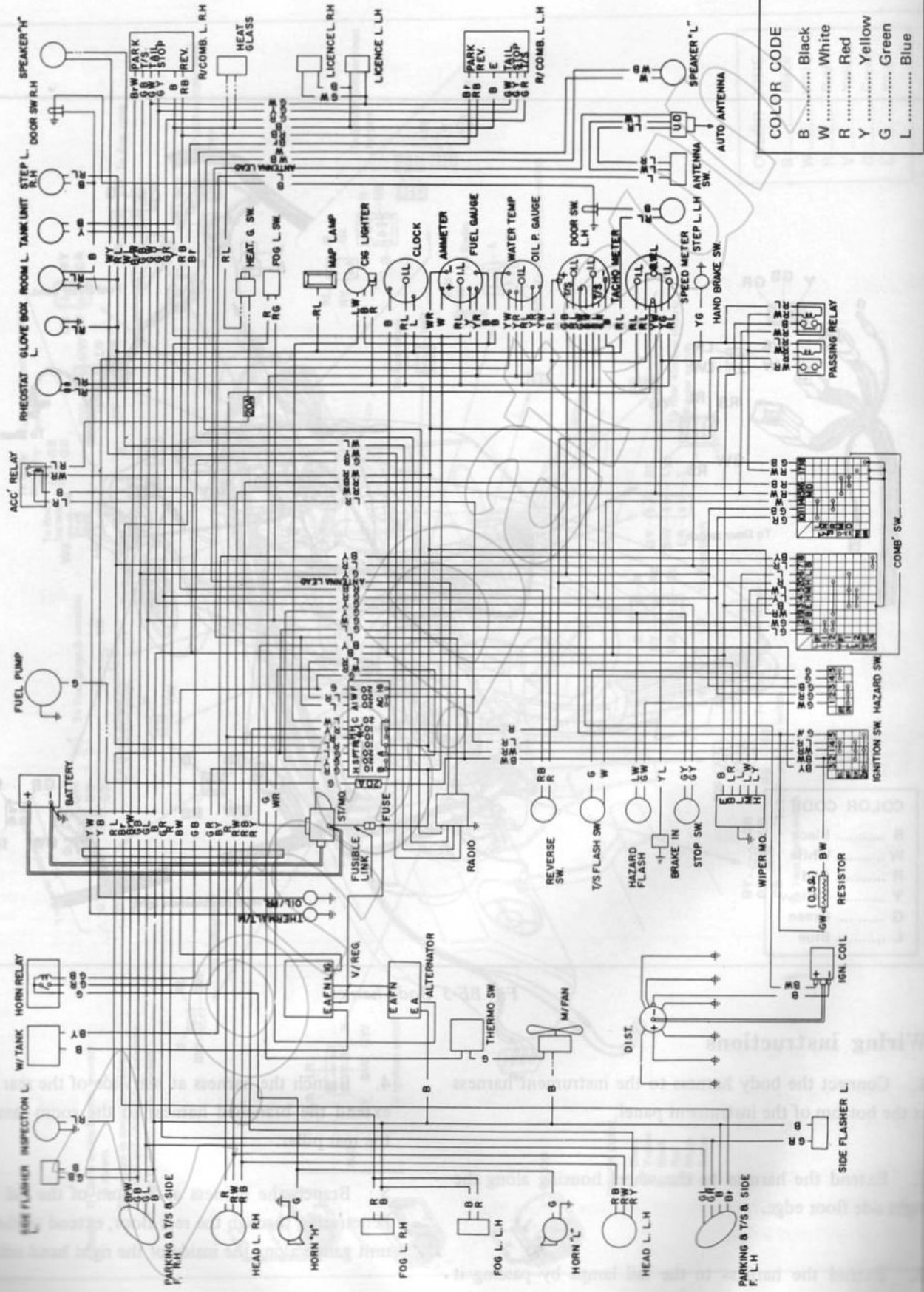

Fig. BE-3 Body harness

Wiring instructions

1. Connect the body harness to the instrument harness at the bottom of the instrument panel.
2. Extend the harness to the wheel housing along the right side floor edge.
3. Extend the harness to the tail lamps by passing it between the inner panel and outer panel.
4. Branch the harness at rear side of the rear pillar, and extend the branched harness to the room lamp through the rear pillar.
5. Branch the harness at bottom of the tail lamp, and penetrating through the rear floor, extend to the fuel tank unit gauge along the inside of the right hand side member.

WIRING DIAGRAM



BODY ELECTRICAL

WIRING DIAGRAM (For U.S.A. and CANADA only)

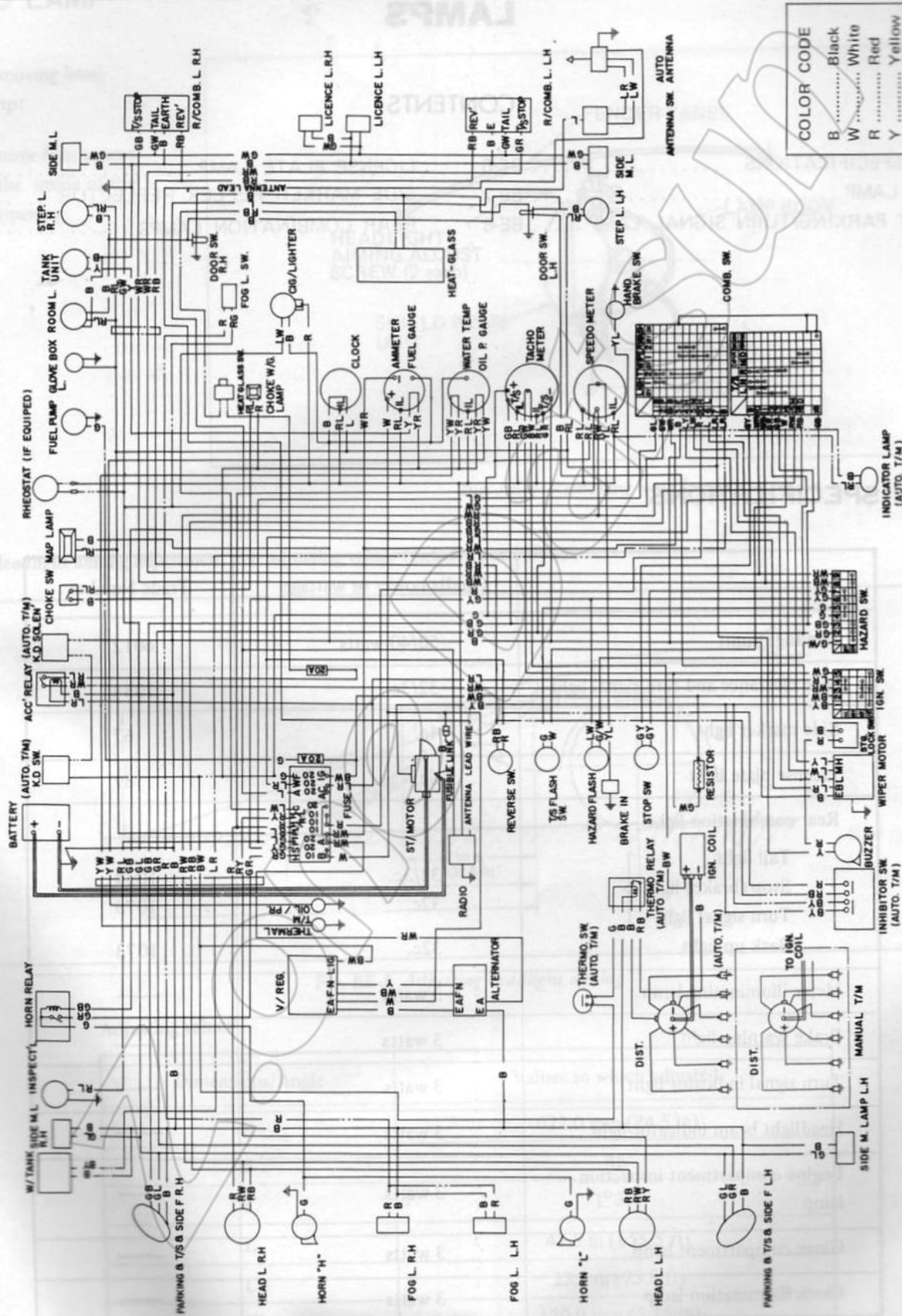

COLOR CODE

B	Black
W	White
R	Red
Y	Yellow
G	Green
L	Blue

BODY

LAMPS

CONTENTS

BULB SPECIFICATIONS	BE-6	LICENSE PLATE LAMP	BE-8
HEAD LAMP	BE-7	SIDE MARKER REFLEX REFLECTOR	BE-8
FRONT PARKING/TURN SIGNAL LAMP	BE-8	REAR COMBINATION LAMPS	BE-8

BULB SPECIFICATIONS

	Candla power or wattage	Trade Number
Headlight unit	50/40 watts	6012
Side clearance and turn signal light	32/3c.	1034
Side marker light	4c.	67
License plate light	6c.	89
Rear combination light		
Tail light	32/3c.	1034
Stop (brake) light	32c.	1073
Turn signal light		
Back up light	32c.	1073
Meter illuminating lamp	3 watts	—
Brake warning light	3 watts	—
Turn signal indicator light	3 watts	—
Headlight beam indicator light	3 watts	—
Engine compartment inspection lamp	3 watts	—
Glove compartment lamp	3 watts	—
Clock illumination lamp	3 watts	—

BODY ELECTRICAL

HEAD LAMP

1. Removing head lamp:

Remove four screws from the inside of the wheel opening.

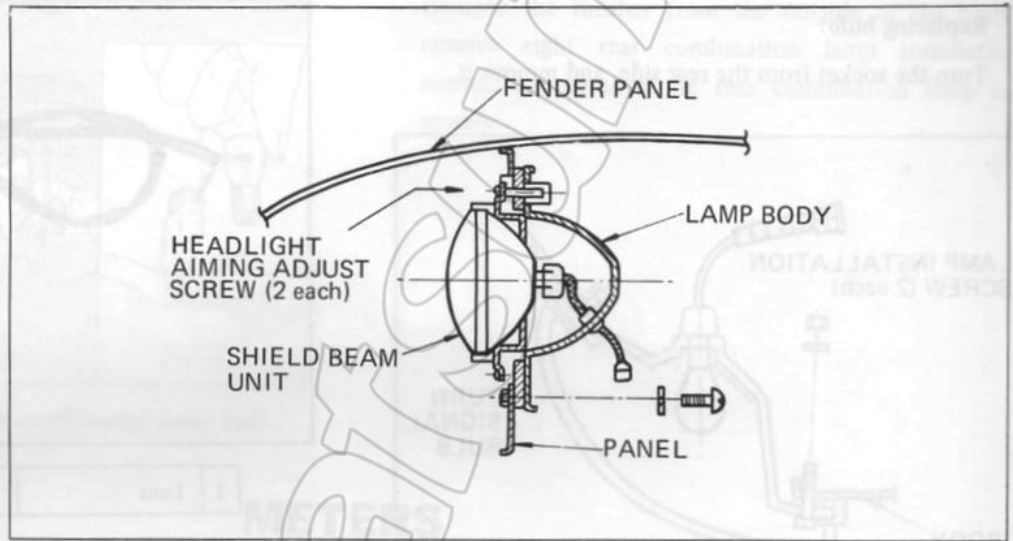

Fig. BE-4 Removing head lamp

2. Headlight aiming adjustment and adjusting values (unladen condition)

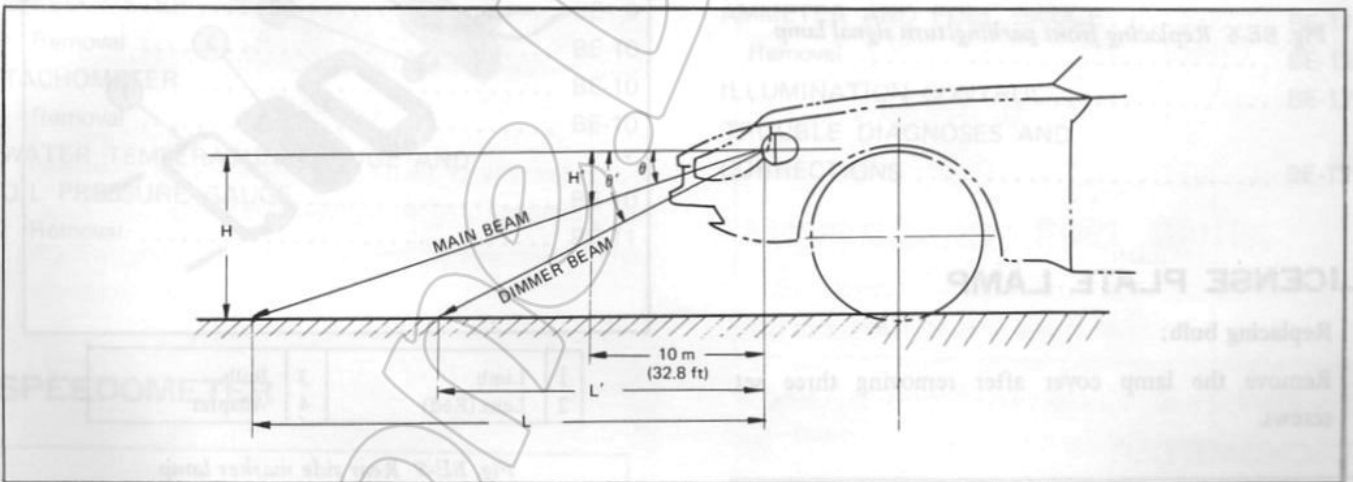

Fig. BE-5 Adjusting headlight aiming

Adjusting values

Dimensions/Angle	Values to which adjusted
H	622.0 mm (24.5 in)
θ	45'
θ'	1°35'
L	47.5 m (155.5 ft)
L'	22.5 m (73.8 ft)
H'	130.9 mm (5.15 in)

BODY

FRONT PARKING / TURN SIGNAL LAMP

Replacing bulb:

Turn the socket from the rear side, and remove it.

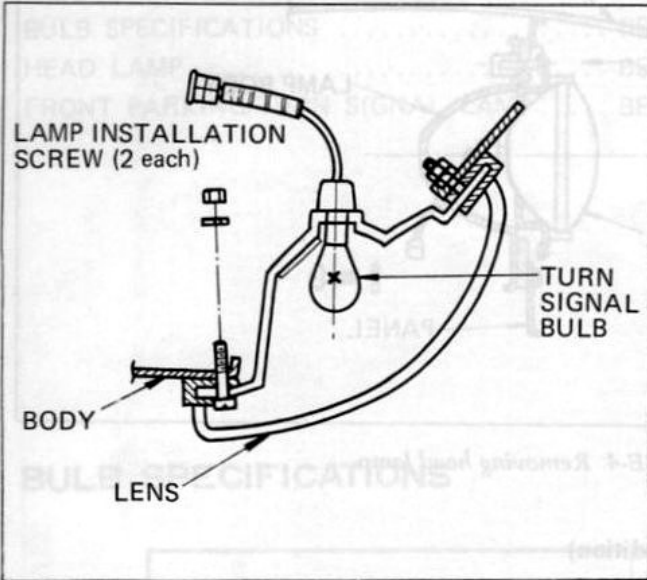
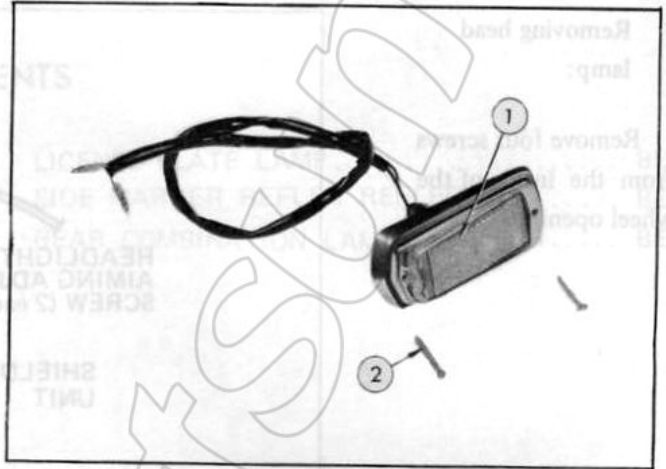

Fig. BE-6 Replacing front parking/turn signal lamp

SIDE MARKER REFLEX REFLECTOR



1	Lens	2	Set screw
---	------	---	-----------

Fig. BE-8 Front side marker lamp

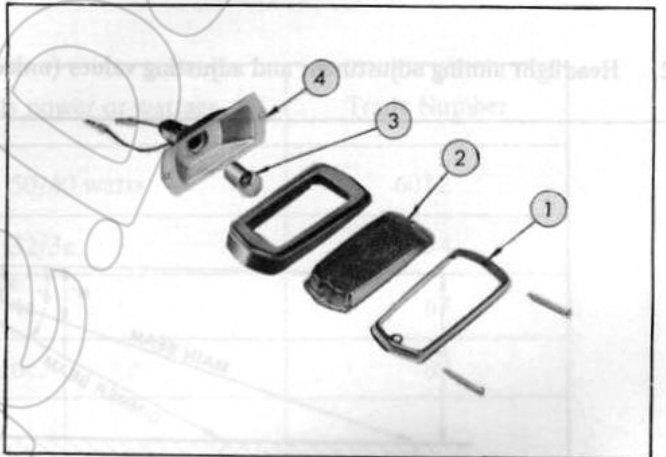

1	Limb	3	Bulb Adapter
2	Lens (Red)	4	Bulb

Fig. BE-9 Rear side marker lamp

LICENSE PLATE LAMP

Replacing bulb:

Remove the lamp cover after removing three set screws.

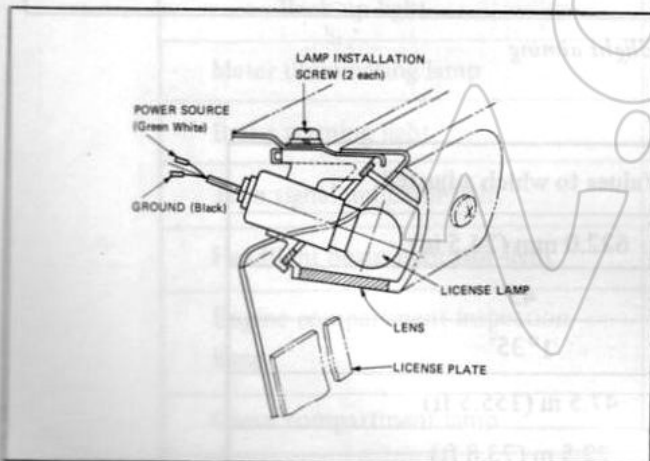

Fig. BE-7 License plate lamp installation

REAR COMBINATION LAMPS

Replacing bulb

Remove the trim cover (four screws) from inside luggage, replace the bulb from the rear side of the socket.

BODY ELECTRICAL

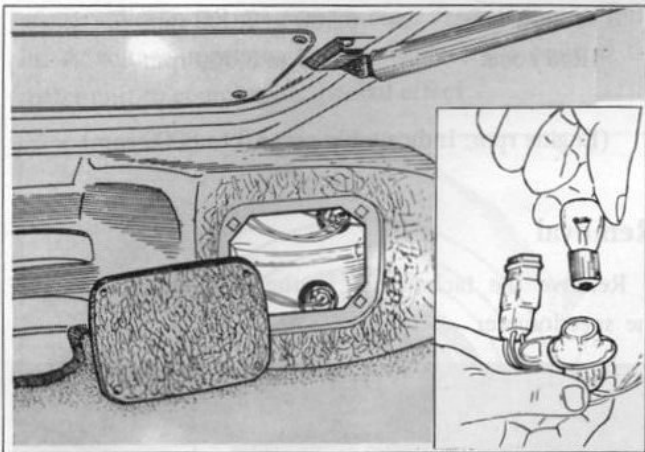

Fig. BE-10 Replacing rear combination lamp bulb

Replacing the rear combination lamp assembly

Remove the finisher from the outside of the body, remove eight rear combination lamp installation screws, and remove the rear combination lamp assembly.

METERS

CONTENTS

SPEEDOMETER	BE-9	AMMETER AND FUEL GAUGE	BE-11
Removal	BE-10	Removal	BE-12
TACHOMETER	BE-10	ILLUMINATION CONTROL	BE-12
Removal	BE-10	TROUBLE DIAGNOSES AND	
WATER TEMPERATURE GAUGE AND		CORRECTIONS	BE-13
OIL PRESSURE GAUGE	BE-10		
Removal	BE-11		

SPEEDOMETER

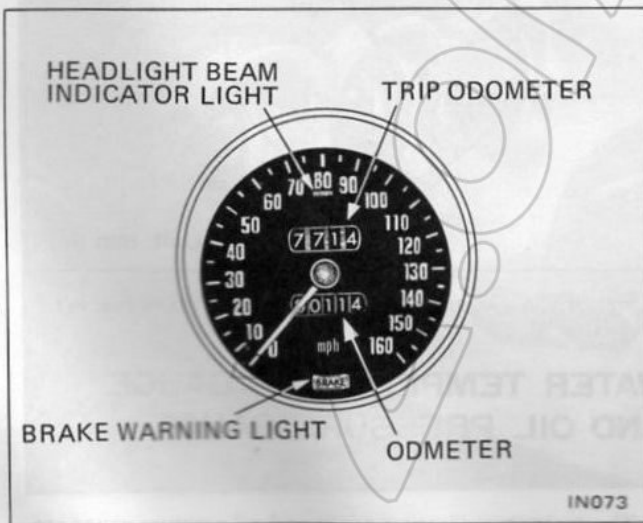

Fig. BE-11 Speedometer

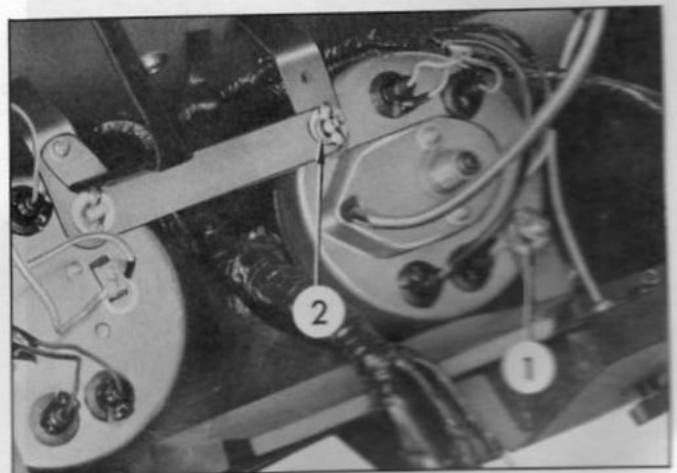

Fig. BE-12 Removing speedometer

Removal

Loosen the wing nuts on the meter brackets [① and ② in Figure BE-12] on the upper and lower sides of the reverse side of the speedometer, and withdraw the speedometer from the instrument panel.

- Note:** a. When loosening the wing nuts, use a pair of pliers.
 b. In order to facilitate the operation, remove the heater air duct.
 c. See Figure BE-15 for details of the speedometer support bracket and mounting bracket.

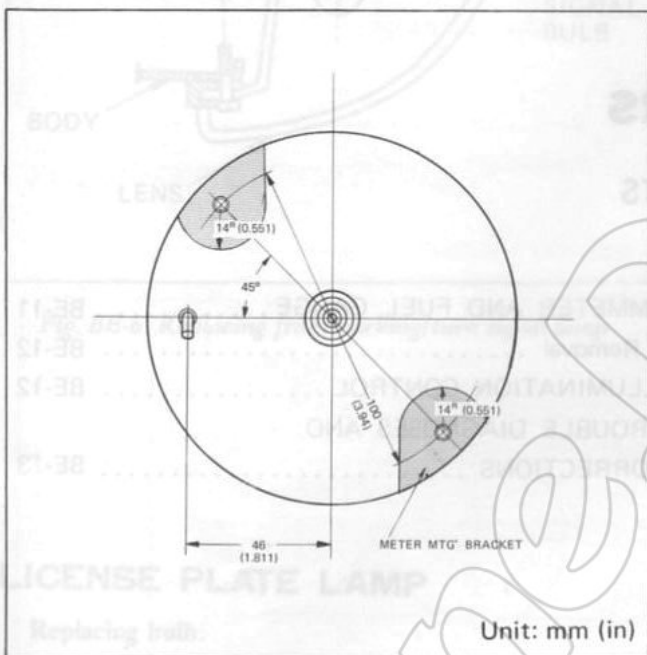

Fig. BE-13 Details of speedometer installation brackets

TACHOMETER



Fig. BE-14 Tachometer

- Yellow zone: 6,500 to 7,000 rpm
- Red zone: 7,000 to 8,000 rpm

(Engine rpm: Indicated in range 0 to 8000 rpm)

Removal

Remove the tachometer in the same manner as for the speedometer.

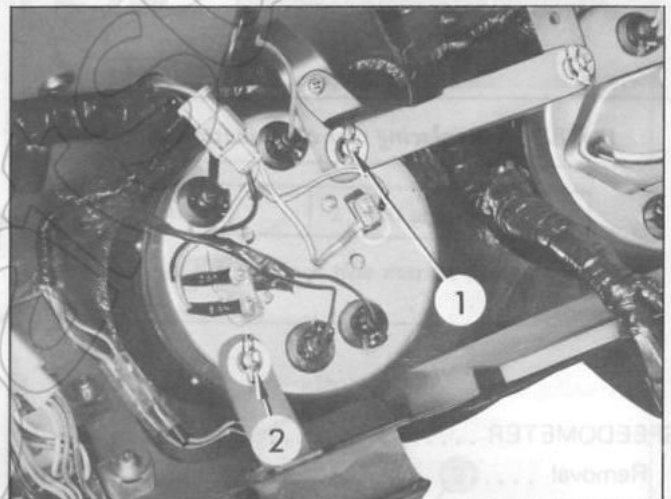

Fig. BE-15

Note: See Figure BE-17 for details of the tachometer support bracket and mounting bracket.

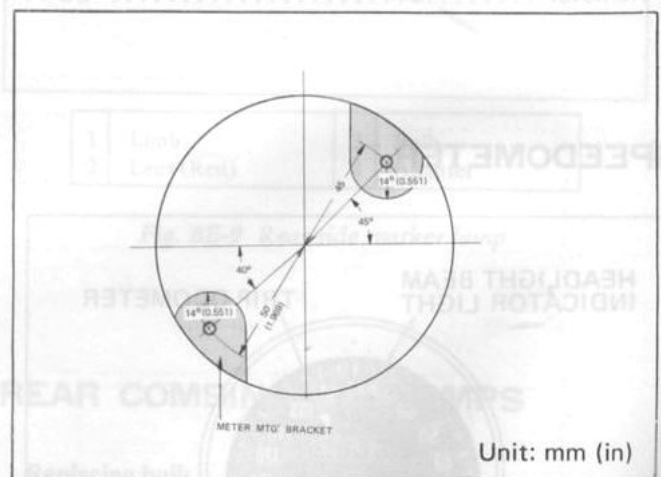

Fig. BE-16 Details of tachometer installation brackets

WATER TEMPERATURE GAUGE AND OIL PRESSURE GAUGE

The water temperature gauge and oil pressure gauge are combined. The water temperature gauge indicates water

BODY ELECTRICAL

temperature in range from 120 to 250°F, and oil pressure gauge indicates oil pressure in range from 0 to 140 lb/sq in. A voltage regulator (meter regulator) is built in the meter unit to compensate thermal effect.

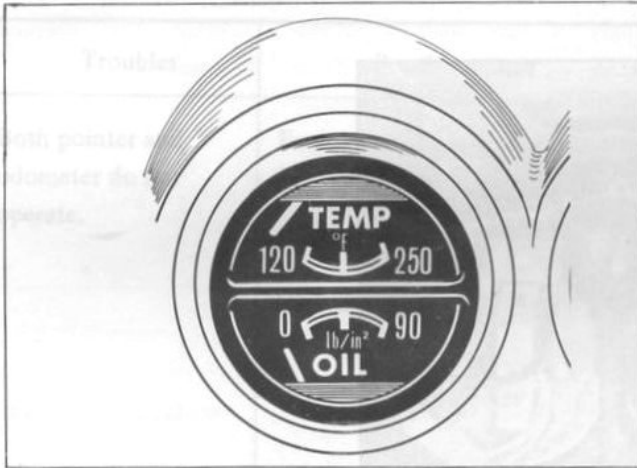

Fig. BE-17 Water temperature gauge and oil pressure gauge



Fig. BE-19 Removing water temperature gauge and oil pressure gauge

Removal

1. Remove the center console finisher.
2. Inserting hand into the opening where the center console finisher has been removed, loosen hexagonal cross-headed screws [① and ② in Figure BE-21] use pair of pliers, and remove the unit from the reverse side of the instrument panel.

Note: When loosening the installation screws, use a pair of pliers.

AMMETER AND FUEL GAUGE

The ammeter and fuel gauge are combined to a single unit. The ammeter indicates in range from -45 to +45A. "E" and "F" marks on the fuel gauge represent respectively "Empty" [5 liters (18.9 US gal, 122.7 Imp gal)] and "Full" [60 liters (227 US gal, 273 Imp gal)].

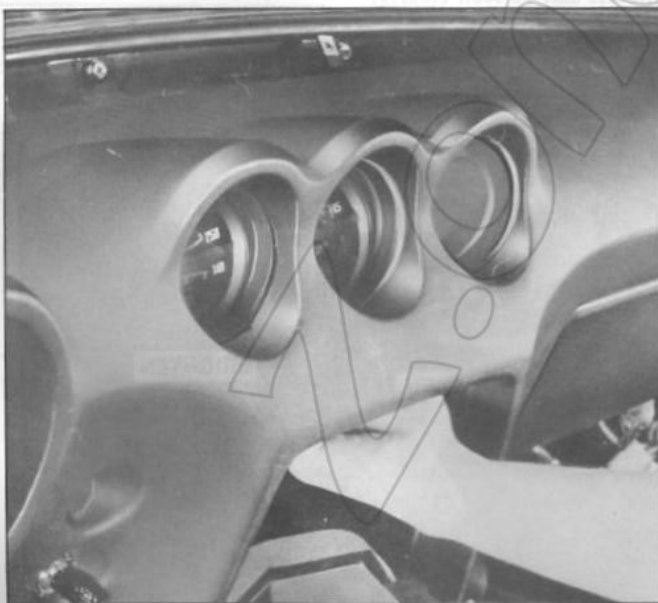

Fig. BE-18 Removing center console finisher



Fig. BE-20 Ammeter and fuel gauge

Removal

Remove the ammeter and fuel gauge unit in the same manner as for the oil pressure gauge and water temperature gauge. To be more specifically, when removing the

ammeter and fuel gauge unit, remove the meter bracket, and remove hexagonal cross-headed screws [① and ② in Figure BE-23] from reverse side of the meter.

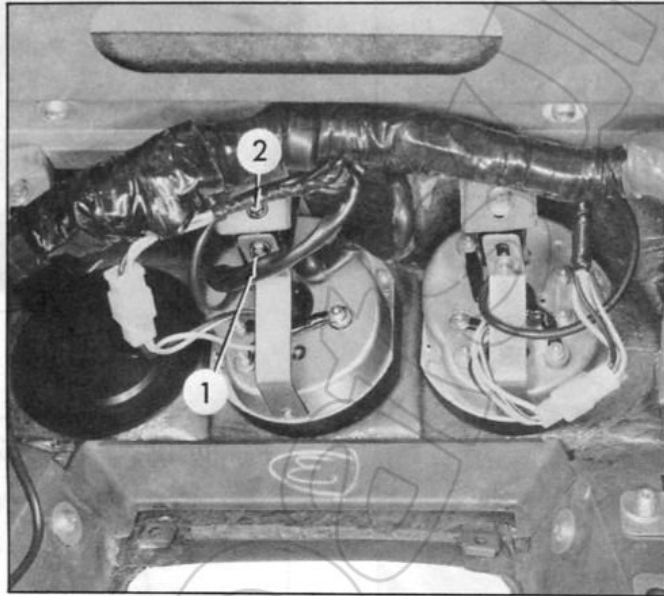

Fig. BE-21 Removing ammeter and fuel gauge

ILLUMINATION CONTROL

The illumination control is a variable resistor

(Rheostat) with which the meter illumination can be controlled (none step) to get proper brightness so that the meters can be seen clearly.

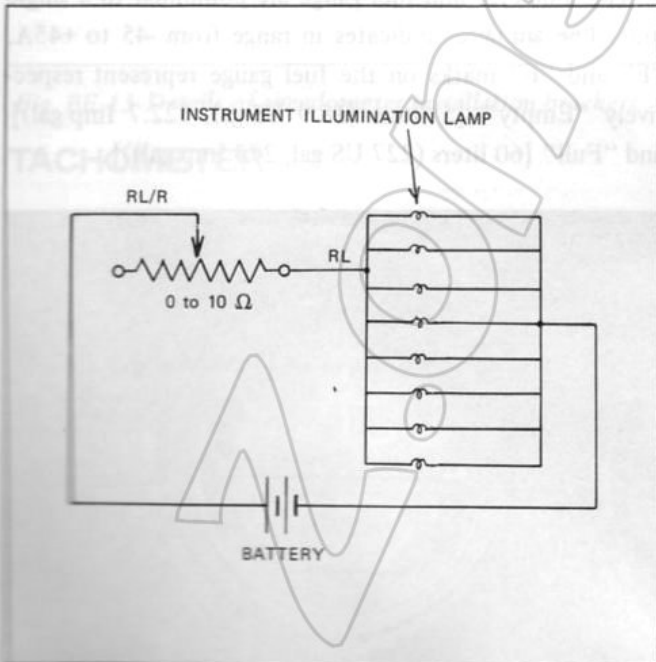

Fig. BE-22 Circuit diagram of illumination control

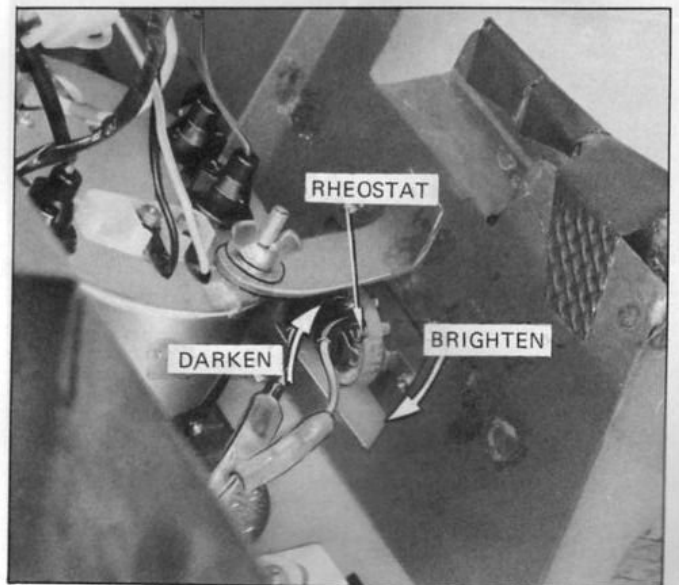

Fig. BE-23 Removing illumination control

BODY ELECTRICAL

TROUBLE DIAGNOSES AND CORRECTIONS

Speedometer			
Troubles	Possible causes	Method of inspection	Corrective action
Both pointer and odometer do not operate.	Faulty speedometer cable union nut tightening	Check the union nut for tightness.	Retighten the union nut.
	Broken speedometer cable	Check the speedometer cable.	Replace the cable
	Damaged speedometer drive gear	Check the drive gear	Replace the drive gear and pinion assembly.
	Defective speedometer	Remove the speedometer unit, and check.	Replace the meter unit.
Pointer deflects excessively.	Rusted cable	Make sure that the cable is rusted.	Replace the cable.
	Improperly installed speedometer cable (bent excessively)	Check the cable for installing condition.	Correct bending radius to more than 100 mm (3.9 in).
	Broken speedometer cable	Check the cable for condition.	Replace the cable.
	Damaged speedometer drive gear	Check the drive gear.	Replace the drive gear/pinion assembly.
Pointer unstable.	Defective speedometer	Remove the speedometer unit, and check.	Check and replace if required.
	Improperly tightened speedometer union nut	Check the union nut for tightening condition.	Retighten or repair if required.
	Defective speedometer cable	Check the speedometer cable.	Replace cable.
	Damaged speedometer drive gear	Check the drive gear.	Replace speedometer unit.
Unusual noise	Defective speedometer	Remove and check the speedometer unit.	
	Excessively bent speedometer cable, lack of lubricant, or twisted speedometer cable.	Check the cable for excessive bending.	Replace the cable.
			Replace the meter.

Water temperature gauge

Even the switch is turned on, the pointer does not operate.	Blown off fuse	Check the fuse.	Replace if blown off.
	Defective thermal transmitter	Apply a test lamp (approximately 12V-3W) using DC12V in series to the lead wire yellow/white) which connected to the thermal transmitter, and ground another wire from the test lamp. Then pointer deflects.	Replace the thermal transmitter.
	Defective meter unit or faulty wiring	When above described inspection is conducted and the pointer still does not operate, remove the meter unit, connect the unit with a test lamp (12V-3W) in series, and apply DC12V. <ul style="list-style-type: none"> o If the pointer deflects; o If the pointer does not deflect; 	Repair the wiring. Replace the meter unit.

Fuel gauge

When the source switch is closed, the pointer does not operate.	Blown off fuse	Defective tank unit grounding	Replace if blown off.
	Defective tank unit grounding	Apply a test lamp (12V-3W) using DC12V to the tank unit lead wire in series and ground the tank, then pointer deflects.	
	Defective meter unit or wiring	When above described inspection is conducted and the meter pointer does not deflect, remove the meter unit, apply a test lamp (12V-3W) to the unit in series, and apply DC12V. <ul style="list-style-type: none"> o The pointer deflects to "F". o The pointer does not deflect after repairing. 	Correct the wiring. Replace the meter unit.
The pointer indicates a point constantly regardless of actual fuel level.	Defective tank unit	When the lead wire to the tank is disconnected at the tank unit terminal, the pointer returns to "E"	Replace tank unit.

BODY ELECTRICAL

	<p>Defective meter unit or wiring</p>	<p>When the above described inspection is conducted and the pointer of the meter still does not deflect, remove the meter unit, apply a test lamp (12V-3W) to the unit in series, and apply DC12V.</p> <ul style="list-style-type: none"> o The pointer deflects to "F" o The pointer does not deflect. 	<p>Correct the wiring. Replace the meter unit.</p>
-----------------------------------------------------------------------------------	---------------------------------------	---------------------------------------------------------------------------------------------------------------------------------------------------------------------------------------------------------------------------------------------------------------------------------------------------------------------------------	--------------------------------------------------------

Ammeter

Improper indication	Lack of alternator capacity (45A)	Measure the alternator charging voltage	Repair the voltage regulator/alternator.
---------------------	-----------------------------------	-----------------------------------------	------------------------------------------

WINDSHIELD WIPER

CONTENTS

Main specifications	BE-16	Windshield wiper installing position	BE-16
Motor performance	BE-16	Windshield wiper motor connecting diagram	BE-17

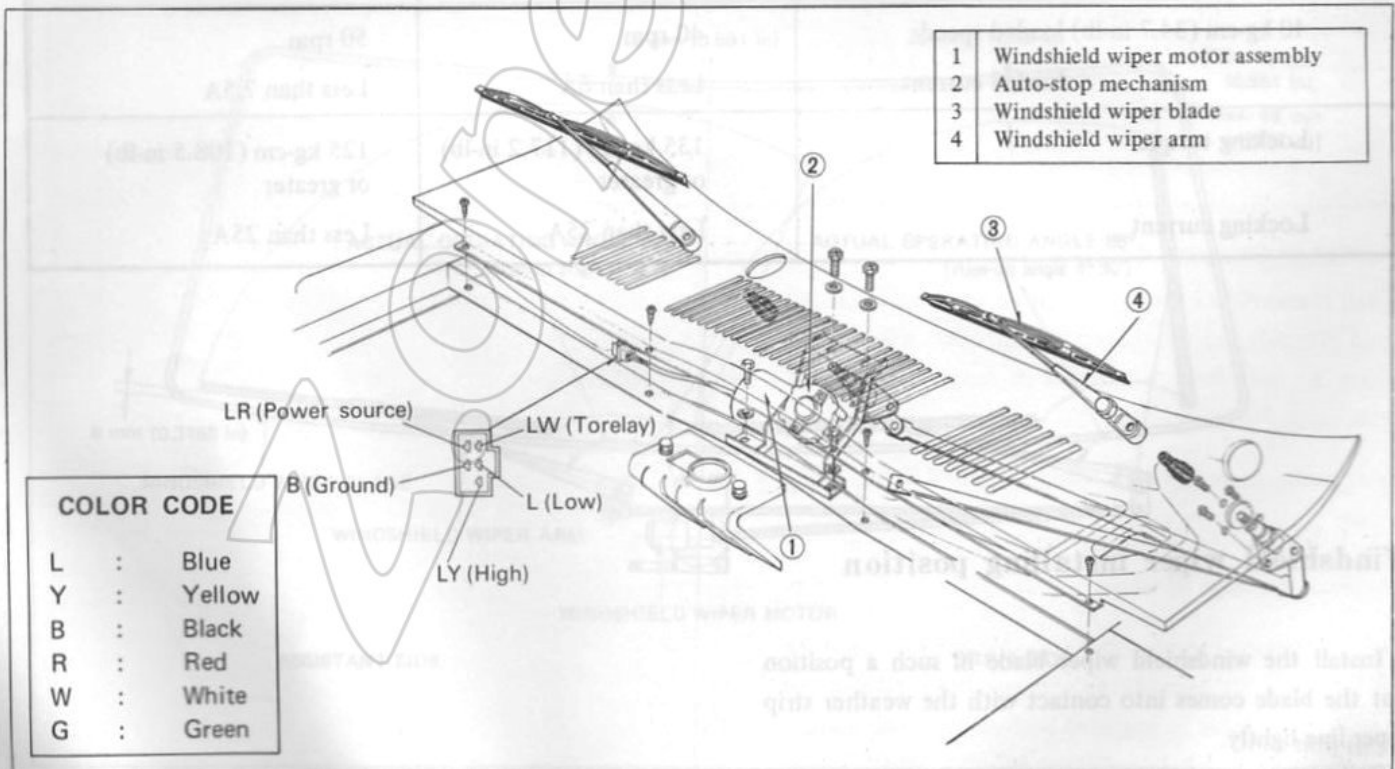
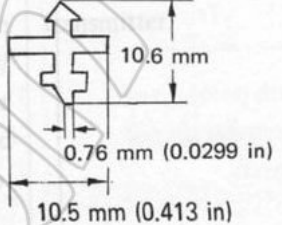

Fig. BE-24 Structure of windshield wiper

BODY

Main specifications

Wiping system	Parallel interlock system (tandem type)		Cross-sectional view of blade rubber: 
Wiping angle	86° (Driver side)	96° (Assistant side)	
Rise-up angle	4°30' (Driver side)	5°30' (Assistant side)	
Blade length	460 mm (18 in)		
Arm installation method	Tapered serration		

Motor performance

Item	Specification	
	LOW	HIGH
Rated voltage	12V	
Test voltage	13.5V	
Starting voltage	Less than 8V	
Unloaded speed	56 rpm	78 rpm
Unloaded current	Less than 2.5A	Less than 2.5A
10 kg-cm (8.7 in-lb) loaded speed	52 rpm	75 rpm
loaded current	Less than 3A	Less than 3.5A
40 kg-cm (34.7 in-lb) loaded speed	40 rpm	50 rpm
loaded current	Less than 6A	Less than 7.5A
Locking torque	135 kg-cm (117.2 in-lb) or greater	125 kg-cm (108.5 in-lb) or greater
Locking current	Less than 25A	Less than 25A

Windshield wiper installing position

Install the windshield wiper blade in such a position that the blade comes into contact with the weather strip upper line lightly.

Tighten the windshield wiper blade arm lock nut under 80 to 100 kg-cm (70 to 87 in-lb) tightening torque.

BODY ELECTRICAL

Windshield wiper motor connecting diagram

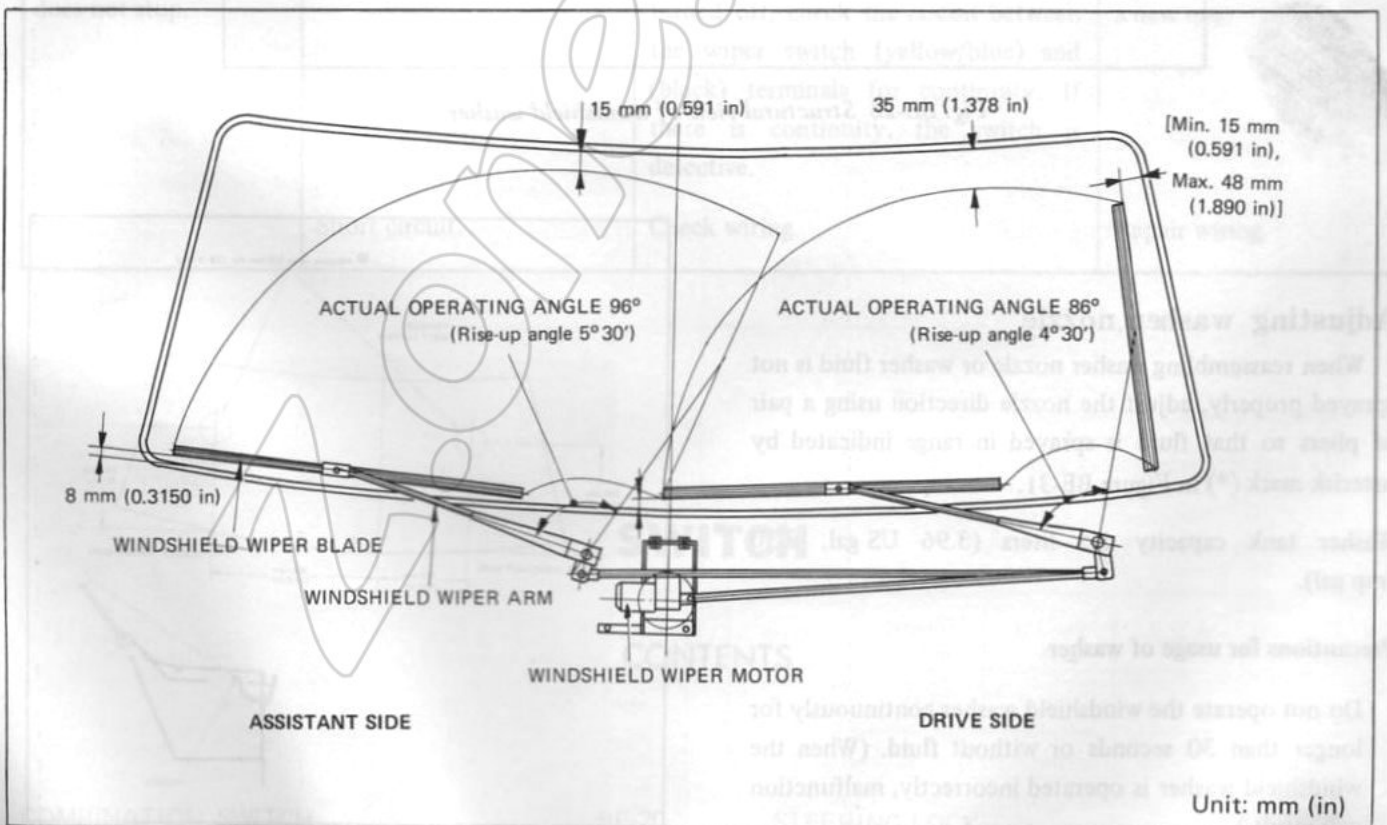
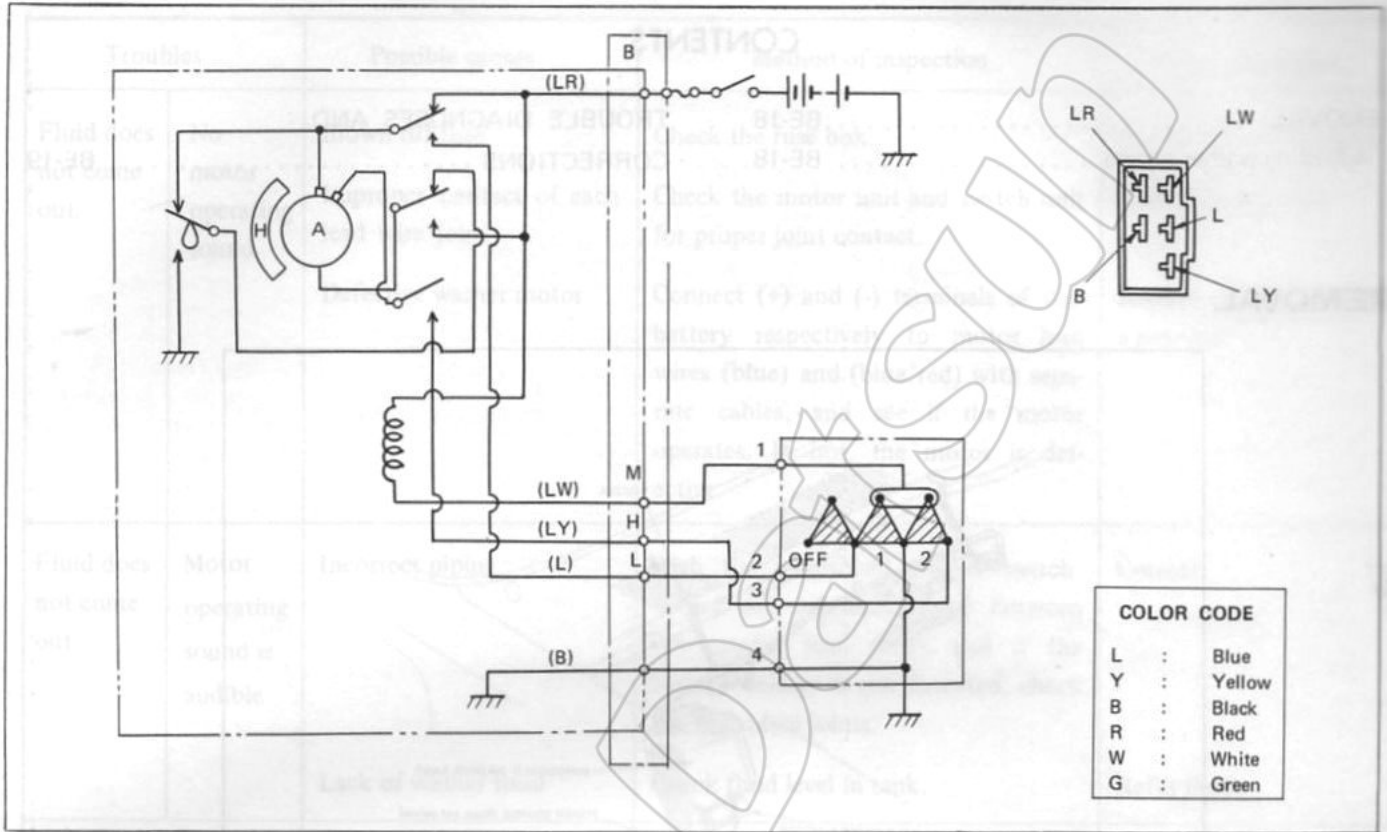

Fig. BE-25 Wiper blade operating range

WINDSHIELD WASHER

CONTENTS

REMOVAL	BE-18	TROUBLE DIAGNOSES AND	
Adjusting washer nozzle	BE-18	CORRECTIONS	BE-19

REMOVAL

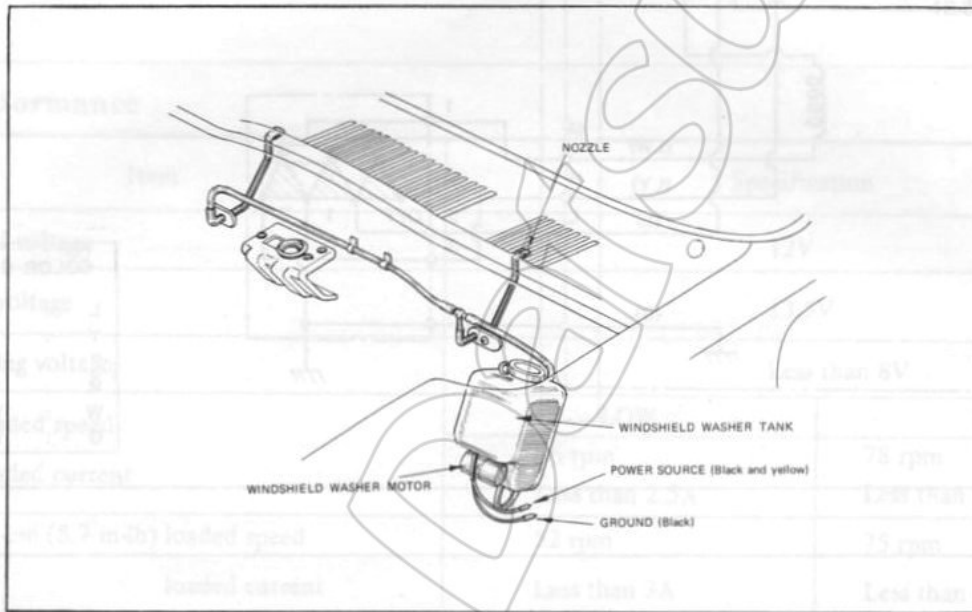

Fig. BE-26 Structural view of windshield washer

Adjusting washer nozzle

When reassembling washer nozzle or washer fluid is not sprayed properly, adjust the nozzle direction using a pair of pliers so that fluid is sprayed in range indicated by asterisk mark (*) in Figure BE-31.

Washer tank capacity 1.5 liters (3.96 US gal, 3.30 Imp gal).

Precautions for usage of washer

Do not operate the windshield washer continuously for longer than 30 seconds or without fluid. (When the windshield washer is operated incorrectly, malfunction will result.)

Ordinarily, limit operating time within 10 seconds.

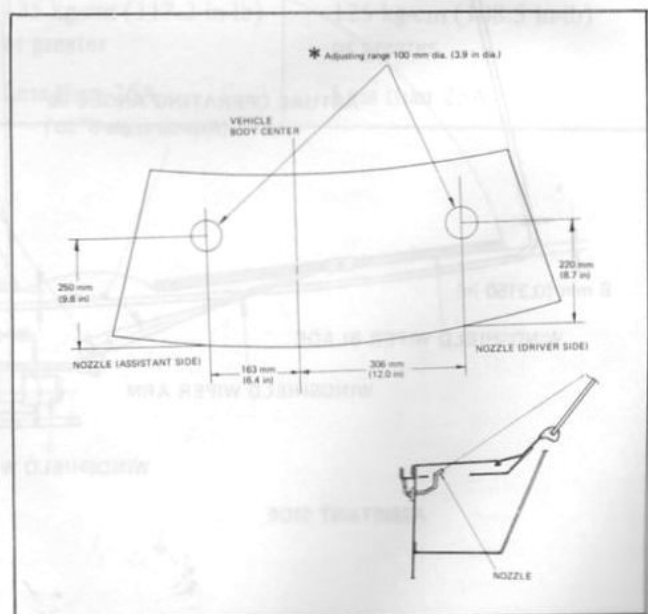

Fig. BE-27 Adjusting washer nozzle

BODY ELECTRICAL

TROUBLE DIAGNOSES AND CORRECTIONS

Troubles		Possible causes	Method of inspection	Corrective action
Fluid does not come out.	No motor operating sound	Blown off fuse	Check the fuse box.	Replace fuse if required.
		Improper contact of each lead wire joint	Check the motor unit and switch unit for proper joint contact.	Correct if required.
		Defective washer motor	Connect (+) and (-) terminals of the battery respectively to motor lead wires (blue) and (blue/red) with separate cables, and see if the motor operates. If not, the motor is defective.	Replace the motor with a new one.
Fluid does not come out.	Motor operating sound is audible	Incorrect piping	With the windshield washer switch turned on, measure voltage between two motor lead wires, and if the battery voltage is not detected, check the individual joints.	Correct.
		Lack of washer fluid	Check fluid level in tank.	Refill fluid.
The windshield washer does not stop.		Defective switch.	With the windshield washer switch turned off, check the circuit between the wiper switch (yellow/blue) and (black) terminals for continuity. If there is continuity, the switch is defective.	Replace the switch with a new one.
		Short circuit.	Check wiring.	Repair wiring.

SWITCH

CONTENTS

COMBINATION SWITCH
HAZARD SWITCH

BE-20
BE-21

STEERING LOCK BE-21
WARNING BUZZER BE-22

COMBINATION SWITCH

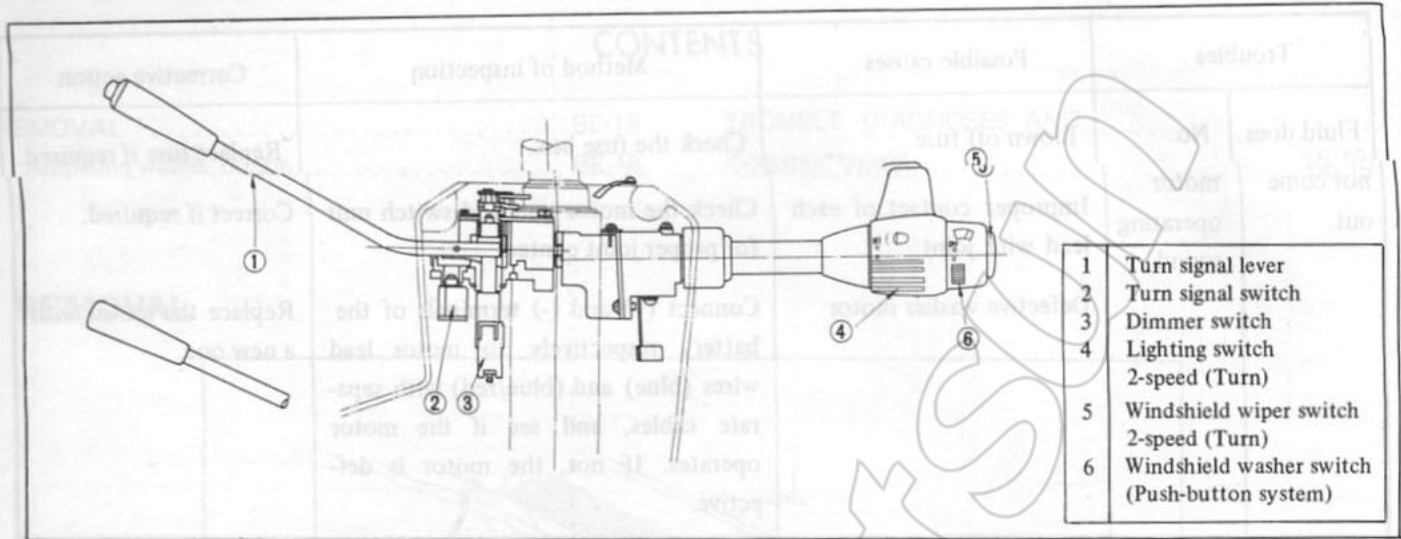

- 1 Turn signal lever
- 2 Turn signal switch
- 3 Dimmer switch
- 4 Lighting switch
- 5 Windshield wiper switch
- 6 Windshield washer switch (Push-button system)

Fig. BE-28 Structural view of combination switch

The combination switch is split into two compartments; one consists of lighting switch, wiper switch,

and windshield washer switch, and the other consists of turn signal switch and dimmer switch.

Each switch operating force

Turn signal switch	0.2 to 0.6 kg (0.44 to 1.32 lb)
Dimmer switch	0.3 to 0.8 kg (0.66 to 1.76 lb)
Windshield wiper switch	1 to 3.3 kg (2.2 to 7.3 lb)
Passing switch	0.2 to 0.6 kg (0.44 to 1.32 lb)
Lighting switch	0.2 to 0.6 kg (0.44 to 1.32 lb)
Windshield washer switch	0.7 to 1.3 kg (1.54 to 2.87 lb)

Combination switch connection circuit

(1) Lighting/windshield wiper switch side

Conjunction table of Lighting Switch:

Terminal Lever position	Battery	parking lamp	Dimmer switch	Earth
OFF				
First step	6.1A			
Second step	6.1A		9.2A	

Conjunction of Wiper Switch:

Terminal Lever position	High	Low	Medium	Earth
OFF				
First step		5A	5A	
Second step		5A	5A	

Fig. BE-29

BODY ELECTRICAL

(2) Turn signal lever side

Conjunction table of Dimmer Switch:

Terminal Lever position	Earth	Main switch	Dimmer switch
Main switch	○	○ 9.2A	
Dimmer switch	○	○ 9.2A	○

Conjunction table of Turn Signal Switch :

Terminal Lever position	Flasher	Stop switch	Front left	Front right	Rear left	Rear right
Left	○	○ 2.2A	○	○ 5.8A	○ 5.8A	
Neutral		○	○ 5.8A		○ 5.8A	○ 5.8A
Right	○	○	○ 2.2A	○ 5.8A	○	○

Fig. BE-30

HAZARD SWITCH

This switch is a tumbler switch. When removing, remove the installation screw from the switch boss portion.

When removing, use the tumbler switch replacer (special tool ST08900000).

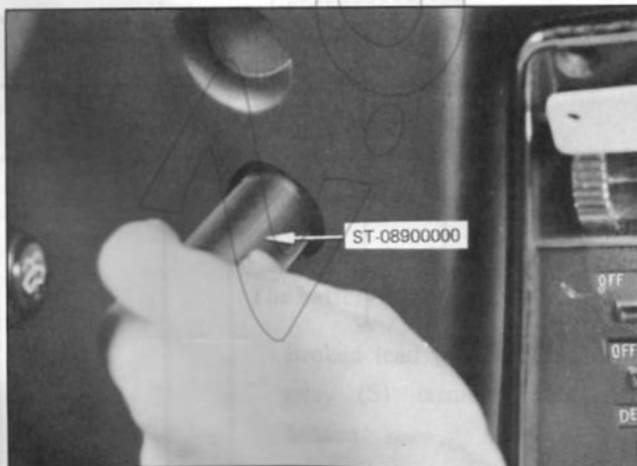

Fig. BE-31

STEERING LOCK

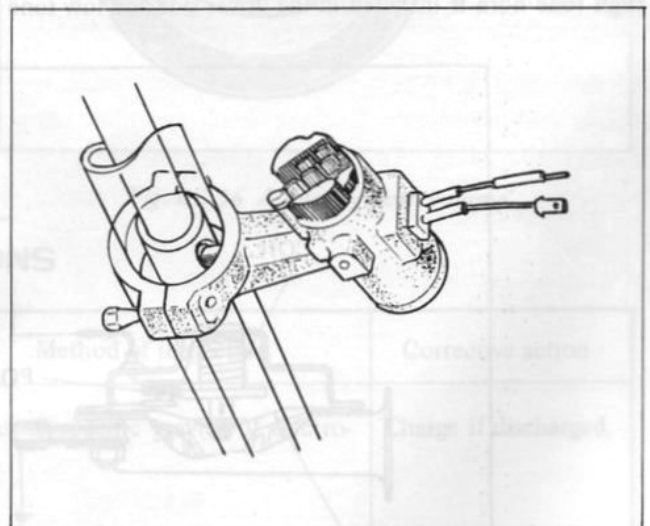

Fig. BE-32 Steering lock

The steering lock is combined with the ignition switch to a single unit which contains warning buzzer micro-switch for reminding the drive to lock the steering. The microswitch is connected to a warning buzzer.

WARNING BUZZER

(It operates if the door is unlocked with the key inserted in the steering lock)

The warning buzzer is installed on the steering support. When removing the warning buzzer, disconnect steering lock side microswitch cables, and remove two warning buzzer installation screws.

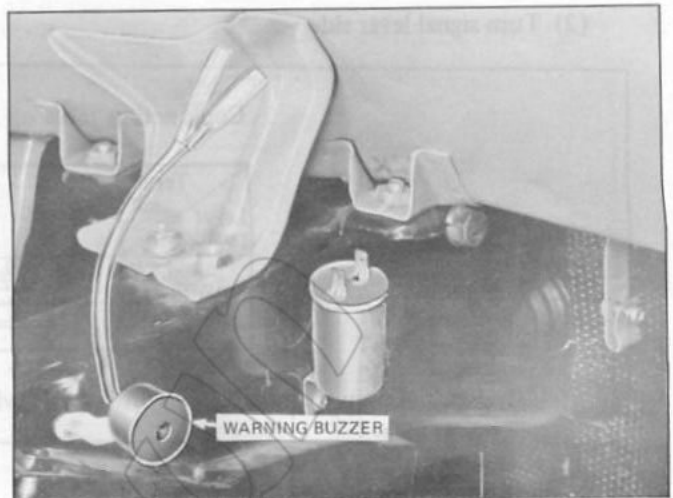

Fig. BE-33 Removing warning buzzer

HORN AND HORN RELAY

CONTENTS

Adjusting horn volume

BE-23

TROUBLE DIAGNOSES AND CORRECTIONS

BE-23

The horn is installed on the top of front crossmember. High tone horn is installed in the driver side and low tone

horn is installed in the assistant side facing toward front. The horn relay is installed on the left side dash side panel.

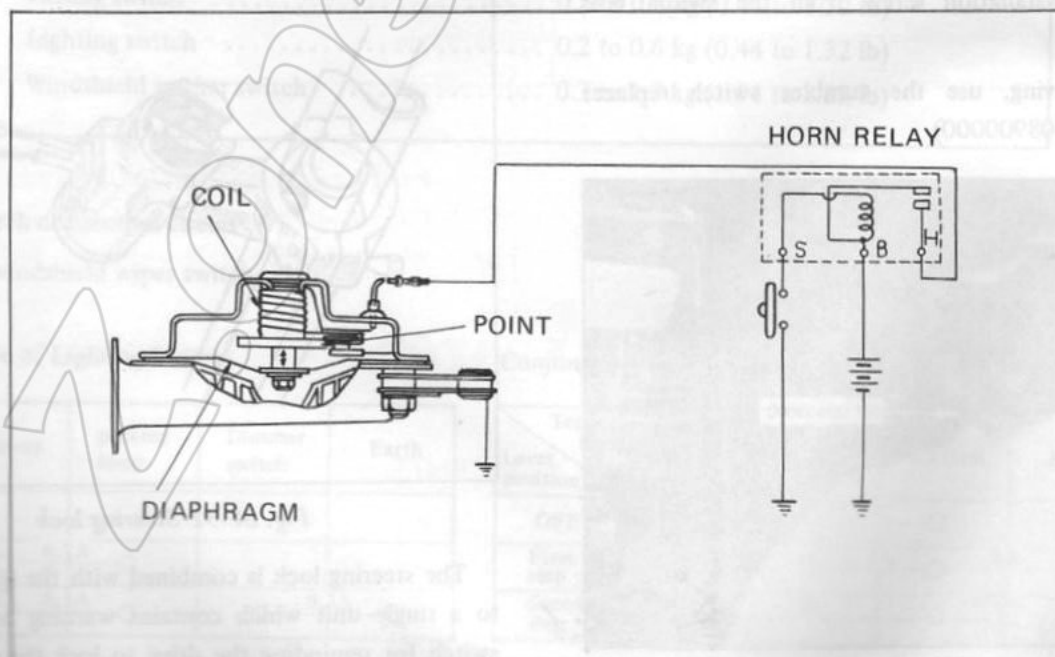

Fig. BE-34 Horn and horn relay circuit diagram

Adjusting horn volume

1. Apply voltage meter and connect cables as shown in Figure BE-39.
2. Turn on the switch, make sure that the voltmeter indicates 12 to 12.5V, and adjust as described below so that the ammeter indicates approximately 3A.
3. Lock nut in reverse side of the body
 - (1) Turn the lock nut in counterclockwiseVolume and current increases.
 - (2) Turn the lock nut in clockwise Volume and current reduces.
4. When a proper volume is obtained through the above described method, raise the voltage to 14 or 15V, and further adjust the volume to better sound.
5. A proper sound obtained at range from 12 to 15V is the best adjusting point.
Lock the nut at that position.

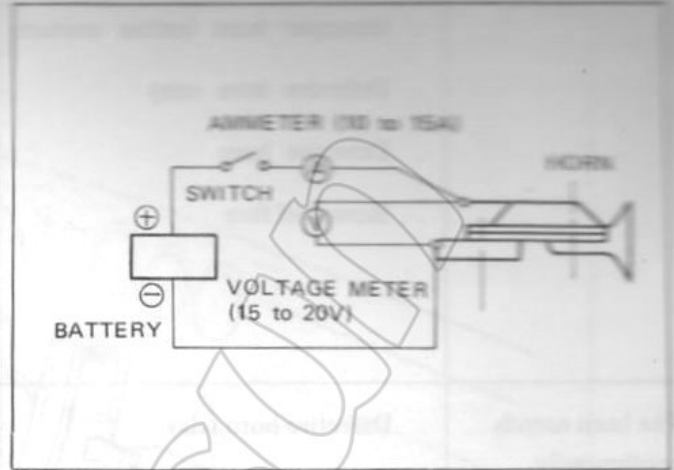

Fig. BE-35 Circuit diagram of horn

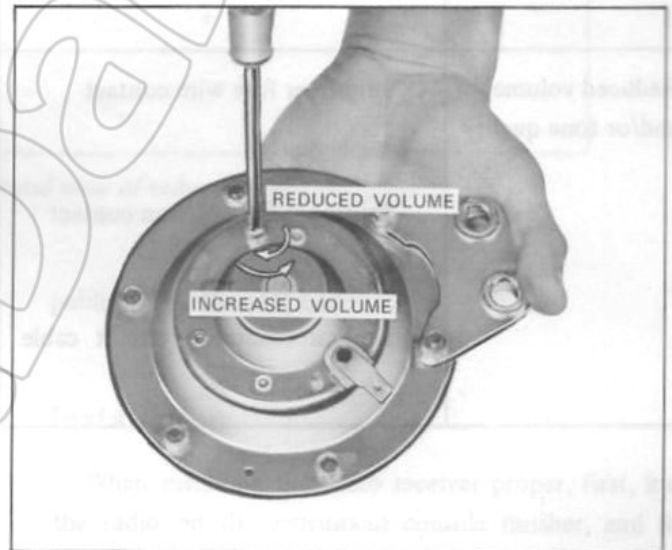

Fig. BE-36 Adjusting horn volume

TROUBLE DIAGNOSES AND CORRECTIONS

Troubles	Possible causes	Method of inspection	Corrective action
The horn does not operate.	Excessively discharged battery The battery is normal. Broken lead wire between horn relay (S) terminal and horn button.	Measure specific gravity of electrolyte. The horn does not sound although the horn relay terminal (S) is grounded, but sounds when the terminals (B) and (H) are short-circuited.	Charge if discharged.

BODY

	<ul style="list-style-type: none"> Improper horn button contact Defective horn relay Defective horn Blown off fuse 	<p>The horn does not sound although the horn relay terminals (B) and (H) are short-circuited, and the horn still does not sound although the battery (+) terminal is connected to the horn terminal directly.</p> <p>When the horn sounds through the above inspection, check the fuse for wear, fusing, or improper contact.</p>	Replace.
The horn sounds continuously.	<ul style="list-style-type: none"> Defective horn relay Short-circuited horn button and horn relay terminal (S). 	<p>The horn does not stop although the horn relay (S) terminal is disconnected.</p> <p>When the horn stops through the above disconnection, check the horn button unit particularly carefully.</p>	<p>Replace horn relay.</p> <p>Replace horn button (Switch).</p>
Reduced volume and/or tone quality	<ul style="list-style-type: none"> Improper fuse wire contact Broken cable Improper horn button contact Worn horn point Broken resistance circuit cable 		<p>Correct.</p> <p>Repair.</p> <p>Repair.</p> <p>Adjust or replace.</p> <p>Replace the resistance with a new one.</p>

RADIO

CONTENTS

Installation	BE-25	Installing antenna	BE-26
Radio specifications	BE-25	Antenna specifications ..	BE-27
Installing speaker	BE-26	Auto-antenna switch circuit	BE-27

BODY ELECTRICAL

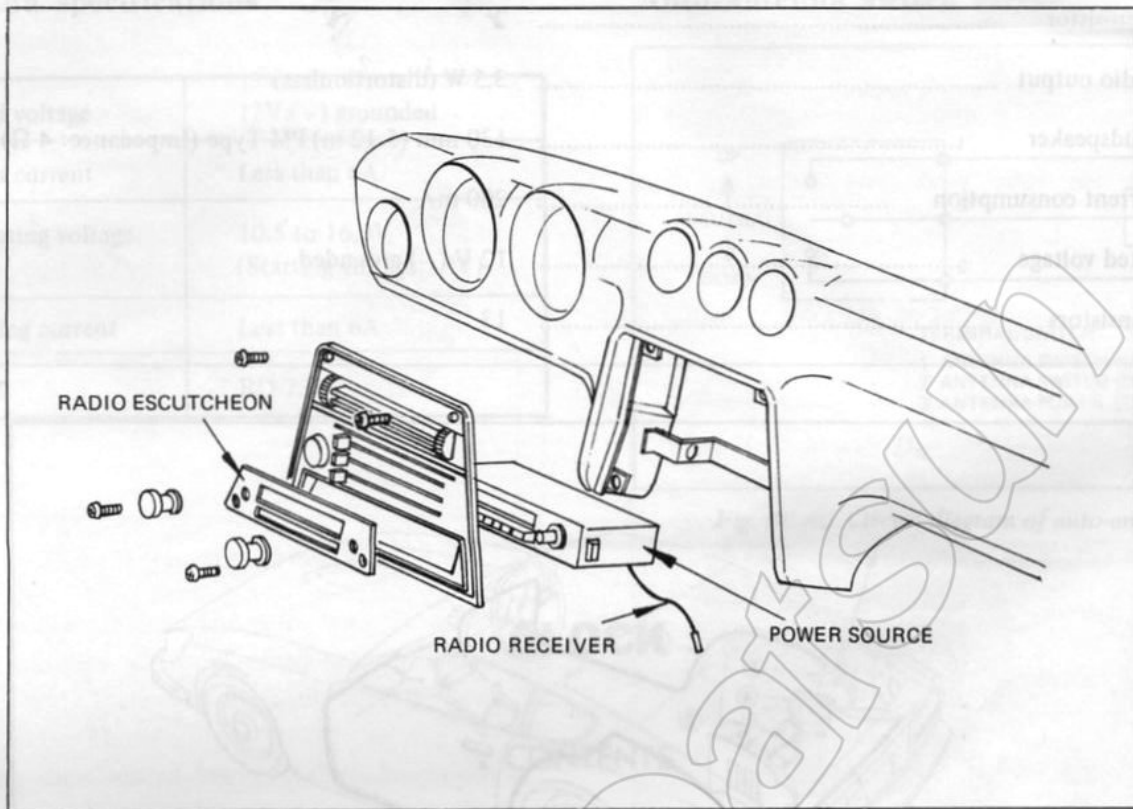

Fig. BE-37 Structural view of radio

The radio receiver proper is a special unit designed for the Model S30 vehicles. The radio receiver unit is fitted flush into the instrument console box.

The speaker is fitted into the left of the rear side inner. The antenna is of a power-drive design, and the length is 1,020 mm (40.5 in) when fully extended.

For the detail of Radio refer to "All-transistor car Radio MODEL KM1520ZC service manual" which is

published by Hitachi, Ltd.

Installation

When installing the radio receiver proper, first, install the radio on the instrument console finisher, and fit it into the instrument console. The radio manufacturer is Hitachi, Ltd.

Radio specifications

Model	KM1520ZC
Manufacturer	Hitachi, Ltd.
Tuning range	FM 88 to 108 MHz, AM 535 to 1,605 KHz
Circuit system	All transistor superheterodyne with RF amp.
IC	1
Diode	9

BODY

Thermistor	2
Audio output	3.5 W (distortionless)
Loudspeaker	130 mm (5.12 in) PM Type (Impedance: 4 Ω)
Current consumption	200 mA
Rated voltage	12 V (-) grounded
Transistors	13

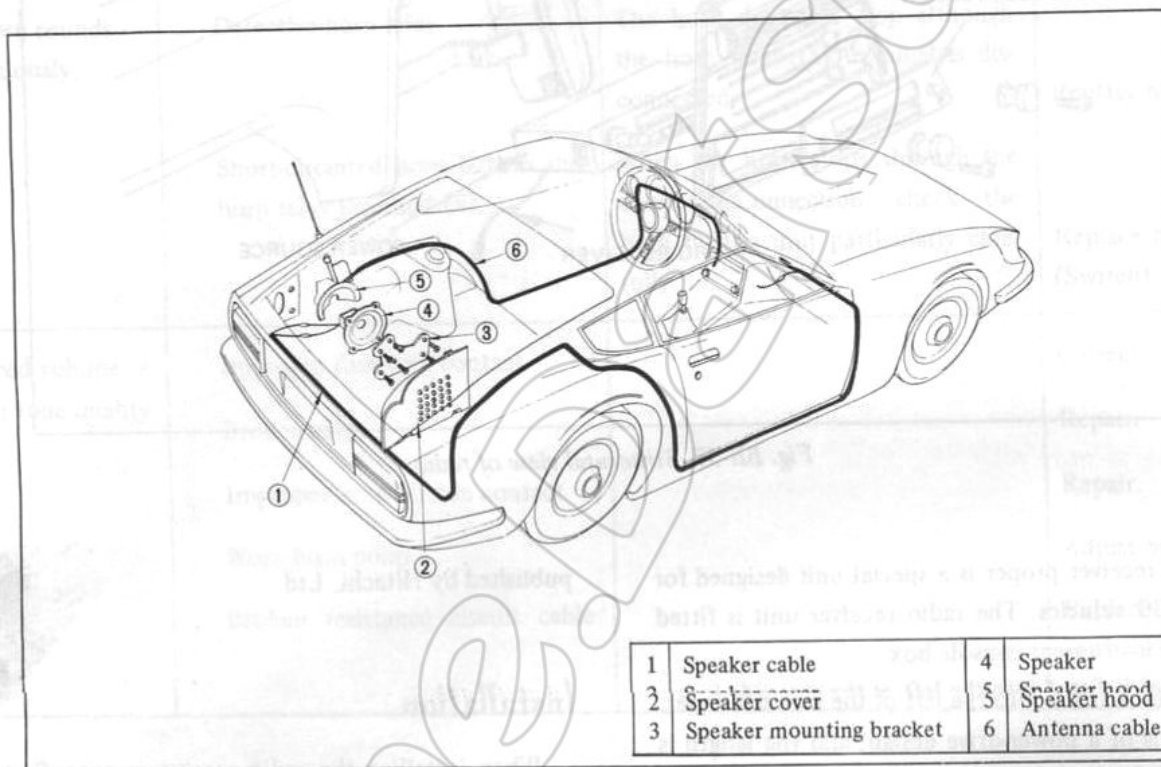

Fig. BE-38 Installing speaker and antenna

Installing speaker

First, install the speaker main unit and speaker hood on the speaker mounting bracket. With the speaker installed on the bracket, install the speaker mounting bracket on the body.

Installing antenna

1. Insert the antenna into the antenna installation hole on the left side rear fender from the passenger compartment side.
2. Install the antenna mounting bracket on the body side.
3. Install the antenna upper unit from the outside of the rear fender.

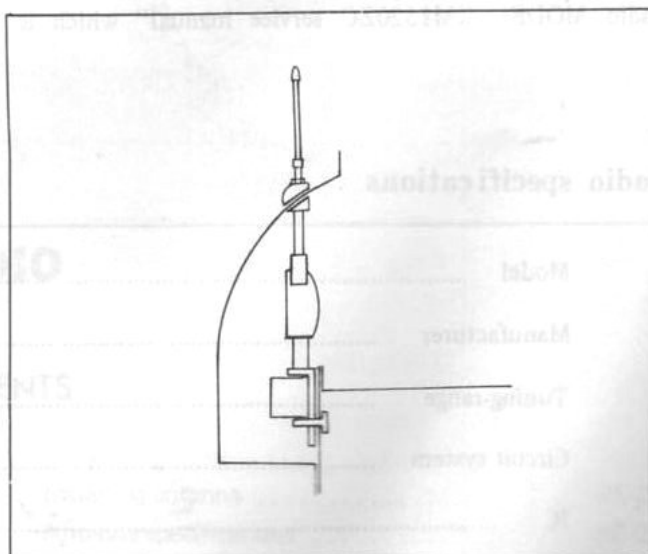

Fig. BE-39 Installing antenna

BODY ELECTRICAL

Antenna specifications

Rated voltage	12V (-) grounded
Rated current	Less than 6A
Operating voltage range	10.5 to 16.0V (Starting voltage: 9V)
Locking current	Less than 6A
Model	RO-73B

Auto-antenna switch circuit

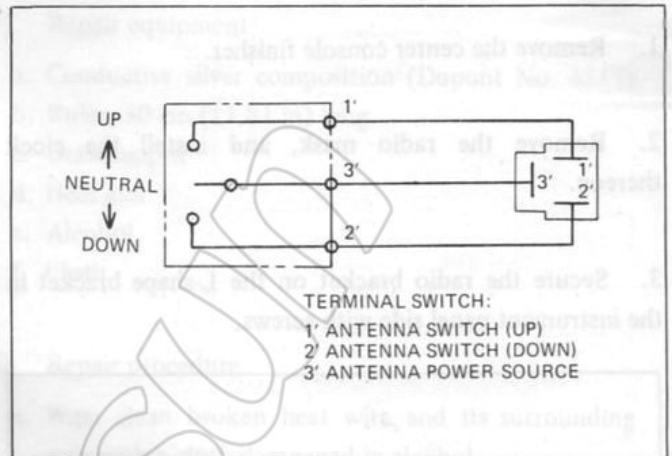

Fig. BE-40 Circuit diagram of auto-antenna

CLOCK

CONTENTS

Installation

BE-28

Adjusting clock

BE-28

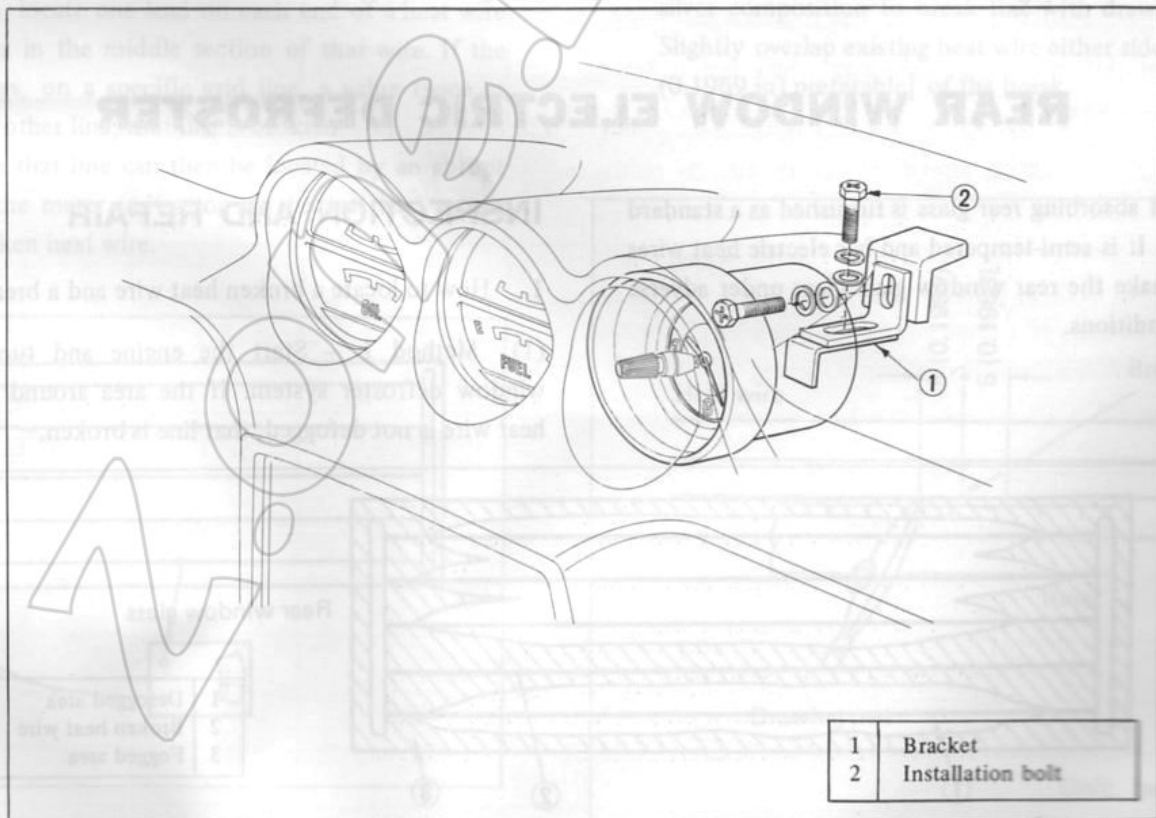

Fig. BE-41 Installing clock

Installation

1. Remove the center console finisher.
2. Remove the radio mask, and install the clock thereon.
3. Secure the radio bracket on the L-shape bracket in the instrument panel side with screws.

Adjusting clock

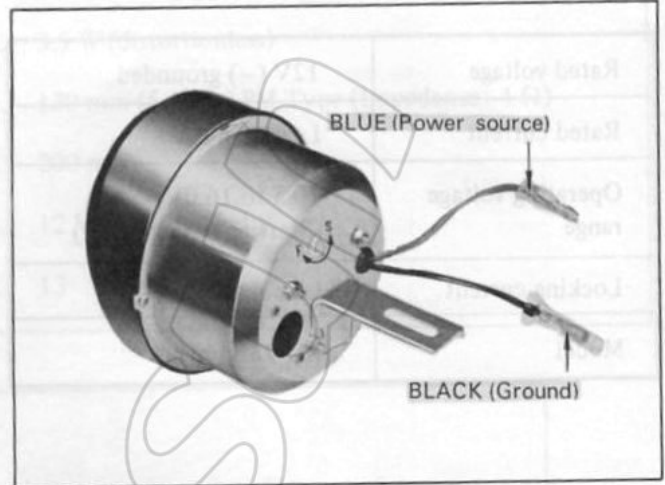

Fig. BE-43 Adjusting clock

Remove the vinyl cover, and adjust the adjusting screw shown in the above figure. When the adjusting screw is turned to "F", the clock gain and retard when turned to "S".

Recommend the adjustment be not made unless the clock is out of order considerably.

Be sure to reinstall the vinyl cover after adjustment. (The vinyl cover protects the clock from dust and other foreign matters.)

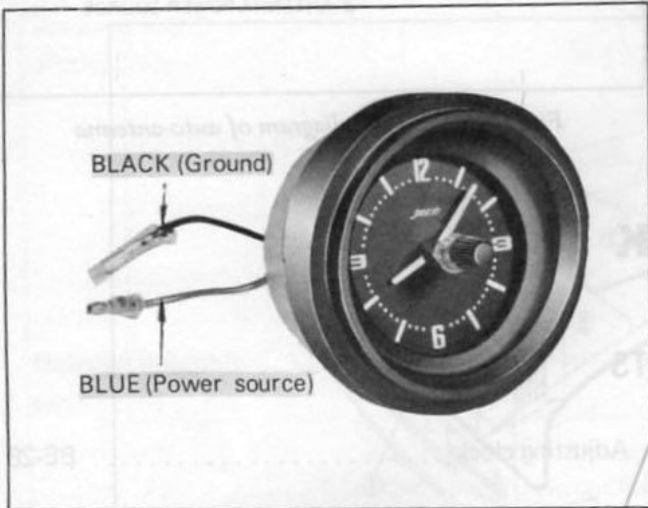

Fig. BE-42 Clock

REAR WINDOW ELECTRIC DEFROSTER

The heat absorbing rear glass is furnished as a standard equipment. It is semi-tempered and has electric heat wires baked to make the rear window glass clear under adverse weather conditions.

INSPECTION AND REPAIR

1. How to locate a broken heat wire and a break
 - (1) Method 1 - Start the engine and turn on the window defroster system. If the area around a specific heat wire is not defogged, that line is broken.

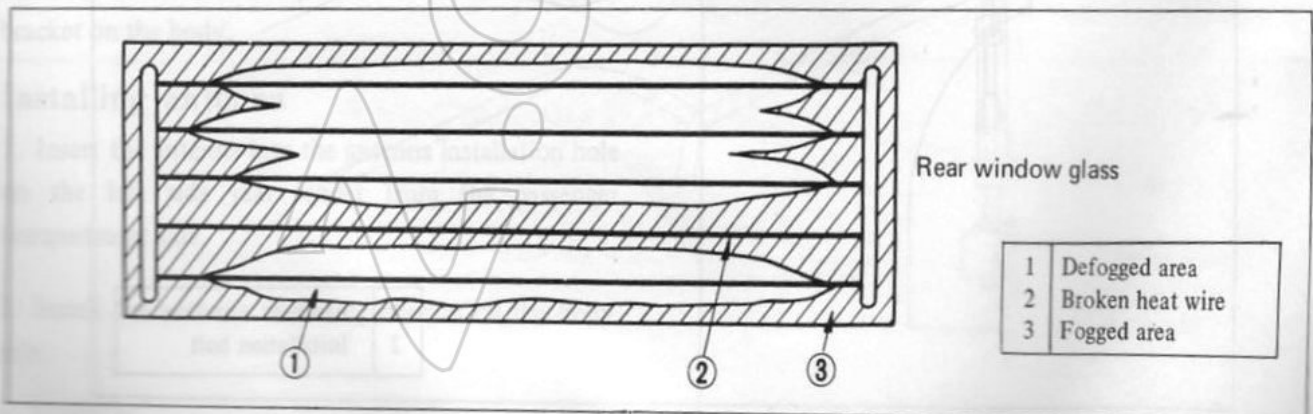

Fig. BE-44 Defogging pattern

BODY ELECTRICAL

(2) Method 2 — Start the engine and turn on the window defroster system. With a d-c voltmeter setup shown in Figure BE-45, check each heat wire for discontinuity. If the meter indicates 12 volts or 0 on a specific wire, that line is broken. (Normal indication: 6 volts)

A break in that line can then be detected by moving the positive lead of meter along the line until an abrupt variation in the meter indication is encountered.

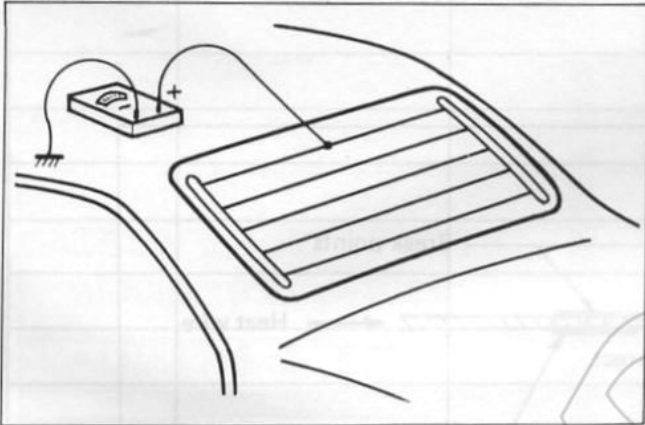

Fig. BE-45 Checking for broken heat wire with d-c voltmeter

(3) Method 3 — With an ohmmeter setup shown in Figure BE-46, locate one lead on each end of a heat wire and the other in the middle section of that wire. If the meter registers, on a specific grid line, a value twice as much on any other line, that line is broken.

A break in that line can then be located by an abrupt variation in the meter indication as the test lead moves along the broken heat wire.

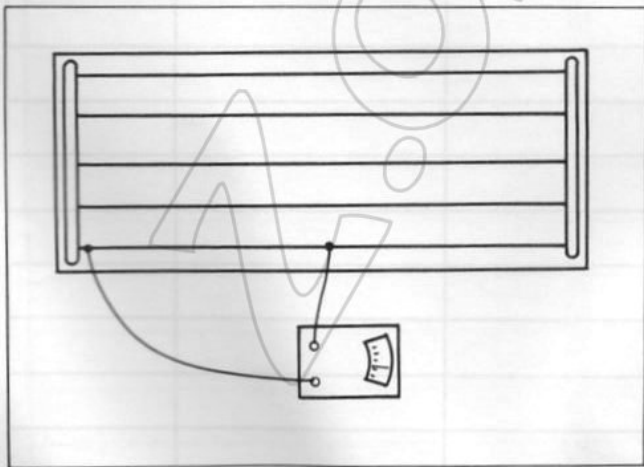

Fig. BE-46 Checking for broken heat wire with ohmmeter

2. Repair

(1) Repair equipment

- Conductive silver composition (Dupont No. 4817)
- Ruler, 30 cm (11.81 in) long
- Drawing pen
- Heat gun
- Alcohol
- Cloth

(2) Repair procedure

- Wipe clean broken heat wire and its surrounding area with a cloth dampened in alcohol.
- Apply a small amount of conductive silver composition to the tip of drawing pen.

Note: Shake silver composition container sufficiently before use.

- Place ruler on glass along broken line to be repaired as shown in Figure BE-47. Deposit conductive silver composition to break line with drawing pen. Slightly overlap existing heat wire either side [5 mm (0.1969 in) preferable] of the break.

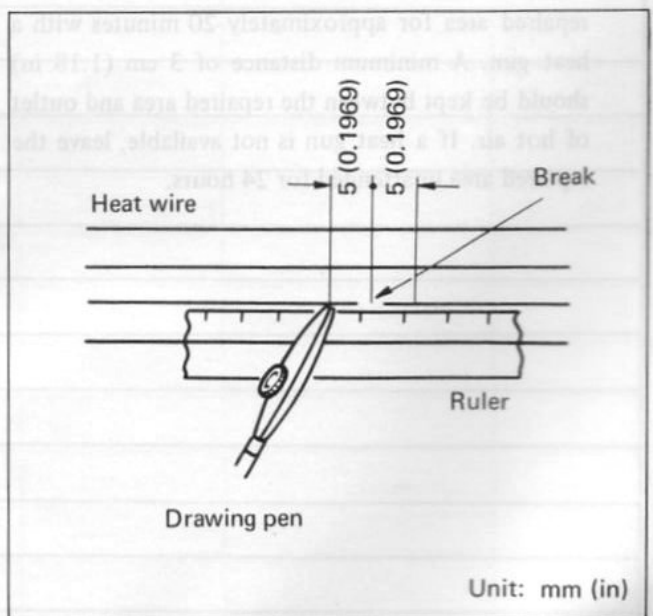

Fig. BE-47 Locating ruler in position

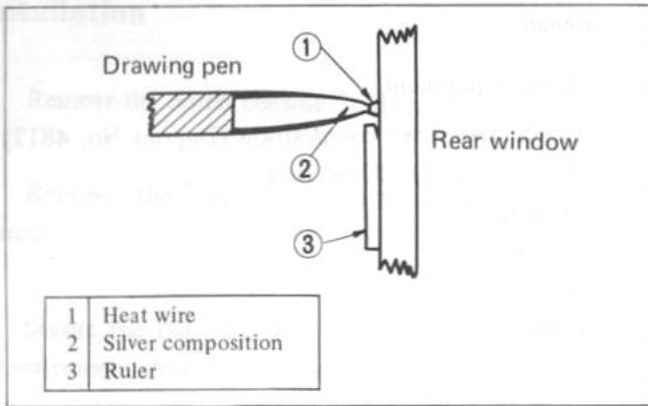

Fig. BE-48 Depositing silver composition in place

- d. Wipe clean silver composition from tip of drawing pen.
- e. After repair has been completed, check repaired wire for continuity. This check should be conducted 10 minutes after silver composition is deposited.

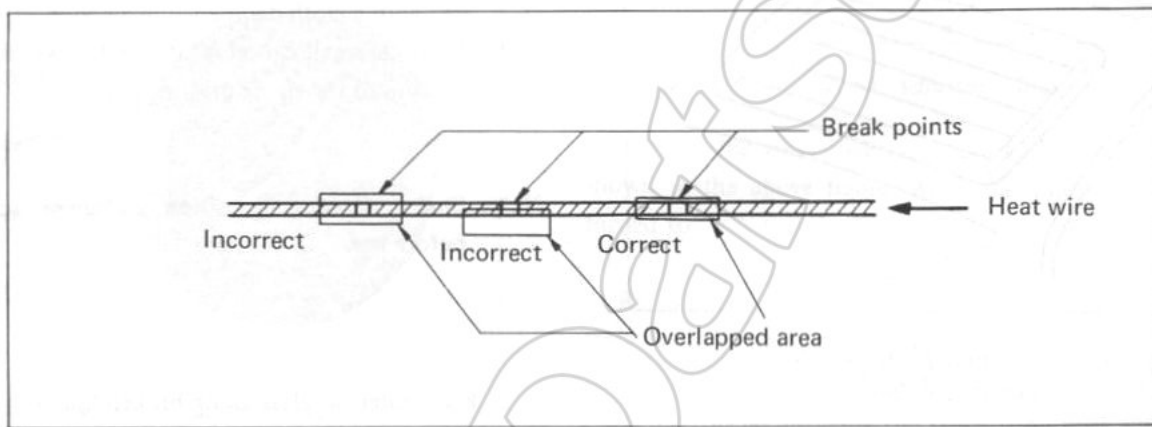

Fig. BE-49 Incorrect and correct deposition of silver composition

Note: Do not touch repaired area while test is being conducted.

- f. Apply a constant stream of hot air directly to the repaired area for approximately 20 minutes with a heat gun. A minimum distance of 3 cm (1.18 in) should be kept between the repaired area and outlet of hot air. If a heat gun is not available, leave the repaired area unattended for 24 hours.

(3) Instruction after repair

Wipe clean the repaired area with a soft, clean cloth.

Note: Do not use a cleaning solvent containing much soap water.

