

SECTION **GW**

GLASSES, WINDOW SYSTEM & MIRRORS

CONTENTS

WINDSHIELD GLASS	2	Wiring Diagram – WINDOW –	13	F
Removal and Installation	2	Terminals and Reference Value for Power Window		
REMOVAL	2	Main Switch	15	
INSTALLATION	3	Trouble Diagnosis Symptom Chart	15	G
SLIDE DOOR GLASS & SIDE WINDOW GLASS	4	Power Window Main Switch Power Supply and		
Push-in Type Weatherstrip	4	Ground Circuit Check	15	
REMOVAL AND INSTALLATION	4	Driver Power Window Motor Check	16	H
Slide Glass Type	5	Power Window Main Switch Check	16	
REMOVAL AND INSTALLATION	5	Passenger Power Window Switch Check	17	
BACK DOOR WINDOW GLASS	7	FRONT DOOR GLASS AND REGULATOR	18	GW
Removal and Installation	7	Removal and Installation	18	
REMOVAL	7	INSPECTION AFTER REMOVAL	20	
INSTALLATION	8	FITTING INSPECTION	20	
BACK DOOR WINDOW DEFOGGER	9	DOOR MIRROR	21	J
System Description	9	Removal and Installation	21	
TIMER FUNCTION	9	REMOVAL (B)	21	
Component Parts and Harness Connector Location	9	INSTALLATION (B)	21	K
Wiring Diagram – DEF –	10	OUT SIDE MIRROR & UNDER MIRROR	22	
Terminals and Reference Value for Combination		Removal and Installation	22	
Meter (Unified Meter Control Unit)	11	REAR UNDER MIRROR	23	L
POWER WINDOW SYSTEM	12	Removal and Installation	23	
Component Parts and Harness Connector Location	12			M

WINDSHIELD GLASS

PFP:72712

WINDSHIELD GLASS

Removal and Installation

EIS001LL

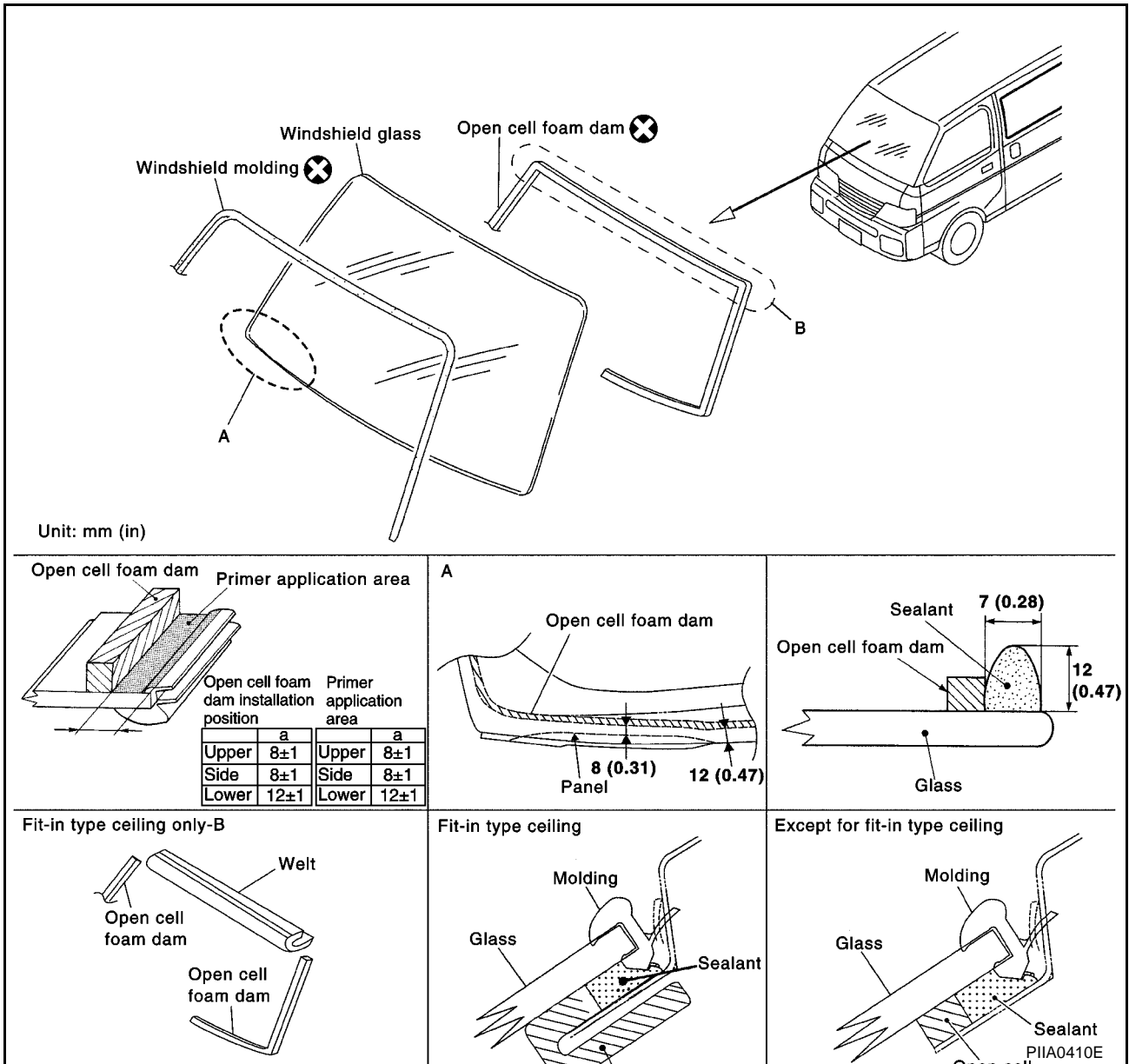

REMOVAL

1. Remove the front pillar garnish and head lining. Refer to [EI-22, "BODY SIDE TRIM"](#) and [EI-27, "HEAD-LINING"](#).
2. Remove the weather-strip on the front pillar.
3. Remove the cowl top cover. Refer to [EI-13, "COWL TOP"](#).
4. Apply a protective tape around the windshield glass to protect the painted surface from damage. After removing moldings, remove glass using piano wire or power cutting tool and an inflatable pump bag.
 - If a windshield glass is reversed, mark the body and the glass with mating marks.

WARNING:

When cutting the glass from the vehicle, always wear safety glasses and heavy gloves to help prevent glass splinters from entering your eyes or cutting your hands.

CAUTION:

When a windshield glass is reused, do not use a cutting knife or power cutting tool.

NOTE:

- Be careful not to scratch the glass when removing.

WINDSHIELD GLASS

- Do not set or stand the glass on its edge. Small chips may develop into cracks.

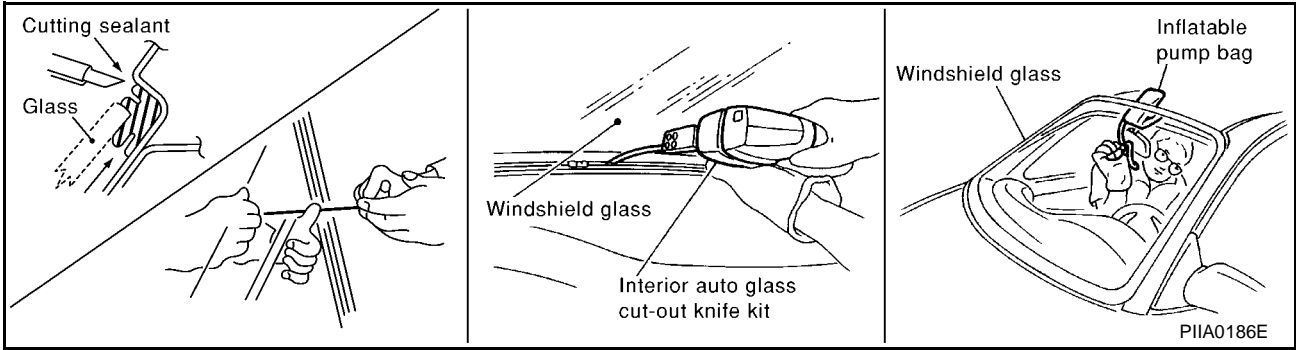

INSTALLATION

- Use a genuine Nissan Urethane Adhesive Kit or equivalent and follow the instructions furnished with it.
- While the urethane adhesive is curing, open a door window. This will prevent the glass from being forced out by passenger compartment air pressure when a door is closed.
- The molding must be installed securely so that it is in position and leaves no gap.
- Inform the customer that the vehicle should remain stationary until the urethane adhesive has completely cured (preferably 24 hours). Curing time varies with temperature and humidity.

WARNING:

- **Keep heat and open flames away as primers and adhesive are flammable.**
- **The materials contained in the kit are harmful if swallowed, and may irritate skin and eyes. Avoid contact with the skin and eyes.**
- **Use in an open, well ventilated location. Avoid breathing the vapors. They can be harmful if inhaled. If affected by vapor inhalation, immediately move to an area with fresh air.**
- **Driving the vehicle before the urethane adhesive has completely cured may affect the performance of the windshield in case of an accident.**

CAUTION:

- **Do not use an adhesive which is past its usable term. Shelf life of this product is limited to six months after the date of manufacture. Carefully adhere to the expiration or manufacture date printed on the box.**
- **Keep primers and adhesive in a cool, dry place. Ideally, they should be stored in a refrigerator.**
- **Do not leave primers or adhesive cartridge unattended with their caps open or off.**
- **The vehicle should not be driven for at least 24 hours or until the urethane adhesive has completely cured. Curing time varies depending on temperature and humidities. The curing time will increase under higher temperatures and lower humidities.**

Repairing Water Leaks for Windshield

Leaks can be repaired without removing and reinstalling glass.

If water is leaking between the urethane adhesive material and body or glass, determine the extent of leakage.

This can be done by applying water to the windshield area while pushing glass outward.

To stop the leak, apply primer (if necessary) and then urethane adhesive to the leak point.

SLIDE DOOR GLASS & SIDE WINDOW GLASS

SLIDE DOOR GLASS & SIDE WINDOW GLASS

PFP:83300

Push-in Type Weatherstrip REMOVAL AND INSTALLATION

EIS001J9

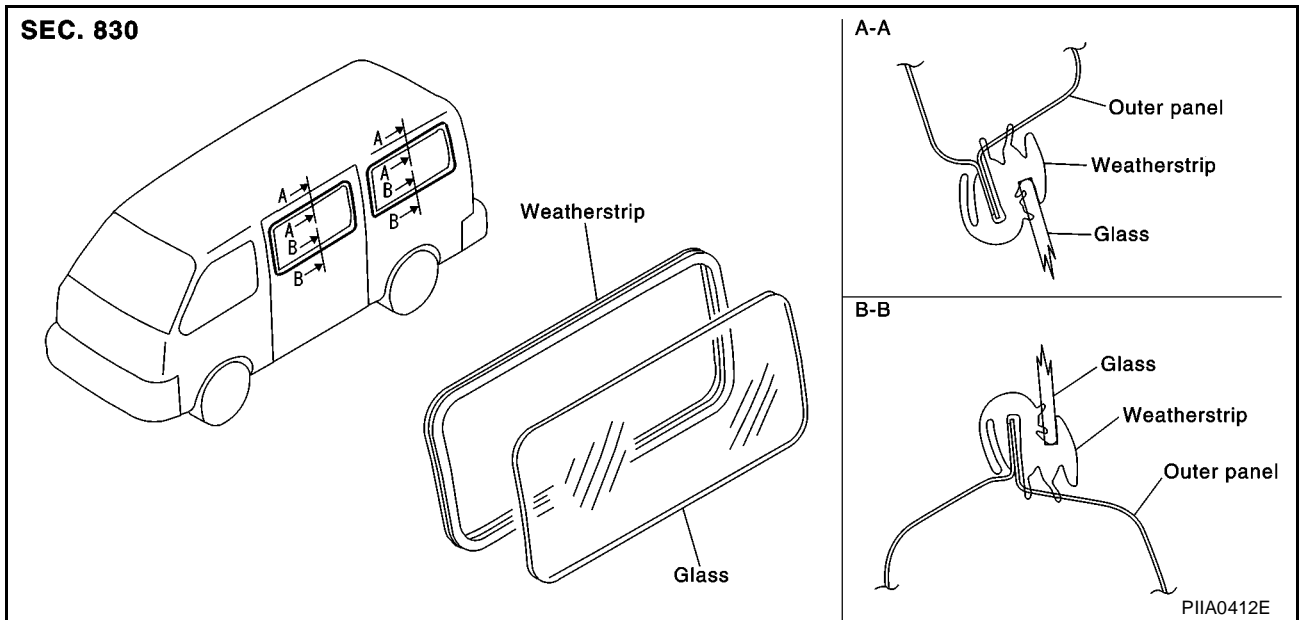

Sliding door

- Remove sliding door finisher. Refer to [EI-19, "DOOR FINISHER"](#).

Side window glass 1st

- Remove the following: center pillar upper garnish, rear pillar upper garnish and rear side upper finisher (Front). Refer to [EI-22, "BODY SIDE TRIM"](#).

Side window glass 2nd

- Remove the following: center pillar upper garnish, back pillar upper garnish and rear side upper finisher (Rear). Refer to [EI-22, "BODY SIDE TRIM"](#).

Removal

- Using a clip clamp tool in the cabin, pull weatherstrip outward to remove.

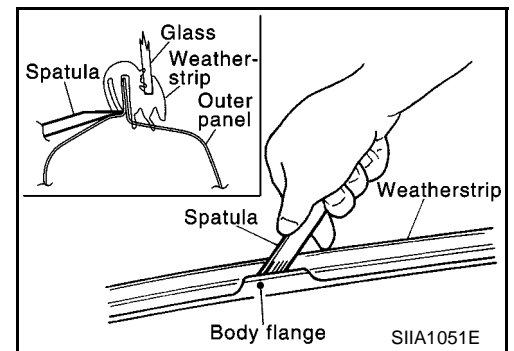

Installation

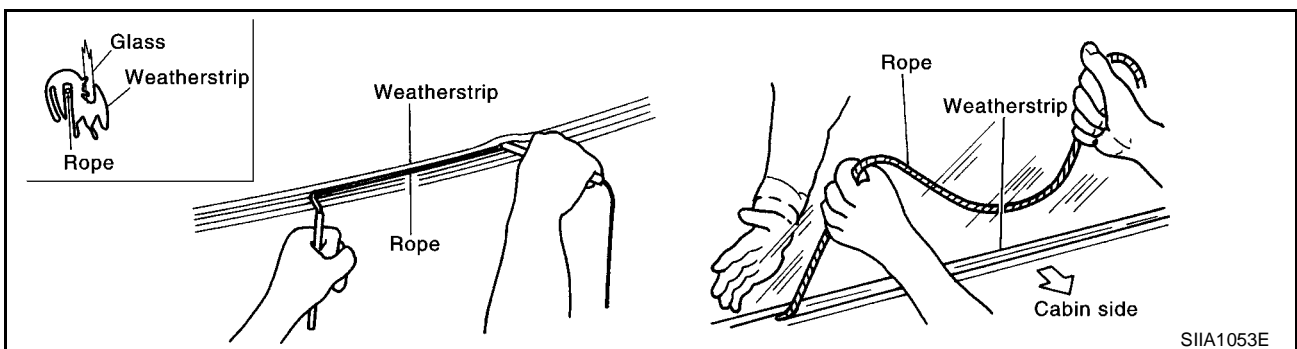

SLIDE DOOR GLASS & SIDE WINDOW GLASS

1. Insert rope into body flange inserting groove of the weatherstrip. (Both ends of the rope should be tied together at the lower center of weatherstrip.)
2. Align weatherstrip and body flange. Pull the rope in cabin and push glass from outside (at the same time) to fit weatherstrip and body flange.
3. After installing the glass, lightly tap weatherstrip all around with rubber hammer to completely fit weatherstrip and body flange.
4. Install the removed parts.

Slide Glass Type REMOVAL AND INSTALLATION

EIS001JA

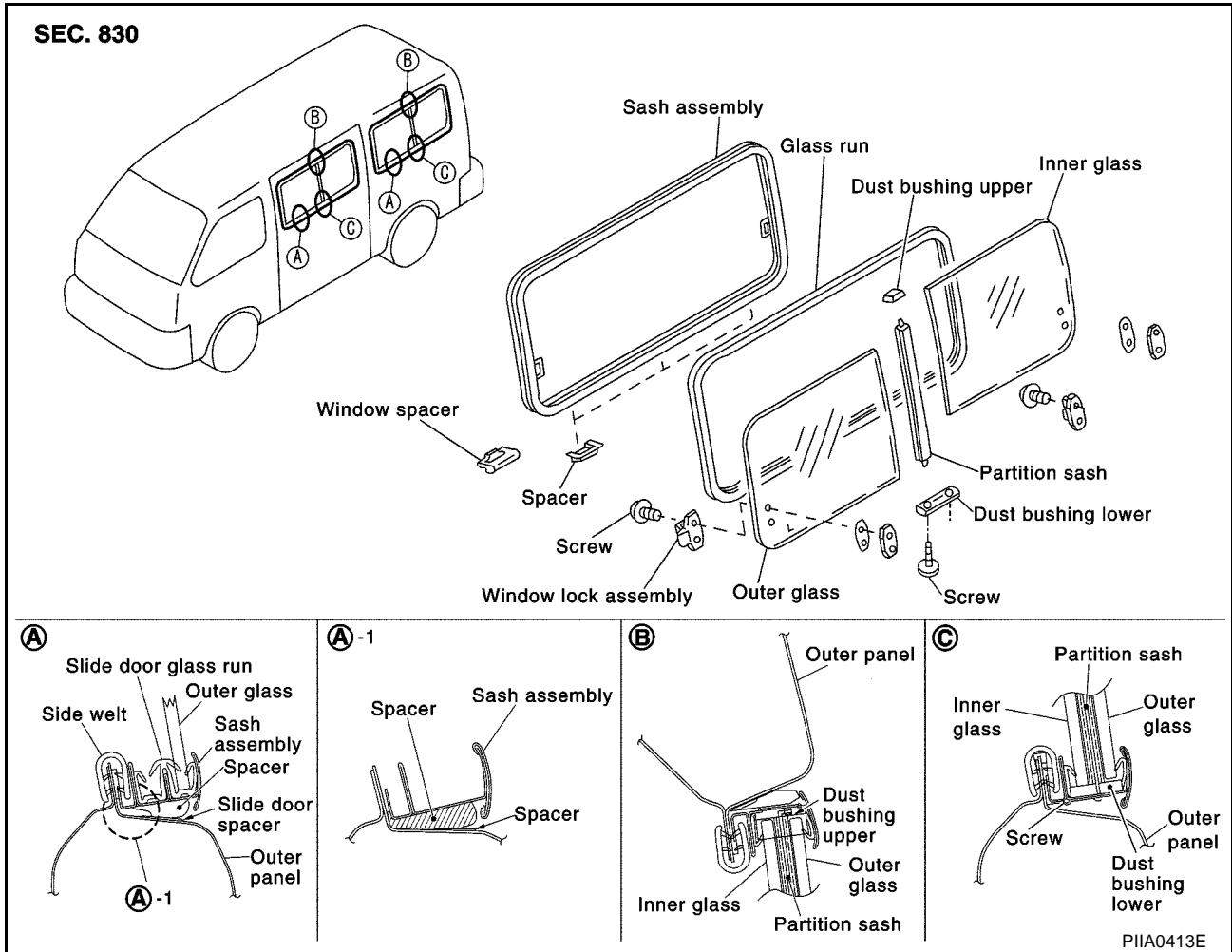

Sliding door

- Remove sliding door finisher. Refer to [EI-19, "DOOR FINISHER"](#).

Side window glass 1st

- Remove the following: center pillar upper garnish, rear pillar upper garnish and rear side upper finisher (Front). Refer to [EI-22, "BODY SIDE TRIM"](#).

Side window glass 2nd

- Remove the following: center pillar upper garnish, back pillar upper garnish and rear side upper finisher (Rear). Refer to [EI-22, "BODY SIDE TRIM"](#).

Removal

1. Remove body side welt. Refer to [EI-22, "BODY SIDE TRIM"](#).
2. Apply protective tape on body panel along the circumference window glass to protect coated surfaces from damage.

SLIDE DOOR GLASS & SIDE WINDOW GLASS

- Working from inside the cabin, insert a cutter knife between sash assembly and body panel. Then, cut off the adhesive.

CAUTION:

Cut carefully so that the tip end of cutter knife does not contact sash assembly or painted surface.

- Remove slide glass assembly out of body panel.

CAUTION:

The glass is very heavy. Be careful not to drop it.

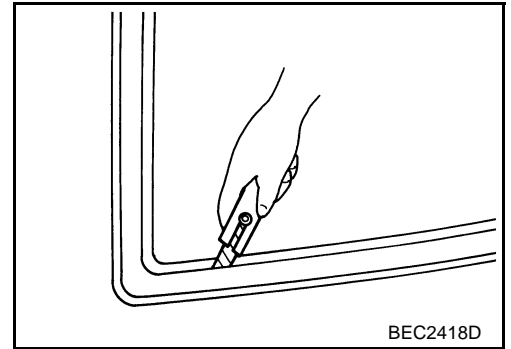

Installation

- Using a knife, remove remaining sealant on body down to approximately 2 mm (0.08 in) thick so that entire contour becomes smooth.

CAUTION:

If coated panel surface is scratched or cut, always repair with two-liquid type urethane paint. Do not use lacquer type paint.

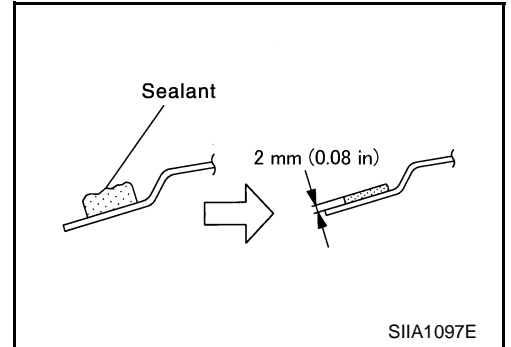

- With white gasoline, clean bonding areas around body panel and slide glass assembly.
- Apply primer along outer circumference of slide glass sash.

CAUTION:

If coated surface other than areas to be bonded is smeared with Primer M, immediately wipe off with white gasoline.

- After applying the primer, apply adhesive along entire circumference within the time specified in the instruction manual.
- Confirm installation position for slide glass assembly, and install it into panel.
- Lightly press across slide glass assembly for complete fitting.
- Using a spatula, go over areas with excessive or insufficient adhesive and neatly smooth the surface.

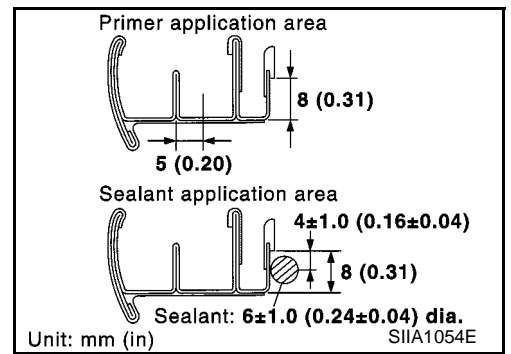

CAUTION:

After installing the glass, allow some time until adhesive is cured. Do not drive the vehicle until adhesive has finished curing.

- Perform the leak test.
- Peel off the protective tape. Install body side welt and other removed parts again.

BACK DOOR WINDOW GLASS

BACK DOOR WINDOW GLASS

PFP:90300

Removal and Installation

EIS001LM

A
B
C
D
E
F
G
H
J
K
L
M

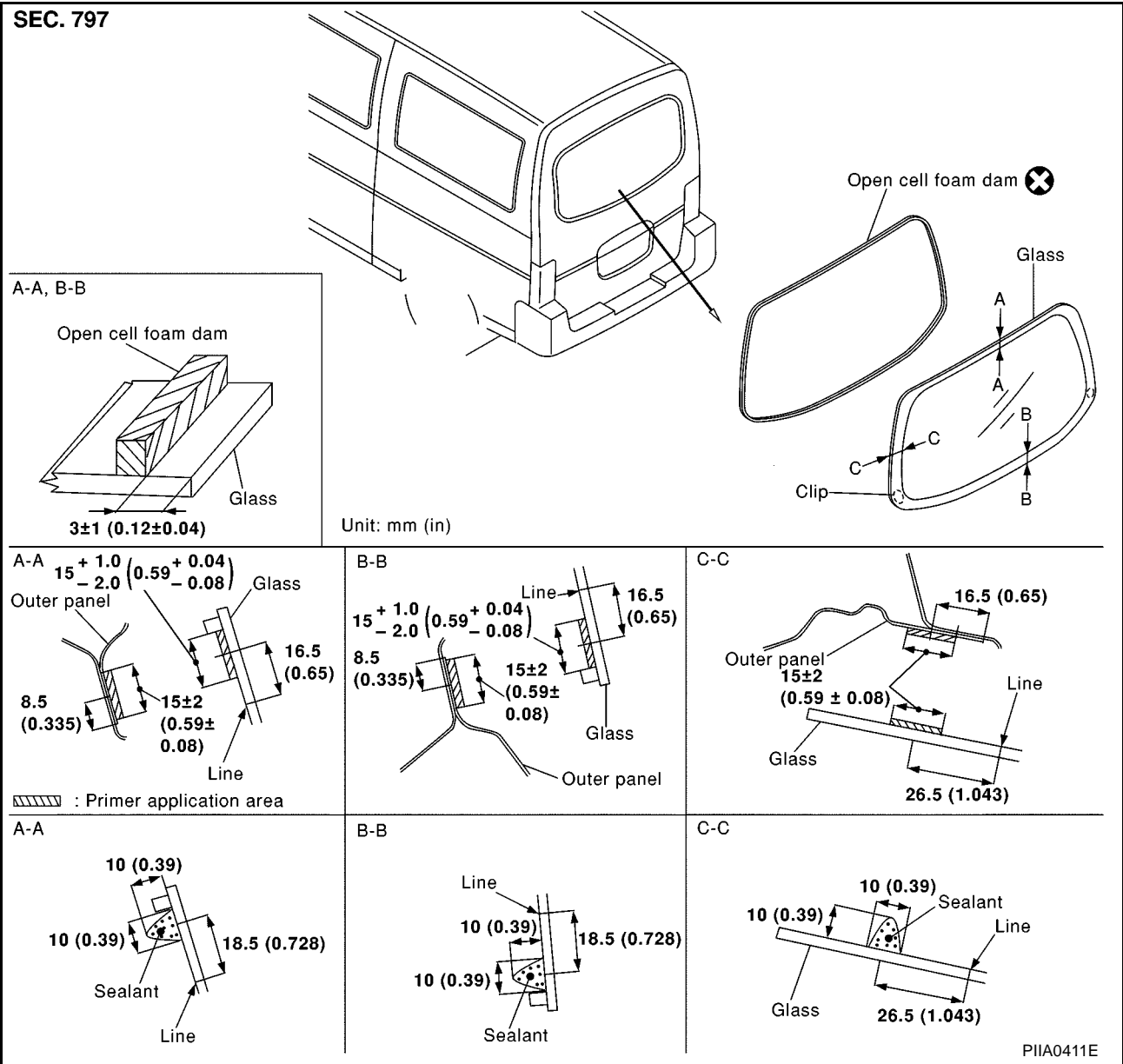

REMOVAL

1. Remove rear wiper. Refer to [WW-13, "Removal and Installation for Rear Wiper Arms"](#).
2. Remove the rear pillar garnish. Refer to [WW-15, "Removal and Installation for Rear Washer Nozzle"](#).
3. Remove the connectors and grounds for the rear defogger and printed antenna.
 - After removing moldings, remove glass using piano wire or power cutting tool and an inflatable pump bag.
 - If a windshield glass is reused, mark the body and the glass with mating marks.

WARNING:

When cutting the glass from the vehicle, always wear safety glasses and heavy gloves to help prevent glass splinters from entering your eyes or cutting your hands.

CAUTION:

- When a windshield glass is reused, do not use a cutting knife or power cutting tool.
- Be careful not to scratch the glass when removing.

BACK DOOR WINDOW GLASS

- Do not set or stand the glass on its edge. Small chips may develop into cracks.

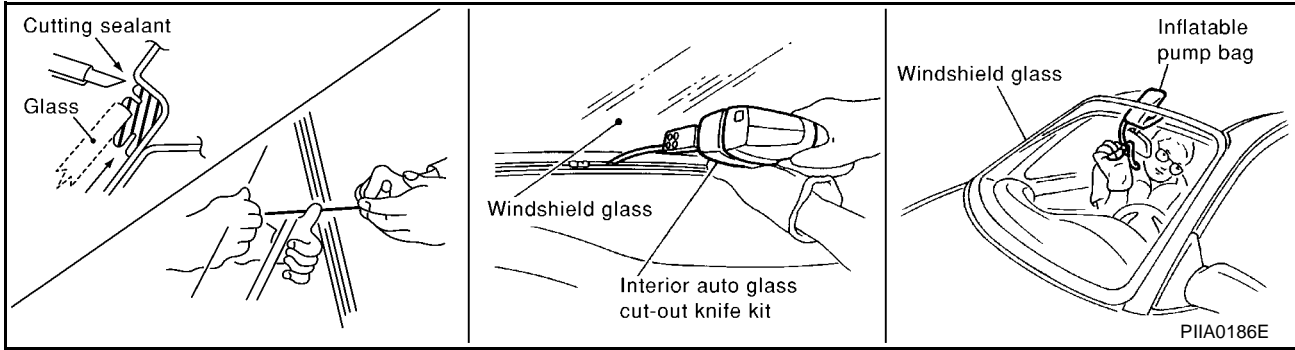

INSTALLATION

- Use a genuine Nissan Urethane Adhesive Kit or equivalent and follow the instructions furnished with it.
- While the urethane adhesive is curing, open a door window. This will prevent the glass from being forced out by passenger compartment air pressure when a door is closed.
- The molding must be installed securely so that it is in position and leaves no gap.
- Inform the customer that the vehicle should remain stationary until the urethane adhesive has completely cured (preferably 24 hours). Curing time varies with temperature and humidity.

WARNING:

- Keep heat and open flames away as primers and adhesive are flammable.
- The materials contained in the kit are harmful if swallowed, and may irritate skin and eyes. Avoid contact with the skin and eyes.
- Use in an open, well ventilated location. Avoid breathing the vapors. They can be harmful if inhaled. If affected by vapor inhalation, immediately move to an area with fresh air.
- Driving the vehicle before the urethane adhesive has completely cured may affect the performance of the windshield in case of an accident.

CAUTION:

- Do not use an adhesive which is past its usable term. Shelf life of this product is limited to six months after the date of manufacture. Carefully adhere to the expiration or manufacture date printed on the box.
- Keep primers and adhesive in a cool, dry place. Ideally, they should be stored in a refrigerator.
- Do not leave primers or adhesive cartridge unattended with their caps open or off.
- The vehicle should not be driven for at least 24 hours or until the urethane adhesive has completely cured. Curing time varies depending on temperature and humidities. The curing time will increase under higher temperatures and lower humidities.

BACK DOOR WINDOW DEFOGGER

PPF:90300

BACK DOOR WINDOW DEFOGGER

System Description TIMER FUNCTION

EIS0018L

- With ignition switch turned ON, when rear defogger switch is switched from OFF to ON, the switch sends an output signal to rear defogger, and simultaneously the timer starts (it remains ON for approximately 15 minutes).
- With timer working, when rear defogger switch is turned from OFF to ON, timer will be stopped. Output to defogger will also be stopped. When ignition switch is turned to ACC or OFF while timer is working, the same will happen.
- The meter control unit inside the meter controls the timer while defogger is activated.

Component Parts and Harness Connector Location

EIS0018M

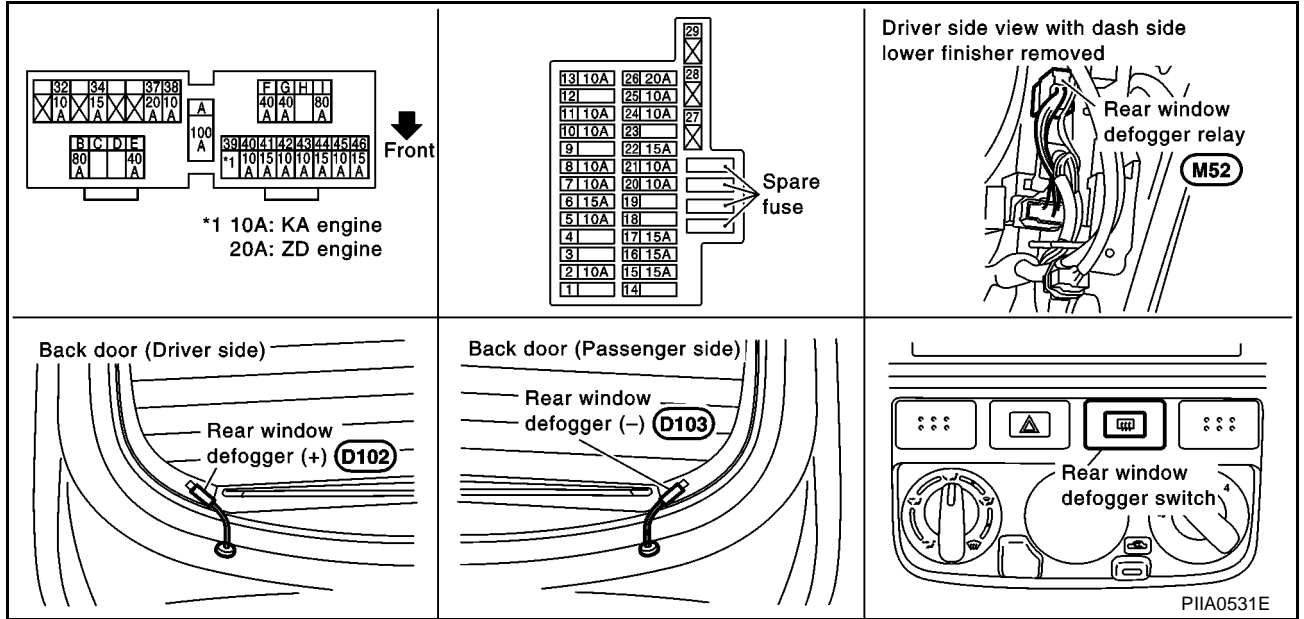

A
B
C
D
E
F
G
H
I
J
K
L
M

GW

BACK DOOR WINDOW DEFOGGER

Wiring Diagram – DEF –

EIS0018N

GW-DEF-01

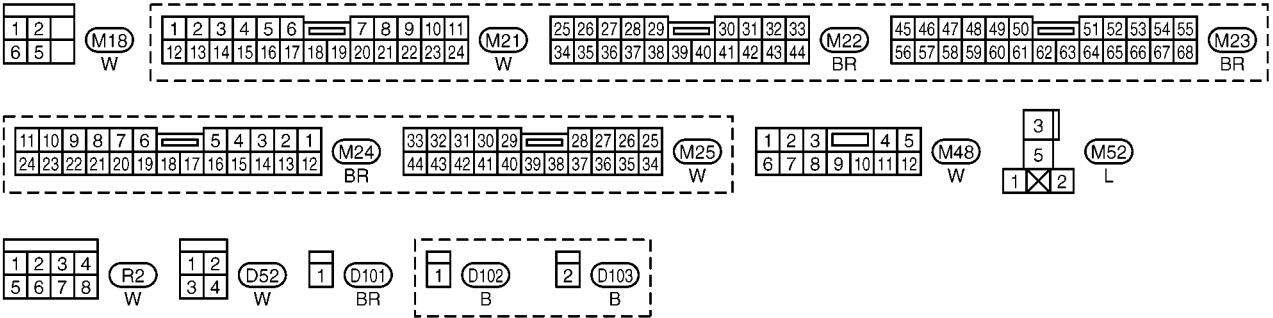
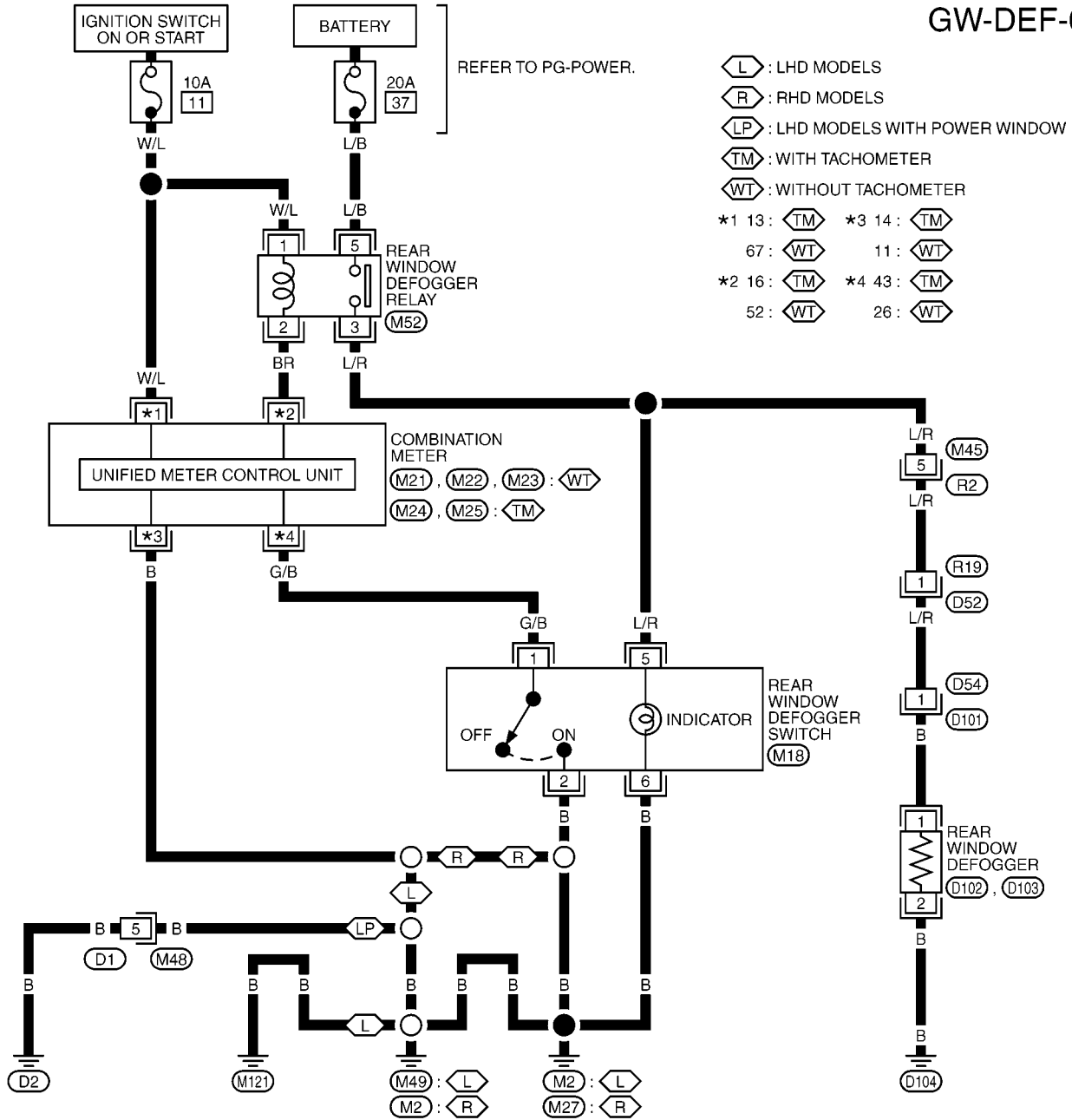

TIWH0010E

BACK DOOR WINDOW DEFOGGER

Terminals and Reference Value for Combination Meter (Unified Meter Control Unit)

EIS00180

Terminal	Wire color	Item	Condition	Voltage (Approximate values)
26 (43)	G/B	Rear defogger switch	Rear defogger switch OFF→ ON	Battery voltage → 0V
52 (16)	BR	Rear defogger relay	Rear defogger switch OFF→ ON	Battery voltage → 0V
67 (13)	W/L	IGN power supply	—	Battery voltage
11 (14)	B	Ground	—	0V

(): With tachometer

A

B

C

D

E

F

G

H

GW

J

K

L

M

POWER WINDOW SYSTEM

POWER WINDOW SYSTEM

PFP:25401

Component Parts and Harness Connector Location

EIS001LN

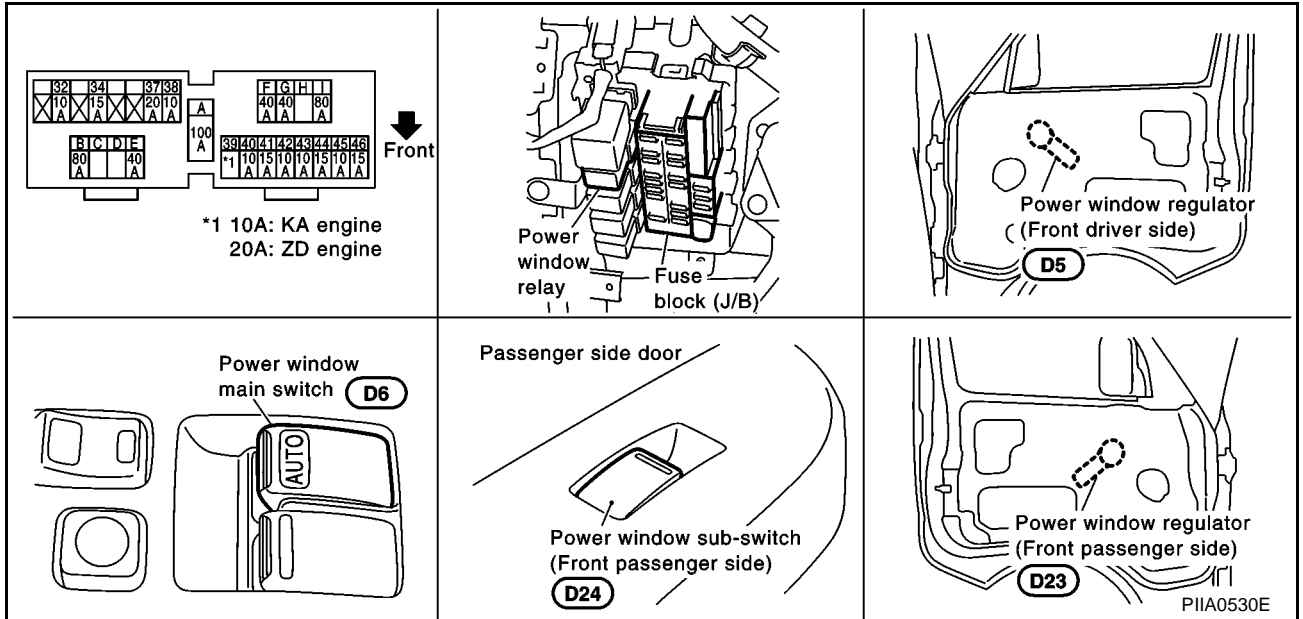

POWER WINDOW SYSTEM

Wiring Diagram – WINDOW –

EIS001LO

GW-WINDOW-01

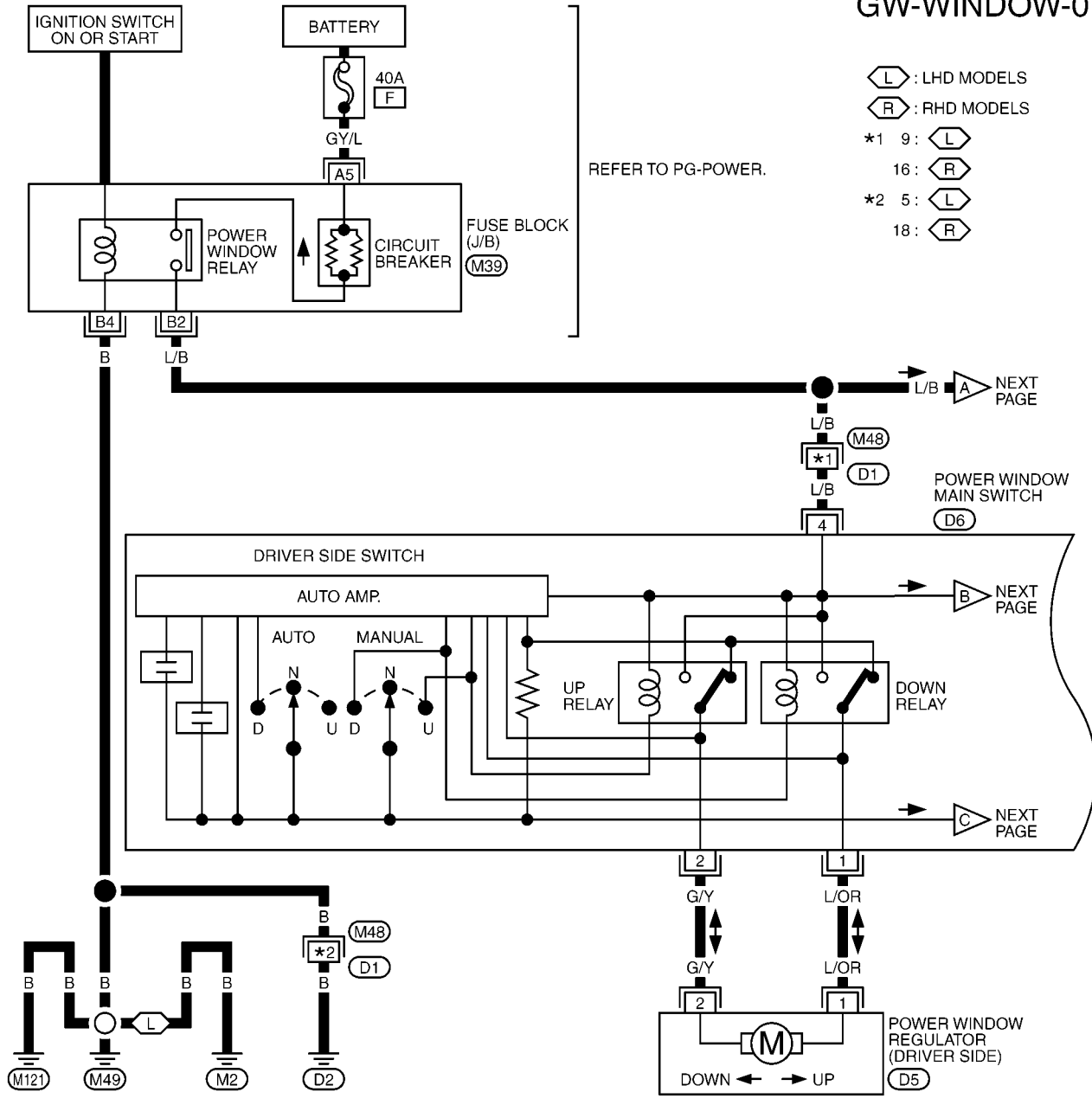

- ◁ L ▷ : LHD MODELS
- ◁ R ▷ : RHD MODELS
- *1 9 : ◁ L ▷
- 16 : ◁ R ▷
- *2 5 : ◁ L ▷
- 18 : ◁ R ▷

REFER TO PG-POWER.

L/B A NEXT PAGE

POWER WINDOW MAIN SWITCH (D6)

B NEXT PAGE

C NEXT PAGE

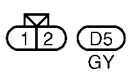
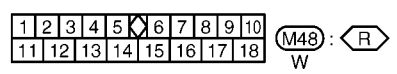
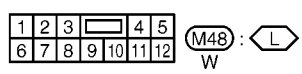

REFER TO THE FOLLOWING.
(M39) - FUSE BLOCK-JUNCTION BOX (J/B)

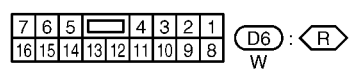
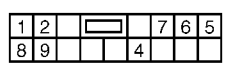

A
B
C
D
E
F
G
H
I
J
K
L
M

GW

POWER WINDOW SYSTEM

GW-WINDOW-02

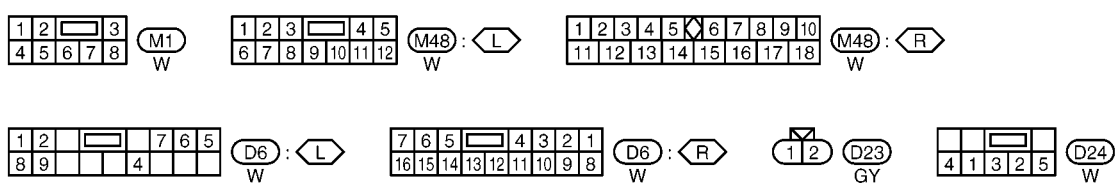
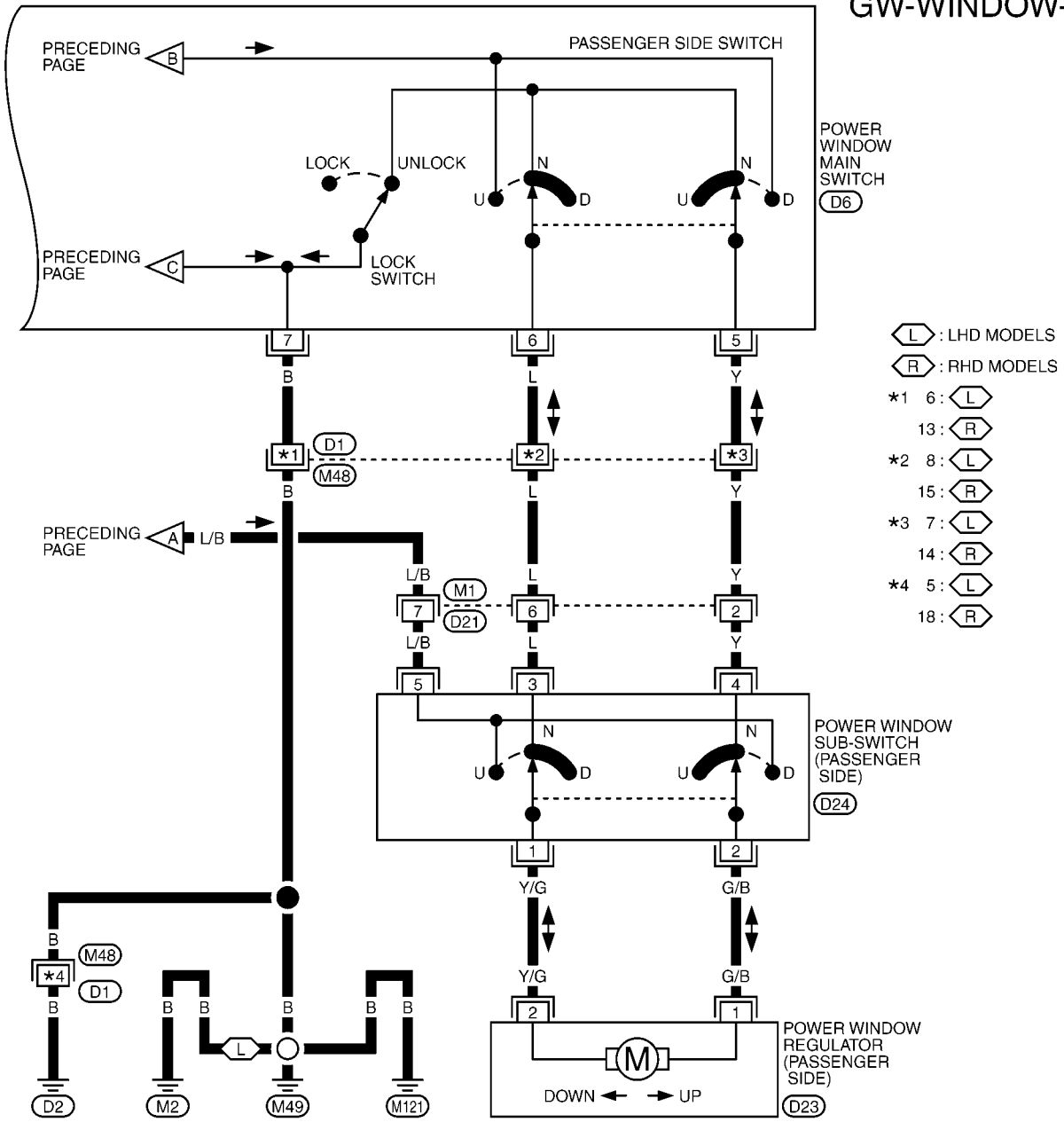

TIWH0012E

POWER WINDOW SYSTEM

Terminals and Reference Value for Power Window Main Switch

EIS001LP

Terminal	Wire color	Item	Condition	Voltage (Approximate values)
1	L/OR	Driver power window motor DOWN	Driver DOWN switch ON	0V → Battery voltage
2	G/Y	Driver power window motor UP	Driver UP switch ON	0V → Battery voltage
4	L/B	BAT power supply	–	Battery voltage
5	Y	Passenger power window DOWN	Passenger DOWN switch ON	0V → Battery voltage
6	L	Passenger power window UP	Passenger UP switch ON	0V → Battery voltage
7	B	Ground	–	0V

Trouble Diagnosis Symptom Chart

EIS001LQ

- Check that other systems using the signal of the following systems operate normally.

Symptom	Diagnostic procedure
All the power windows are inoperative.	Power window main switch power supply and ground circuit check. Refer to GW-15 .
Driver power window does not operate.	Driver power window motor check. Refer to GW-16 .
Passenger power window is inoperative. (The window can be operated with the passenger power window switch.)	Power window main switch check. Refer to GW-16 .
Passenger power window is inoperative. (The window can be operated with the power window main switch.)	Passenger power window switch check. Refer to GW-17 .

Power Window Main Switch Power Supply and Ground Circuit Check

EIS001LR

1. POWER WINDOW RELAY CIRCUIT CHECK

GW

1. Disconnect power window main switch connector.
2. Turn ignition switch to ON.
3. Check voltage between power window main switch harness connector D6 terminal 4(L/B) and body ground.

: Battery should exist.

OK or NG?

OK >> GO TO 2.

NG >> ● Check power window relay power supply circuit harness for open or short circuit.

- Check harness for open or short between power window relay and power window main switch.

2. POWER WINDOW MAIN SWITCH GROUND CIRCUIT CHECK

Check continuity between power window main switch harness connector D6 terminal 7(B) and body ground.

: Continuity should exist.

OK or NG?

OK >> Replace power window main switch.

NG >> Check ground circuit harness for open or short circuit.

POWER WINDOW SYSTEM

Driver Power Window Motor Check

EIS001LS

1. POWER WINDOW MOTOR CIRCUIT CHECK

1. Disconnect driver power window motor connector and power window main switch connector.
2. Check continuity between driver power window motor harness connector D5 terminals 1(L/OR), 2(G/Y) and power window main switch harness connector D6 terminals 1(L/OR), 2(G/Y).

1 - 1 : Continuity should exist.

2 - 2 : Continuity should exist.

OK or NG?

OK >> GO TO 2.

NG >> Check harness for open or short between driver power window motor and power window main switch.

2. POWER WINDOW MAIN SWITCH SIGNAL CHECK

1. Connect power window main switch connector.
2. Turn ignition switch to ON.
3. Check voltage between driver power window motor harness connector D5 terminals 1(L/OR), 2(G/Y) and body ground.

Terminal		Power window main switch	Voltage (Approximate values)
(+)	(-)		
1(L/OR)	Body ground	Driver DOWN switch ON	0V → Battery voltage
2(G/Y)		Driver UP switch ON	0V → Battery voltage

OK or NG?

OK >> Replace driver power window motor.

NG >> Replace power window main switch.

Power Window Main Switch Check

EIS001LT

1. POWER WINDOW MAIN SWITCH CIRCUIT CHECK

1. Disconnect power window main switch connector and passenger power window switch connector.
2. Check continuity between power window main switch harness connector D6 terminals 5(Y), 6(L) and passenger power window switch harness connector D24 terminals 3(L), 4(Y).

5 - 4 : Continuity should exist.

6 - 3 : Continuity should exist.

OK or NG?

OK >> Replace power window main switch.

NG >> Check harness for open or short between passenger power window switch and power window main switch.

POWER WINDOW SYSTEM

Passenger Power Window Switch Check

EIS001LU

1. POWER WINDOW RELAY CIRCUIT CHECK

1. Disconnect passenger power window switch connector.
2. Turn ignition switch to ON.
3. Check voltage between passenger power window switch harness connector D24 terminal 5(L/B) and body ground.

: Battery voltage should exist.

OK or NG?

OK >> GO TO 2.

NG >> Check harness for open or short between power window relay and driver power window switch.

2. PASSENGER POWER WINDOW CHECK

1. Connect passenger power window switch connector.
2. Disconnect passenger power window motor connector.
3. Check voltage between passenger power window motor harness connector D23 terminals 1(G/B), 2(Y/G) and body ground.

Terminal		Passenger power window switch	Voltage (Approximate values)
(+)	(-)		
1(G/B)	Body ground	DOWN switch ON	0V → Battery voltage
2(Y/G)		UP switch ON	0V → Battery voltage

OK or NG?

OK >> Check harness for open or short between passenger power window switch and passenger power window motor.

NG >> Replace passenger power window switch

A

B

C

D

E

F

G

H

GW

J

K

L

M

FRONT DOOR GLASS AND REGULATOR

PFP:80300

EIS0018Y

FRONT DOOR GLASS AND REGULATOR

Removal and Installation

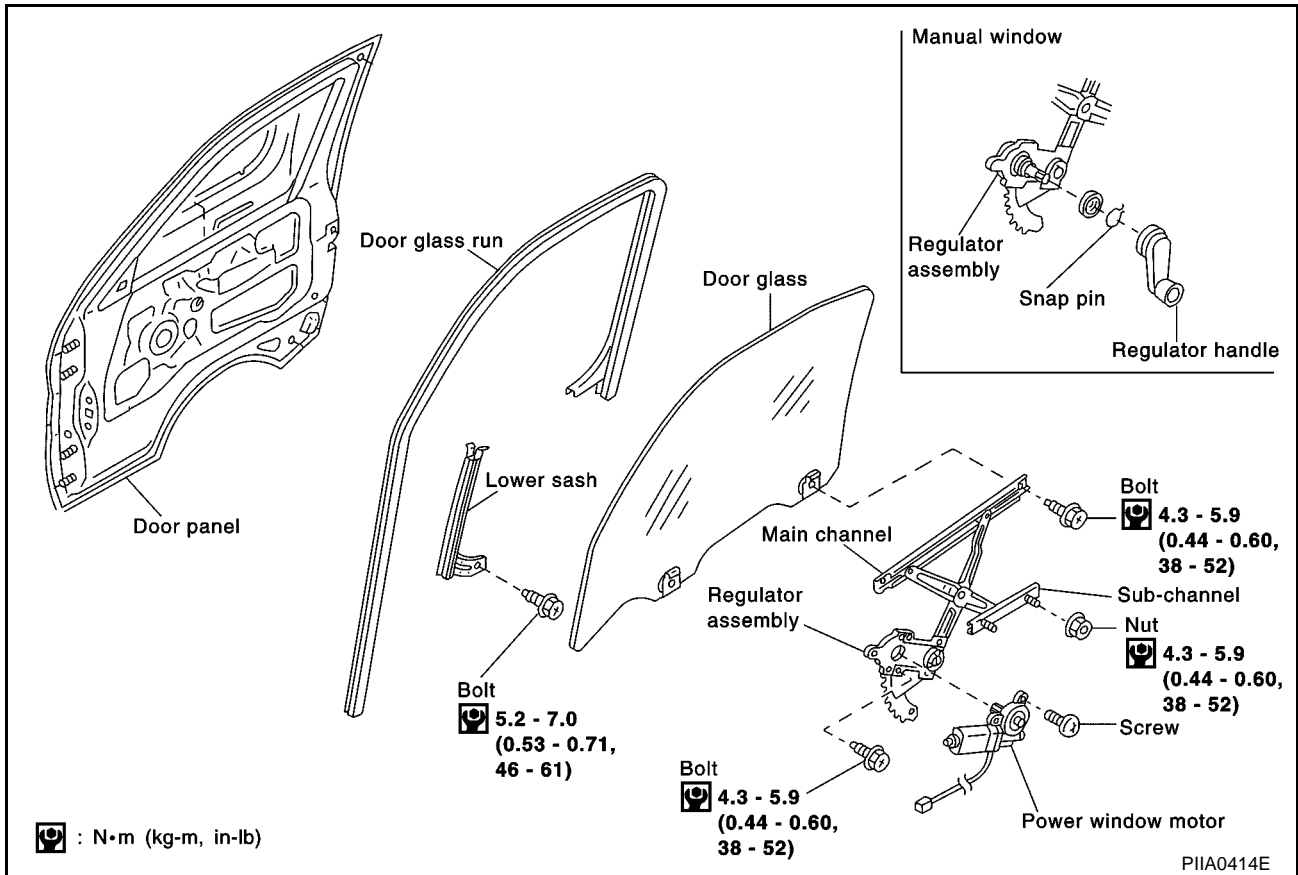

1. Remove front door finisher. Refer to [EI-19, "DOOR FINISHER"](#).

2. Remove sealing screen.

NOTE:

If sealing screen is reused, cut butyl tape in a way that leaves it on the sealing screen.

3. Remove lower sash mounting bolts.

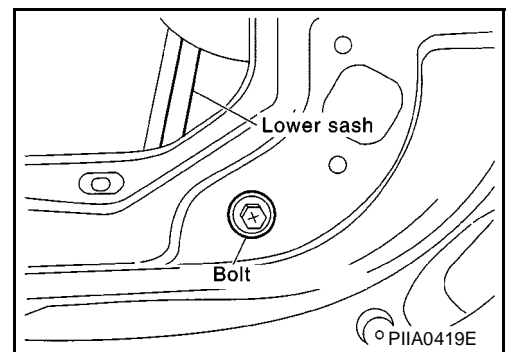

4. Raise door glass to fully closed position. Pull lower sash out of front door sash.

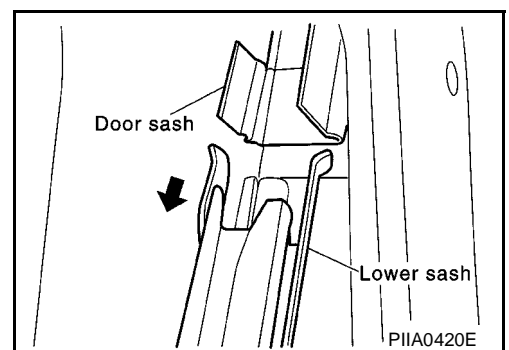

FRONT DOOR GLASS AND REGULATOR

5. Operate power window main switch to lower door glass until door glass mounting bolts are accessible.
6. Remove door glass mounting bolts.

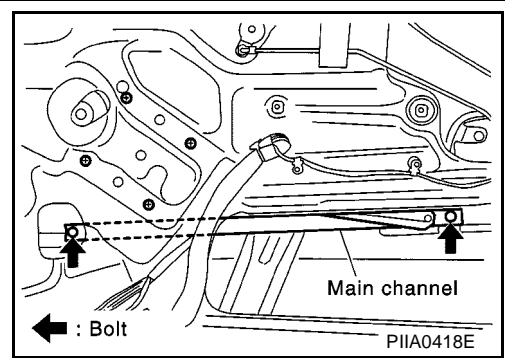

7. While holding door glass, raise it at the rear end to pull glass out of the sash toward the outside.

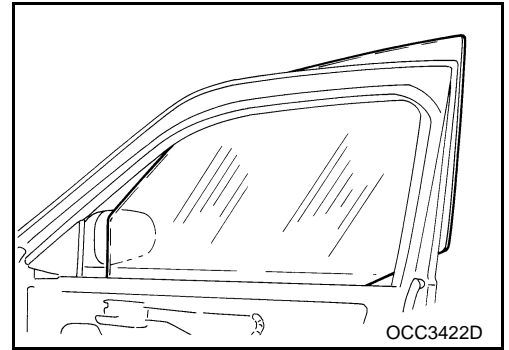

8. Remove sub channel mounting nuts.

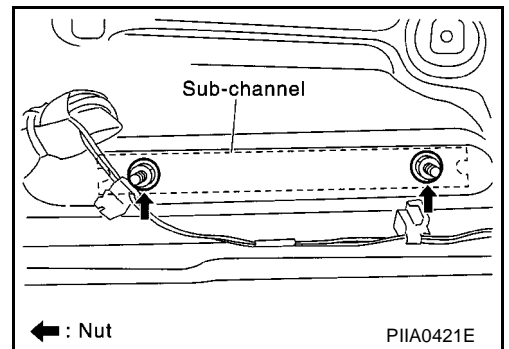

9. Disconnect power window motor connector.
 10. Remove regulator assembly mounting bolts to remove the assembly out of door panel.
- Install in the reverse order of removal.

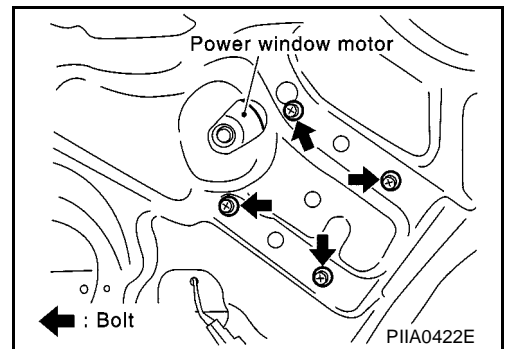

A
B
C
D
E
F
G
H
GW
J
K
L
M

FRONT DOOR GLASS AND REGULATOR

INSPECTION AFTER REMOVAL

Check regulator assembly for the following items. If a malfunction is detected, replace or grease it.

- Wire wear
- Regulator deformation
- Grease condition for each sliding part

NOTE:

The arrows in the figure show body grease application points.

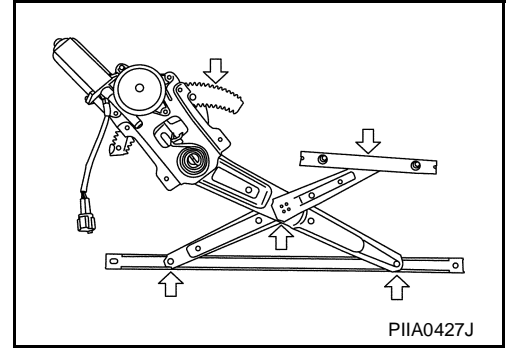

FITTING INSPECTION

- Check that the glass is securely fit into the glass run groove.
- While raising and lowering the window, check for any unusual operation.

DOOR MIRROR

DOOR MIRROR

PFP:96301

Removal and Installation

EIS0018Z

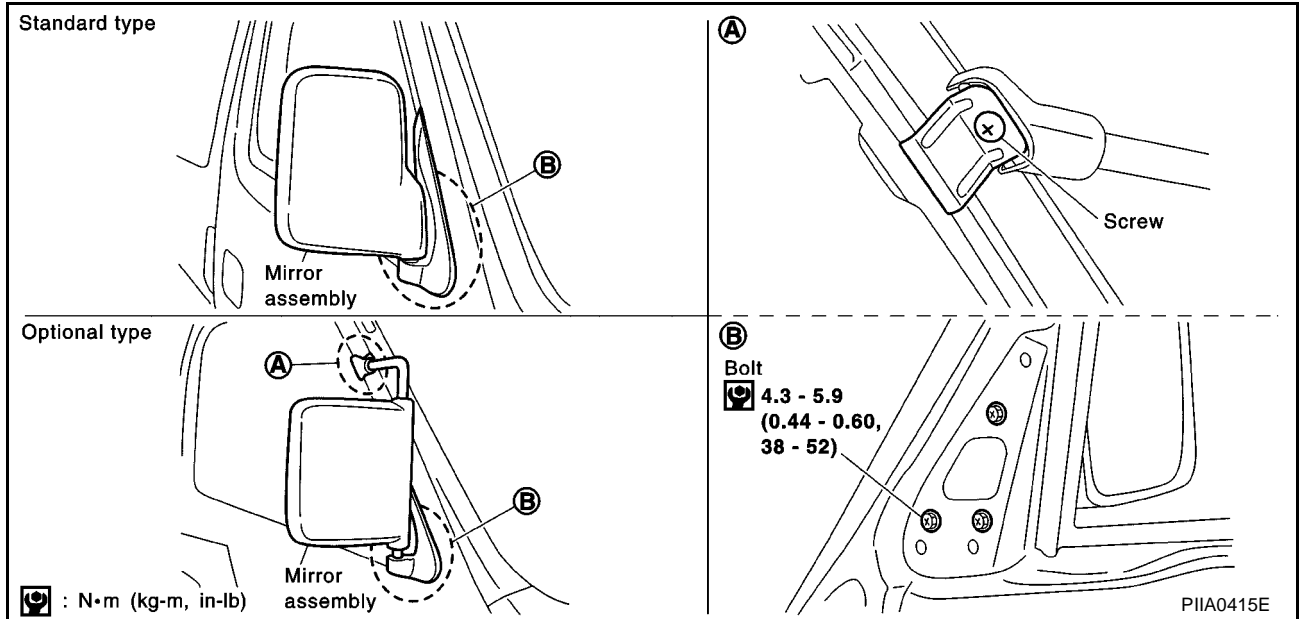

REMOVAL (B)

1. Remove front door trim. Refer to [EI-19, "DOOR FINISHER"](#).
2. Remove corner cover inner (clipped at 3 locations).
3. Remove mounting bolts to remove door outside finisher.

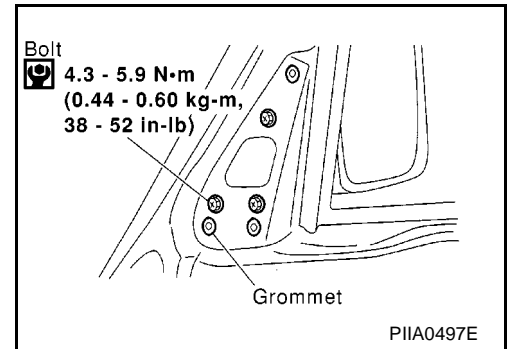

INSTALLATION (B)

Install in the reverse order of removal.

A
B
C
D
E
F
G
H
J
K
L
M

GW

OUT SIDE MIRROR & UNDER MIRROR

OUT SIDE MIRROR & UNDER MIRROR

PFP:96302

Removal and Installation

EIS00191

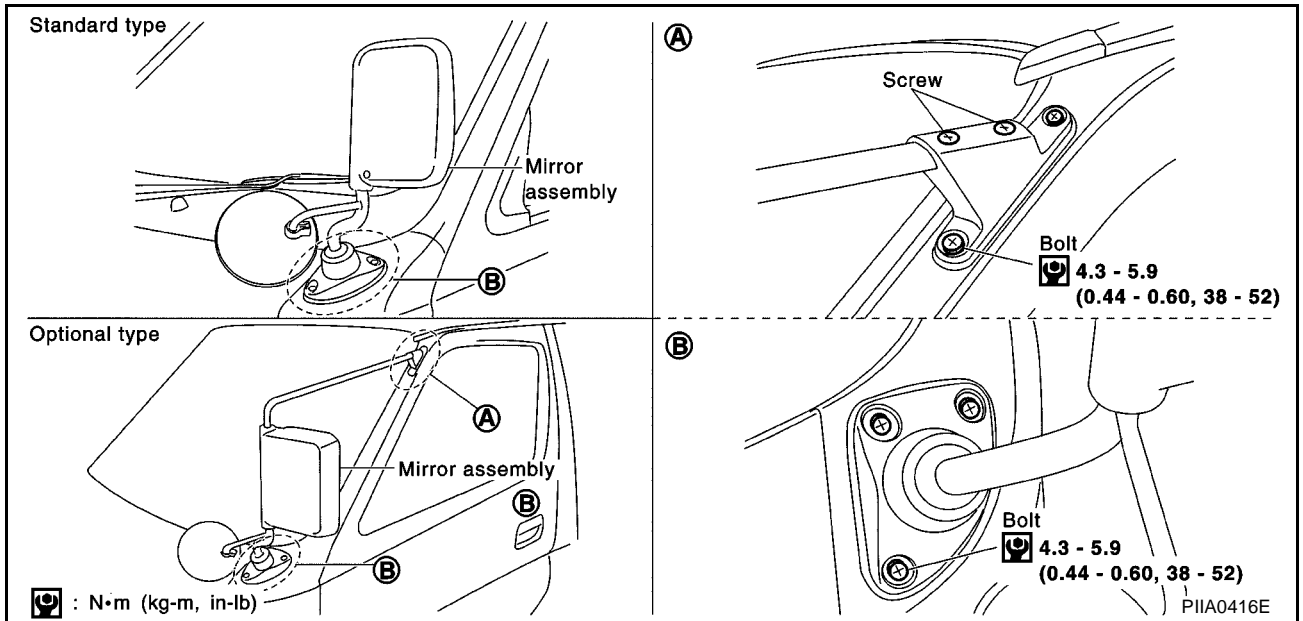

REAR UNDER MIRROR

REAR UNDER MIRROR Removal and Installation

PFP:96340

EIS00193

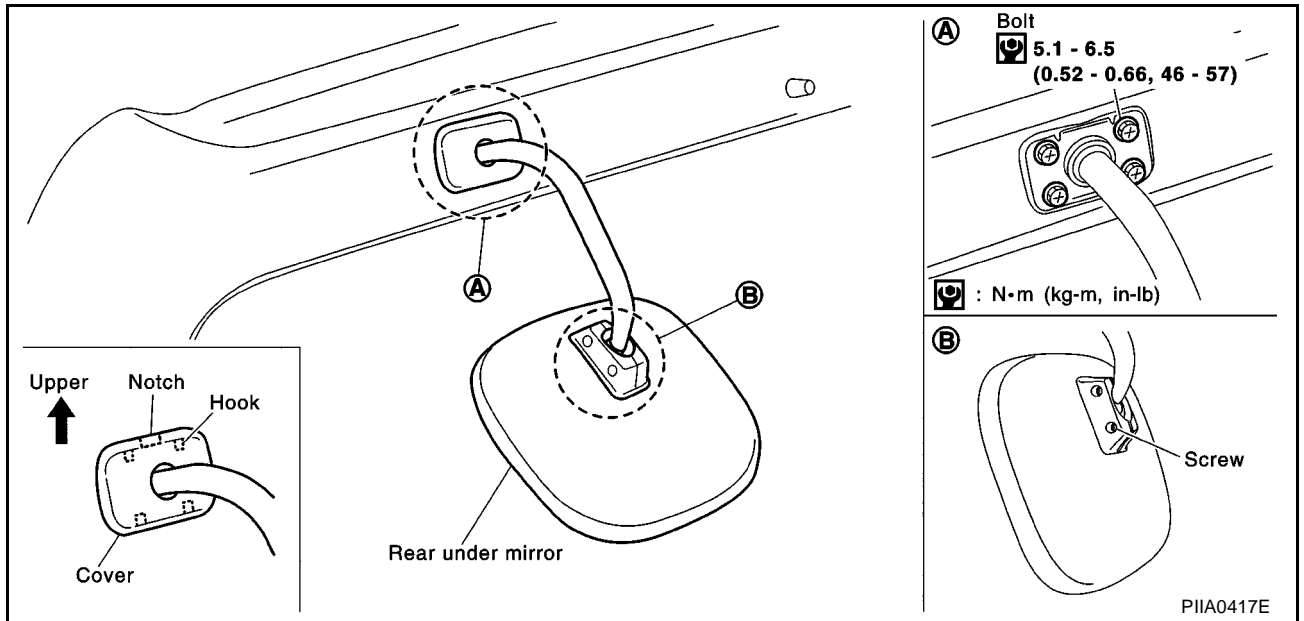

A
B
C
D
E
F
G
H
J
K
L
M

GW

REAR UNDER MIRROR
