

SERVICE MANUAL

MODEL
L14, L16 & L18 SERIES
ENGINES

NISSAN

NISSAN MOTOR CO., LTD.
TOKYO, JAPAN

SECTION EL

ENGINE LUBRICATION SYSTEM

EL

ENGINE LUBRICATION SYSTEM	EL- 2
SERVICE DATA AND SPECIFICATIONS	EL- 5
TROUBLE DIAGNOSES AND CORRECTIONS	EL- 5

ENGINE LUBRICATION SYSTEM

CONTENTS

LUBRICATION CIRCUIT	EL-2	Inspection	EL-3
OIL PUMP	EL-2	OIL PRESSURE REGULATOR VALVE	EL-4
Removal	EL-2	OIL FILTER	EL-4
Installation	EL-2	RELIEF VALVE	EL-4
Disassembly and assembly	EL-3		

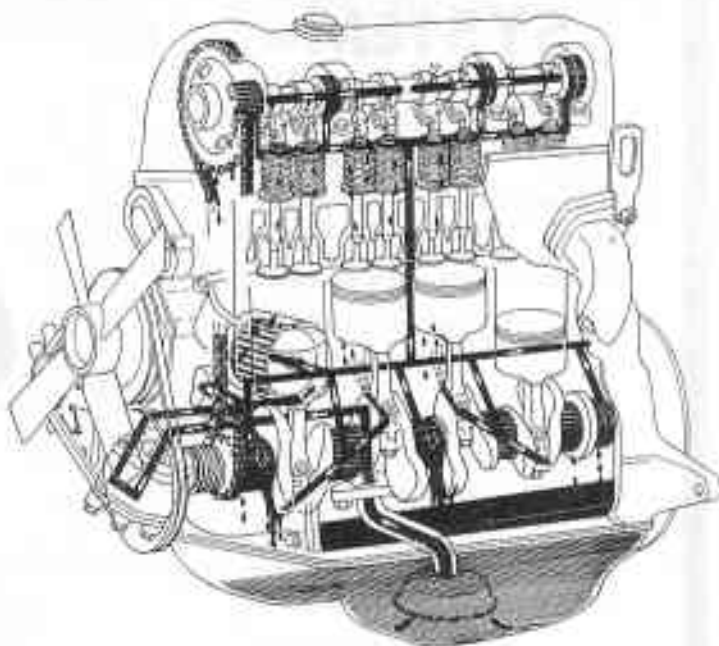

EL007

Fig. EL-1 Lubricating circuit

LUBRICATION CIRCUIT

The pressure lubrication of the engine is accomplished by a trochoid-type oil pump. This pump draws the oil through the oil strainer into pump housing and then forces it through the full flow type oil filter into the main oil gallery. Part of the oil is supplied to all crankshaft bearings, chain tensioner and timing chain. Oil supplied to crankshaft bearings is fed to connecting rod bearings through the drilled passages in the crankshaft. Oil injected from jet holes on connecting rods lubricates the cylinder walls and piston pins. The other part of the oil is brought to the oil gallery in the

cylinder head to provide lubrication of the valve mechanism and timing chain as shown in Figure EL-2.



EL008

Fig. EL-2 Lubricating cylinder head

From this gallery, oil holes go directly to all camshaft bearings through cam brackets.

Oil supplied through the No. 2 and No. 3 camshaft bearings is then fed to the rocker arm, valve and cam lobe through the oil gallery in the camshaft and the small channel at the base circle portion of each cam.

OIL PUMP

The oil pump is located in the bottom of the front cover by four bolts and driven by the oil pump drive spindle assembly which is driven by the helical gear on the crankshaft.

The oil pump assembly consists of an oil pressure regulator valve and outer and inner rotors.

The spring-loaded oil pressure regulator valve limits the oil pressure to a maximum of 5.6 kg/cm² (80 lb/sq in).

Removal

1. Remove distributor.
2. Drain engine oil.
3. Remove front stabilizer.
4. Remove splash shield board.
5. Remove oil pump body with drive spindle assembly.

Installation

1. Before installing oil pump in engine, turn crankshaft so that No. 1 piston is at T.D.C.

ENGINE LUBRICATION SYSTEM

2. Fill pump housing with engine oil, then align punch mark of spindle with hole in oil pump as shown in Figure EL-3.

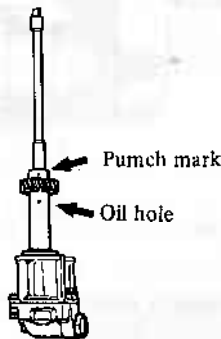

EL009
Fig. EL-3 Aligning punch mark and oil hole

3. Using a new gasket, install oil pump and drive spindle assembly so that the projection on its top is located in 11:25 a.m. position, at this time, the smaller bow-shape will be placed toward the front as shown in Figure EL-4.

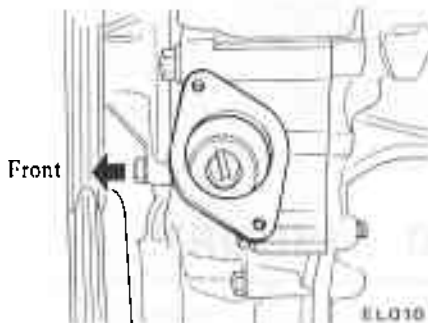

EL010
Fig. EL-4 Setting drive spindle

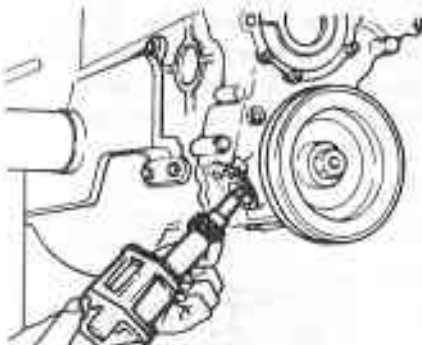

EL011
Fig. EL-5 Installing oil pump

As-certain whether the engagement is order or not by checking the top of

spindle through distributor fitting hole.
4. Tighten bolts securing oil pump to front cover.

Disassembly and assembly

1. Remove pump cover attaching bolts, pump cover and cover gasket, and slide out pump rotors.
2. Remove regulator cap, regulator valve and spring.
3. Install pressure regulator valve and related parts.
4. Install outer rotor, inner rotor and shaft in pump body and do not turn cover gasket up.

- 1 Oil pump body
- 2 Inner rotor and shaft
- 3 Outer rotor
- 4 Oil pump cover
- 5 Regulator valve
- 6 Regulator spring
- 7 Washer
- 8 Regulator cap
- 9 Cover gasket

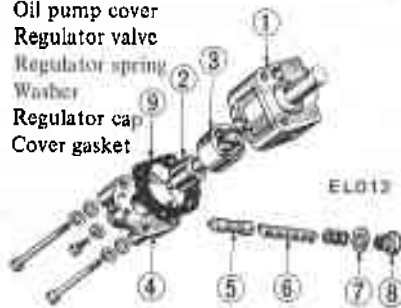

EL012
Fig. EL-6 Oil pump

Inspection

Wash all parts in cleaning solvent and dry with compressed air.

1. Inspect pump body and cover for cracks or excessive wear.
2. Inspect pump rotors for damage

- or excessive wear.
3. Check inner rotor shaft for looseness in pump body.
4. Inspect regulator valve for wear or scoring.
5. Check regulator spring to see that it is not worn on its side or collapsed.
6. Using a feeler gauge, check tip clearance and outer rotor-to-body clearances shown in Figure EL-7.

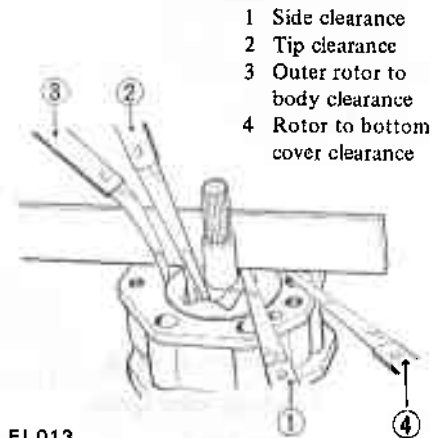

EL013
Fig. EL-7 Checking rotor clearances

7. Place a straight edge across the face of pump as shown in Figure EL-7. Check side clearance (outer to inner rotor) and gap between body and straight edge.

The gap should be -0.03 to 0.06 mm (-0.0012 to 0.0024 in), then rotor to bottom cover clearance with gasket should satisfy the specifications.

L14, L16 and L18		Standard	Wear limit
Rotor side clearance (outer to inner rotor)	mm (in)	0.05 to 0.12 (0.0020 to 0.0047)	0.20 (0.0079)
Rotor tip clearance	mm (in)	Less than 0.12 (0.0047)	0.20 (0.0079)
Outer rotor to body clearance	mm (in)	0.15 to 0.21 (0.0059 to 0.0083)	0.5 (0.0197)
Rotor to bottom cover clearance	mm (in)	0.03 to 0.13 (0.0012 to 0.0051)	0.20 (0.0079)

ENGINE LUBRICATION SYSTEM

Note: Pump rotors and body are not serviced separately. If pump rotors or body are damaged or worn, replacement of the entire oil pump assembly is necessary.

OIL PRESSURE REGULATOR VALVE

The oil pressure regulator valve is not adjustable. At the released position, the valve permits the oil to by-pass through the passage in the pump cover to the inlet side of the pump. Check regulator valve spring to ensure that spring tension is correct.

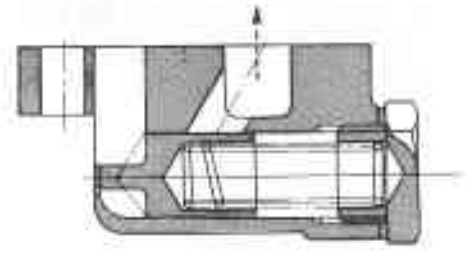

EL014

Fig. EL-8 Regulator valve

Tightening torque

Oil pump mounting bolts	kg-m (ft-lb)	1.1 to 1.5 (8.0 to 11)
Oil pump cover bolts	kg-m (ft-lb)	0.7 to 1.0 (5.1 to 7.2)
Cap nut-regulator valve	kg-m (ft-lb)	4 to 5 (29 to 26)

Specifications

Oil pressure at idling	kg/cm ² (lb/sq in)	0.8 to 2.8 (11 to 40)
Regulator valve spring		
Free length	mm (in)	52.5 (2.067)
Pressured length	mm (in)	34.8 (1.370)
Regulator valve opening pressure	kg/cm ² (lb/sq in)	3.5 to 5.0 (50 to 71)

OIL FILTER

The oil filter is of a cartridge type. The oil filter element should be replaced every 10,000 km (6,000 miles) of operation, with the use of special tool.

“Oil Filter Wrench”

ST19320000

When installing an oil filter, fasten it on cylinder block by hand.

Note Do not overtighten filter, or oil leakage may occur.

RELIEF VALVE

The relief valve located at the center portion securing oil filter in the cylinder block by-passes the oil into the main gallery when the oil filter element is excessively clogged.

With oil filter removed, check valve unit for operation. Inspect for a cracked or broken valve. If replacement is necessary, remove valve by prying it out with a screwdriver. Install a new valve in place by tapping it.

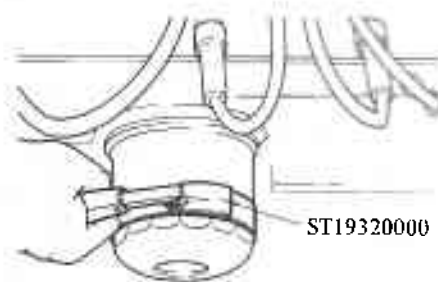

EL015

Fig. EL-9 Removing oil filter

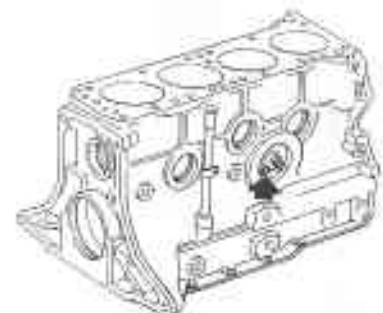

EL016

Fig. EL-10 Relief valve

ENGINE LUBRICATION SYSTEM

SERVICE DATA AND SPECIFICATIONS

Oil pump

		Standard	Wear limit
Rotor side clearance (outer to inner rotor)	mm (in)	0.05 to 0.12 (0.0020 to 0.0047)	0.20 (0.0079)
Rotor tip clearance	mm (in)	less than 0.12 (0.0047)	0.20 (0.0079)
Outer rotor to body clearance	mm (in)	0.15 to 0.21 (0.0059 to 0.0083)	0.5 (0.0197)
Rotor to bottom cover clearance	mm (in)	0.03 to 0.13 (0.0012 to 0.0051)	0.20 (0.0079)

Oil pressure regulator valve

Oil pressure at idling	kg/cm ² (lb/sq in)	0.8 to 2.8 (11 to 40)
Regulator valve spring:		
Free length	mm (in)	52.5 (2.067)
Pressured length	mm (in)	34.8 (1.370)
Regulator valve opening pressure	kg/cm ² (lb/sq in)	3.5 to 5.0 (50 to 71)
Tightening torque:		
Oil pump mounting bolts	kg-m (ft-lb)	1.1 to 1.5 (8.0 to 11)
Oil pump cover bolts	kg-m (ft-lb)	0.7 to 1.0 (5.1 to 7.2)
Regulator valve cap nut	kg-m (ft-lb)	4 to 5 (29 to 36)

TROUBLE DIAGNOSES AND CORRECTIONS

Condition	Probable causes	Corrective actions
Oil leakage	Damaged or cracked body cover. Oil leakage from gasket. Oil leakage from regulator valve. Oil leakage from blind plug.	Replace. Replace. Tighten or replace. Replace.
Decreased oil pressure	Leak of oil in engine oil pan. Dirty oil strainer. Damaged or worn pump rotors. Defective regulator. Use of poor quality engine oil.	Correct. Clean or replace. Replace. Replace. Replace.
Warning light remains "on"-engine running	Decreased oil pressure. Oil pressure switch unserviceable. Electrical fault.	Previously mentioned. Replace. Check circuit.
Noise	Excessive backlash in pump rotors.	Replace.