

# SECTION BR

## MODIFICATION NOTICE:

- Wiring Diagrams have been changed.
- Service data and specifications (SDS) has been changed.

## CONTENTS

<b>TROUBLE DIAGNOSES</b> .....	2	Diagnostic Procedure 2 (ABS actuator solenoid valve and solenoid valve relay) .....	21
Component Parts and Harness Connector		Diagnostic Procedure 3 (Motor relay or motor).....	23
Location .....	2	Diagnostic Procedure 4 (Low voltage) .....	25
Schematic/2WD Models .....	3	Diagnostic Procedure 5 (G sensor).....	26
Wiring Diagram - ABS -/2WD LHD Models.....	4	Diagnostic Procedure 6 (Control unit) .....	27
Wiring Diagram - ABS -/2WD RHD Models .....	7	<b>TROUBLE DIAGNOSES FOR SYMPTOMS</b> .....	28
Schematic/4WD Models .....	10	Diagnostic Procedure 12 (Warning lamp does not come on when ignition switch is turned ON.) .....	28
Wiring Diagram - ABS -/4WD LHD Models.....	11	Diagnostic Procedure 13 (Warning lamp stays on when ignition switch is turned ON.).....	30
Wiring Diagram - ABS -/4WD RHD Models .....	15	<b>SERVICE DATA AND SPECIFICATIONS (SDS)</b> .....	31
<b>TROUBLE DIAGNOSES FOR SELF-DIAGNOSTIC ITEMS</b> .....	19	General Specifications.....	31
Diagnostic Procedure 1 (Wheel sensor or rotor) .....	19		

# TROUBLE DIAGNOSES

## Component Parts and Harness Connector Location

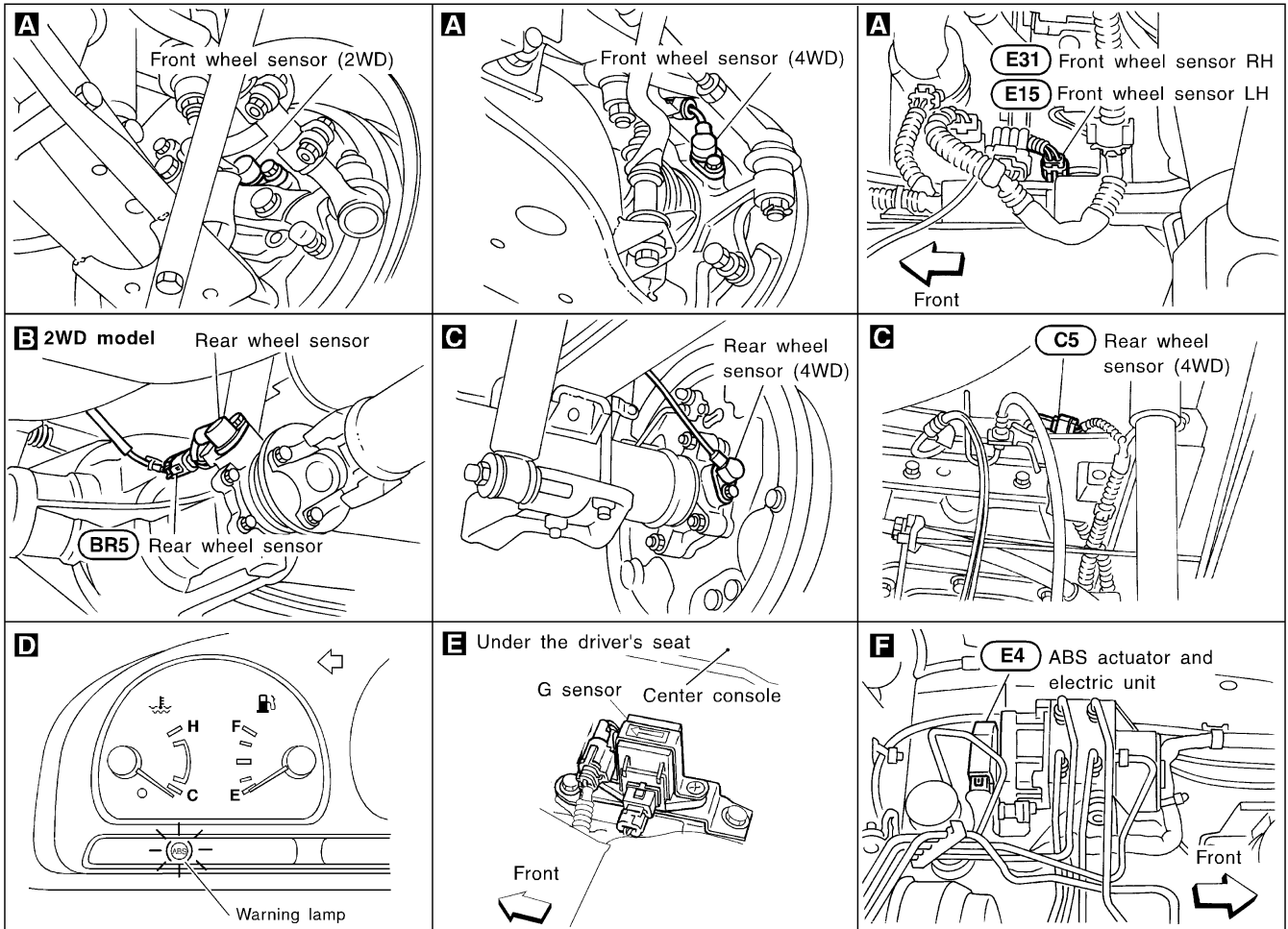
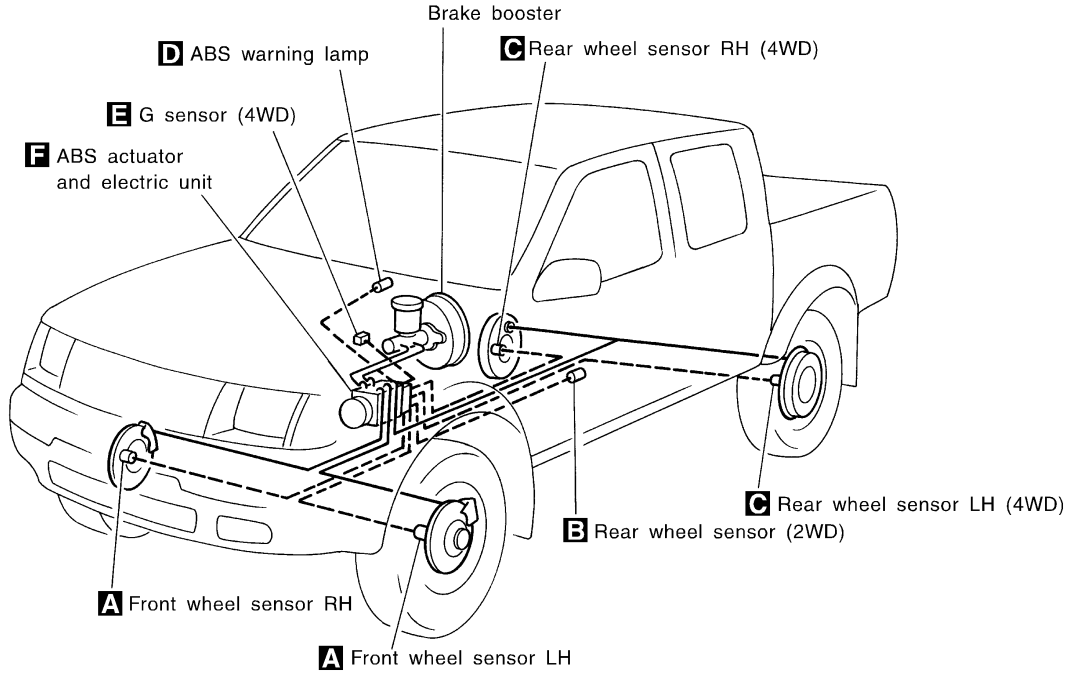

## Schematic/2WD Models

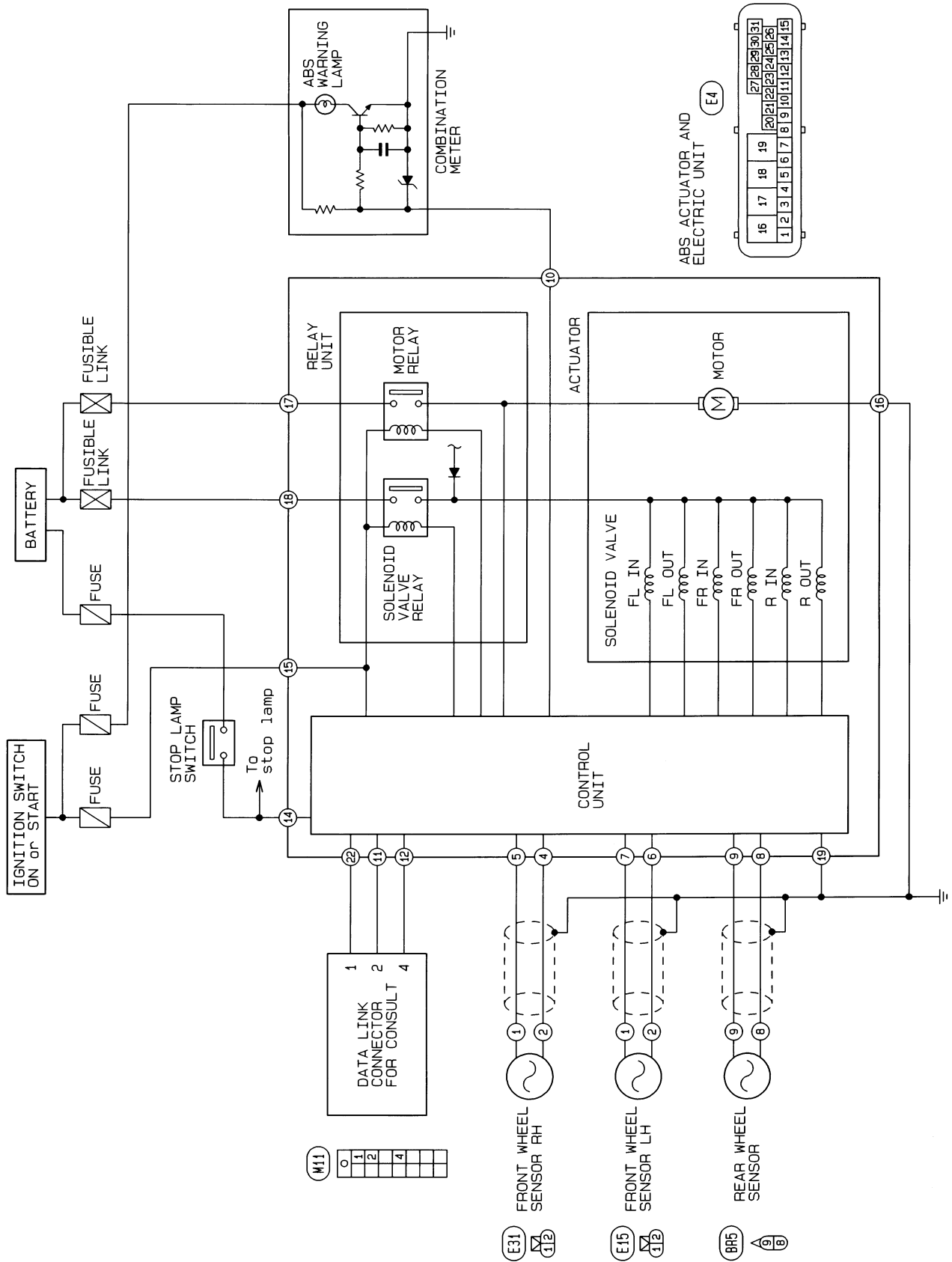

GI  
MA  
EM  
LC  
EC  
FE  
CL  
MT  
AT  
TF  
PD  
FA  
RA  
**BR**  
ST  
RS  
BT  
HA  
EL  
IDX

# TROUBLE DIAGNOSES

## Wiring Diagram — ABS —/2WD LHD Models

BR-ABS-01

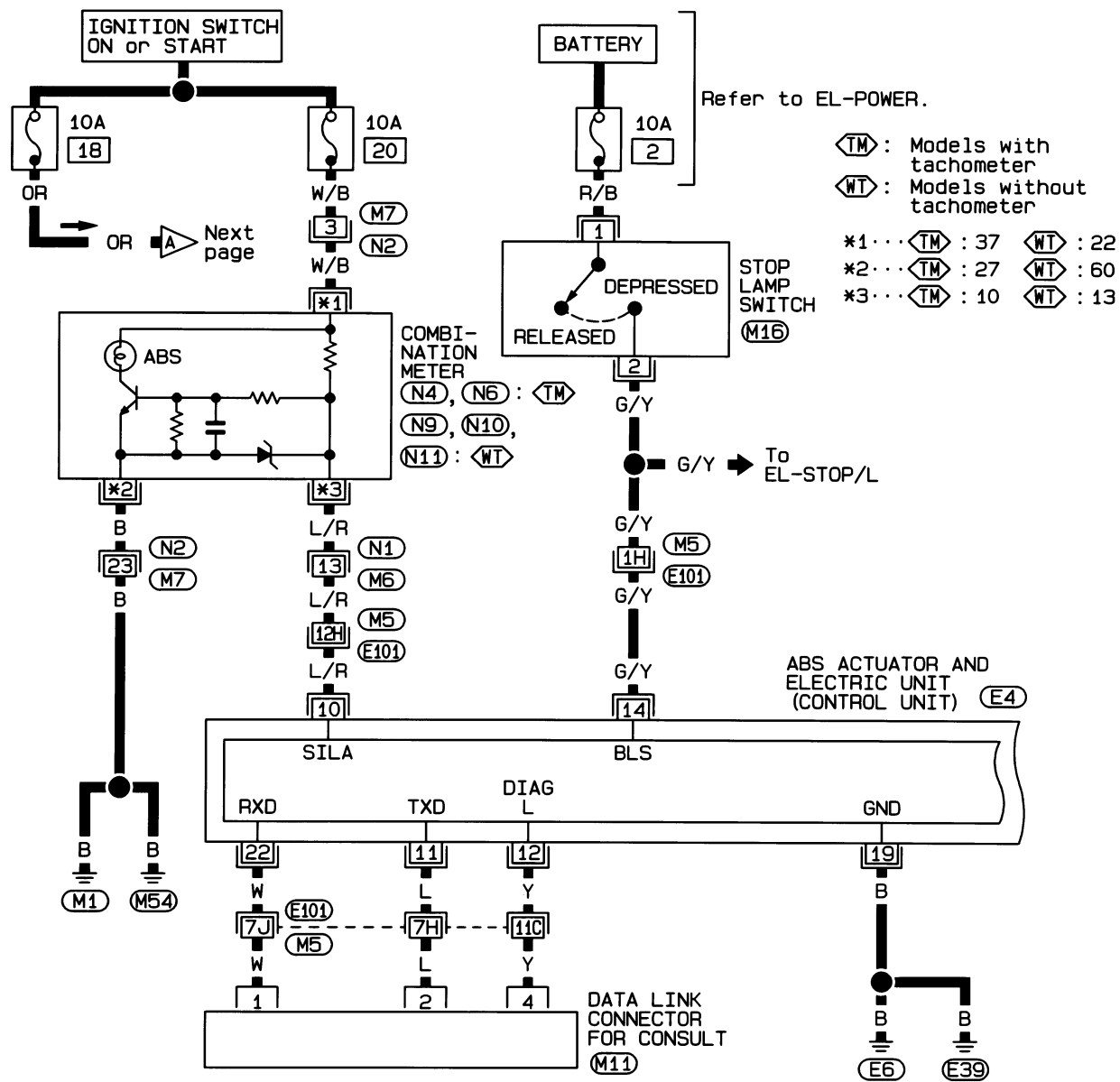

1 2 M16 1 2 3 4 5 6 7 8 9 10 N1 1 2 3 4 5 6 7 8 9 10 11 N2 Refer to last page (Foldout page).

11 12 13 14 15 16 17 18 19 20 21 22 23 24 W 12 13 14 15 16 17 18 19 20 21 22 23 24 BR

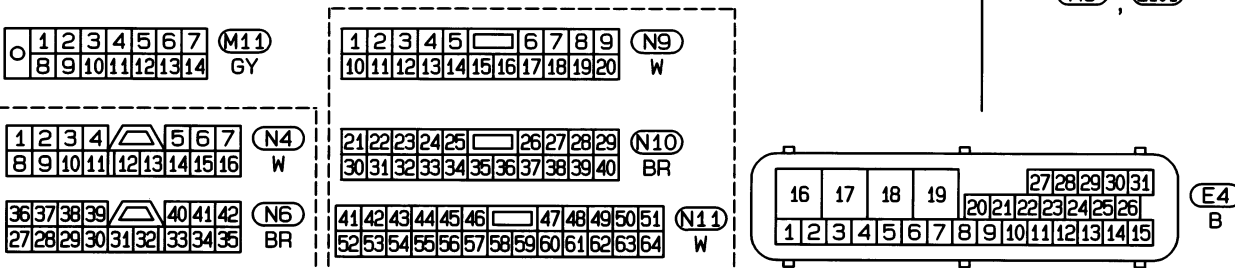



# TROUBLE DIAGNOSES

## Wiring Diagram — ABS —/2WD LHD Models (Cont'd)

BR-ABS-03

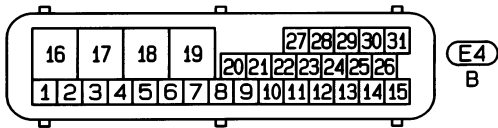
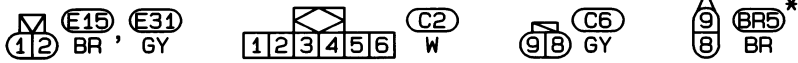
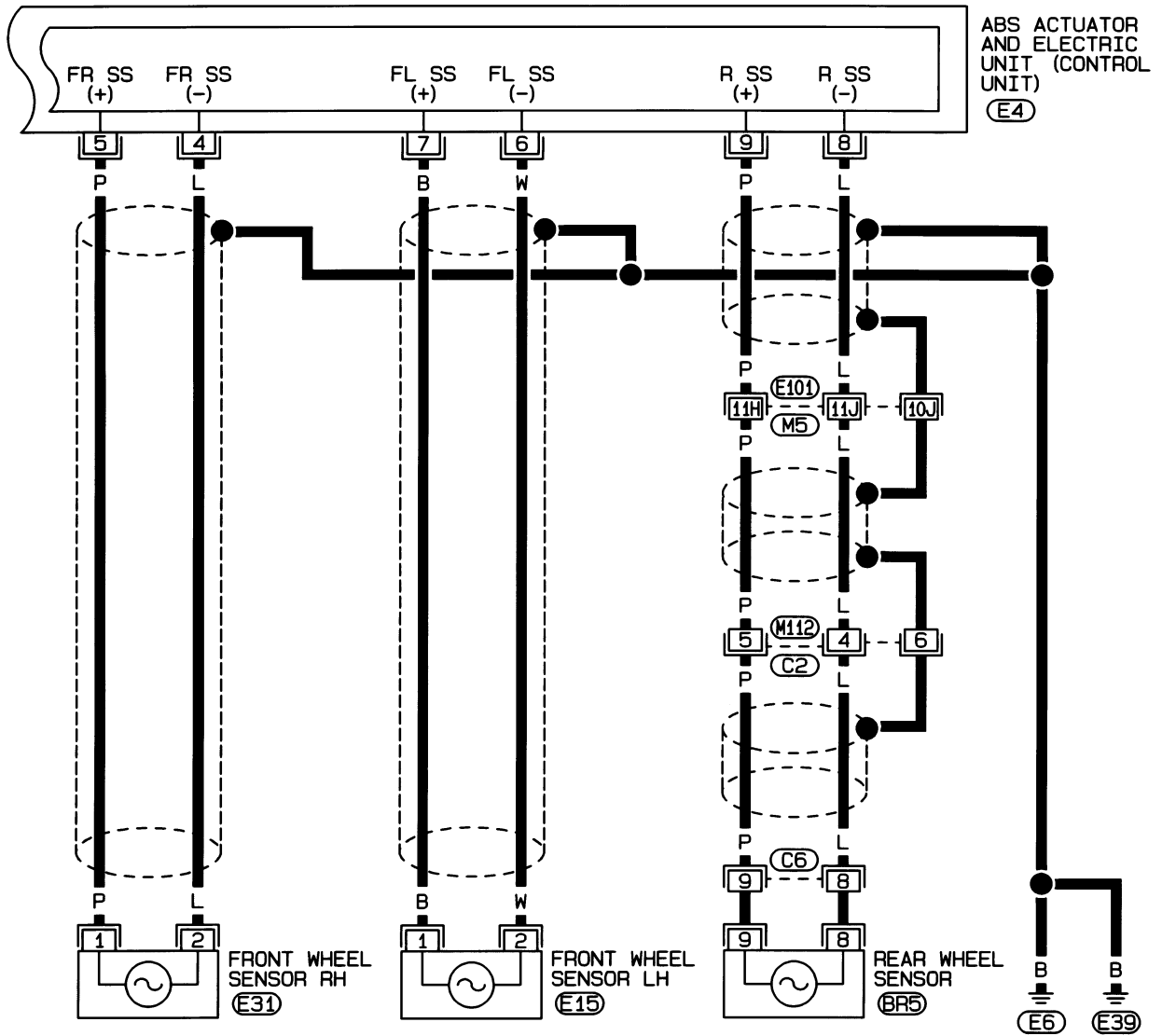

Refer to last page  
(Foldout page).

(M5), (E101)

\* : This connector is not shown in "HARNESS LAYOUT", EL section.

# TROUBLE DIAGNOSES

## Wiring Diagram — ABS —/2WD RHD Models

BR-ABS-04

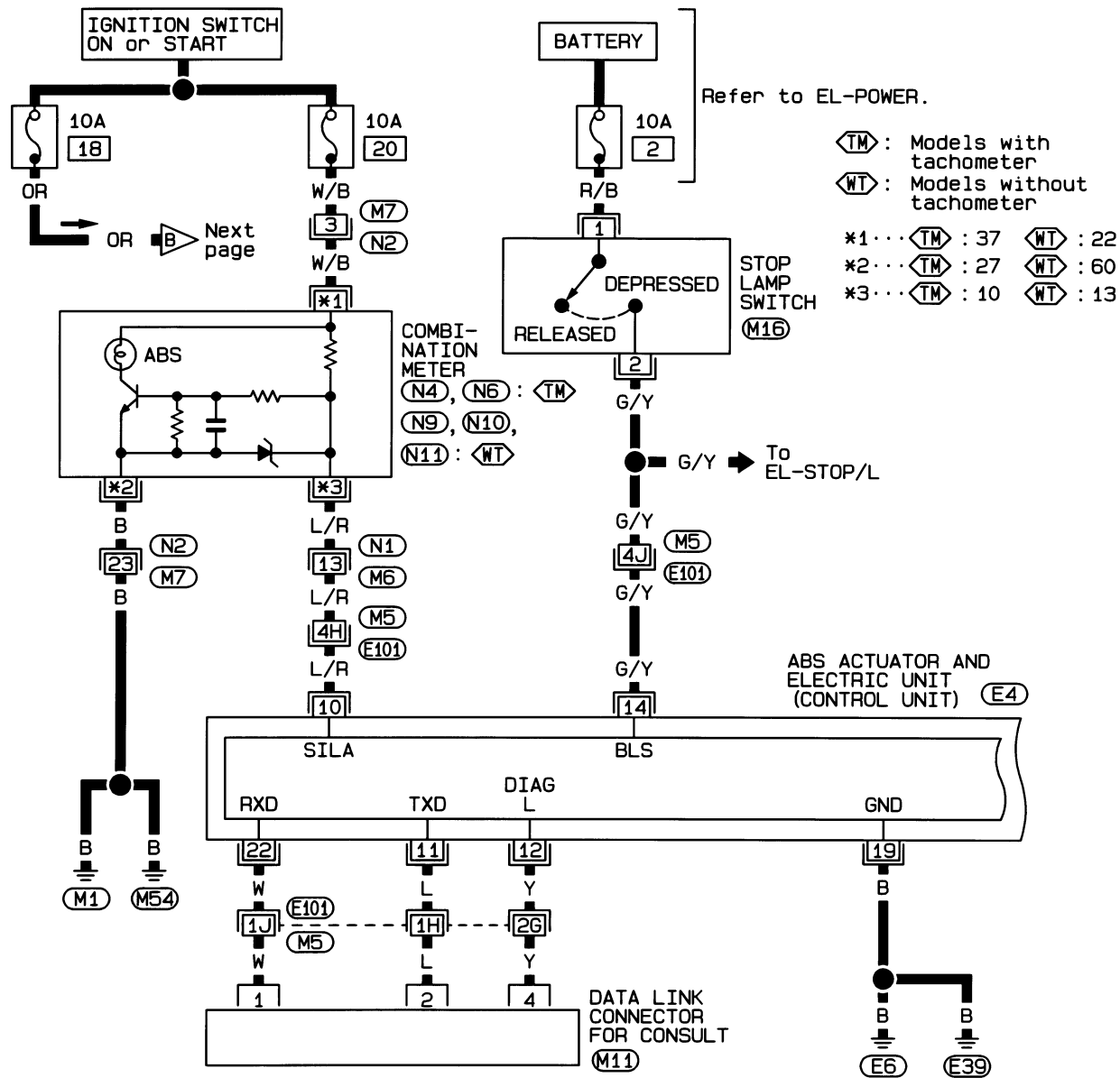

- Refer to EL-POWER.
- ◊TM: Models with tachometer
  - ◊WT: Models without tachometer
- \*1... ◊TM : 37    ◊WT : 22
  - \*2... ◊TM : 27    ◊WT : 60
  - \*3... ◊TM : 10    ◊WT : 13

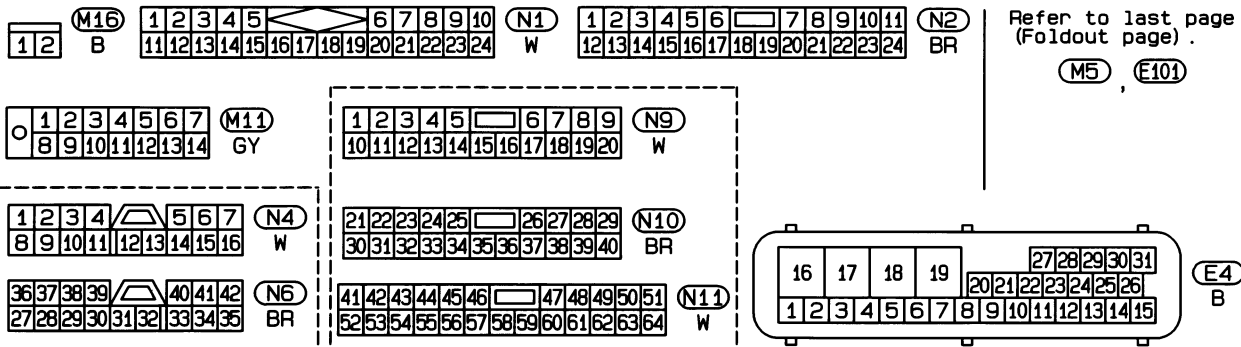

# TROUBLE DIAGNOSES

## Wiring Diagram — ABS —/2WD RHD Models (Cont'd)

BR-ABS-05

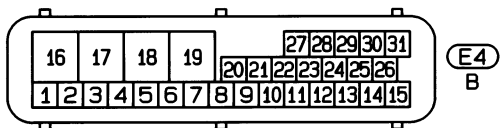
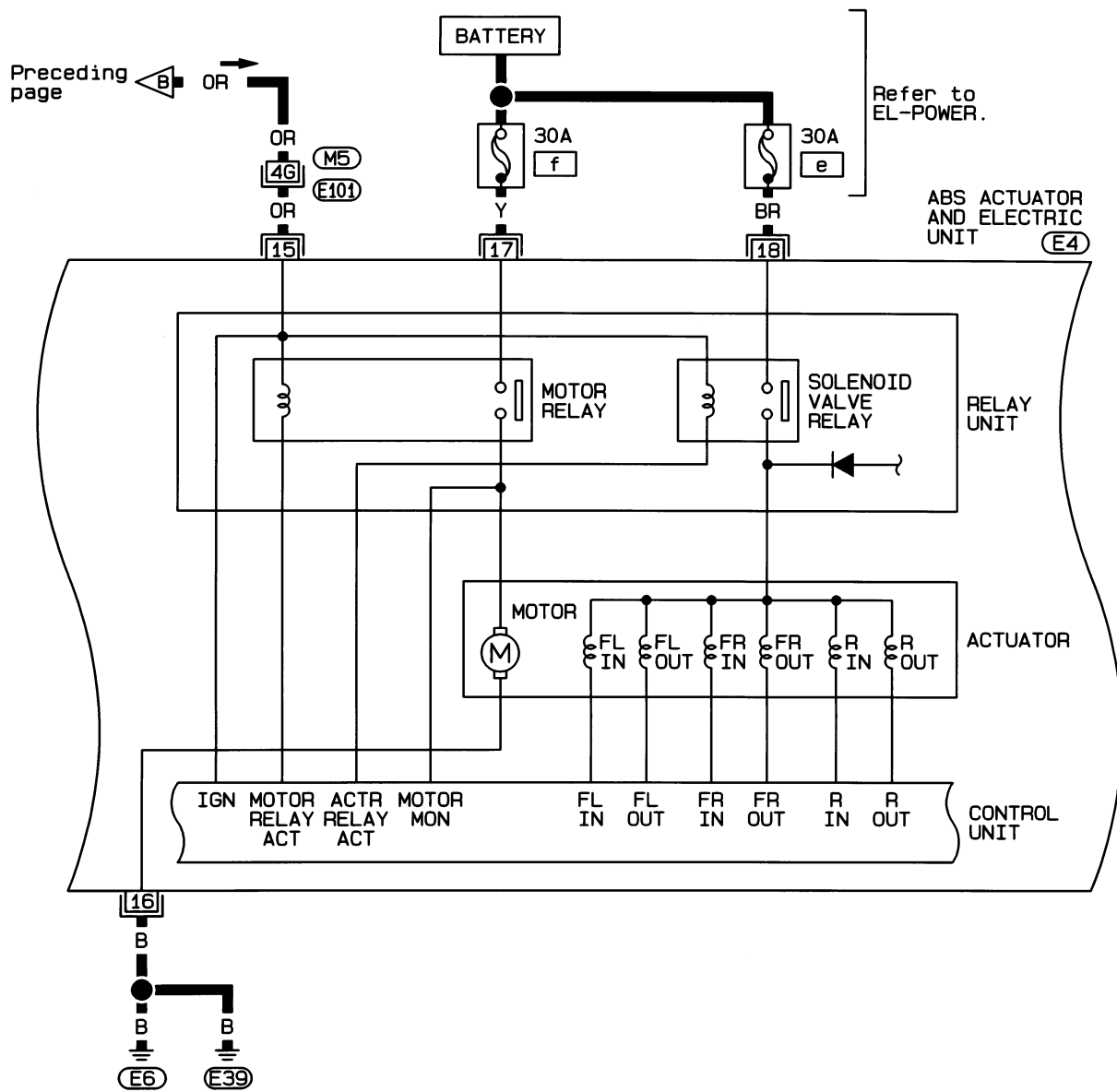

Refer to last page  
(Foldout page).

M5, E101



# TROUBLE DIAGNOSES

## Wiring Diagram — ABS —/2WD RHD Models (Cont'd)

BR-ABS-06

GI

MA

EM

LC

EC

FE

CL

MT

AT

TF

PD

FA

RA

**BR**

ST

RS

BT

HA

EL

IDX

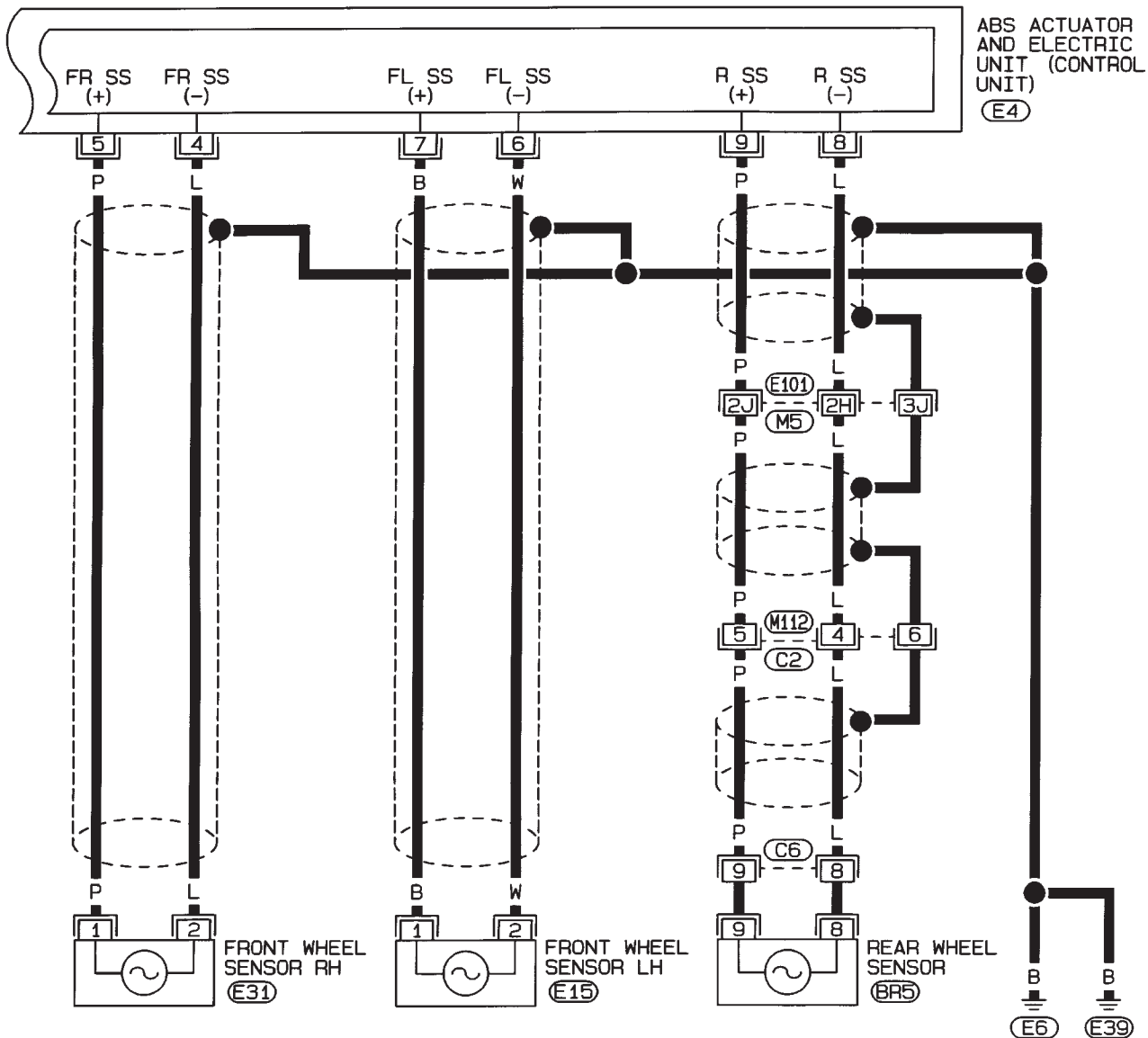

Refer to last page (Foldout page).

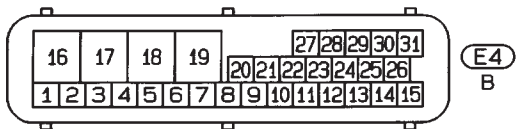

\* : This connector is not shown in "HARNESS LAYOUT", EL section.

Schematic/4WD Models

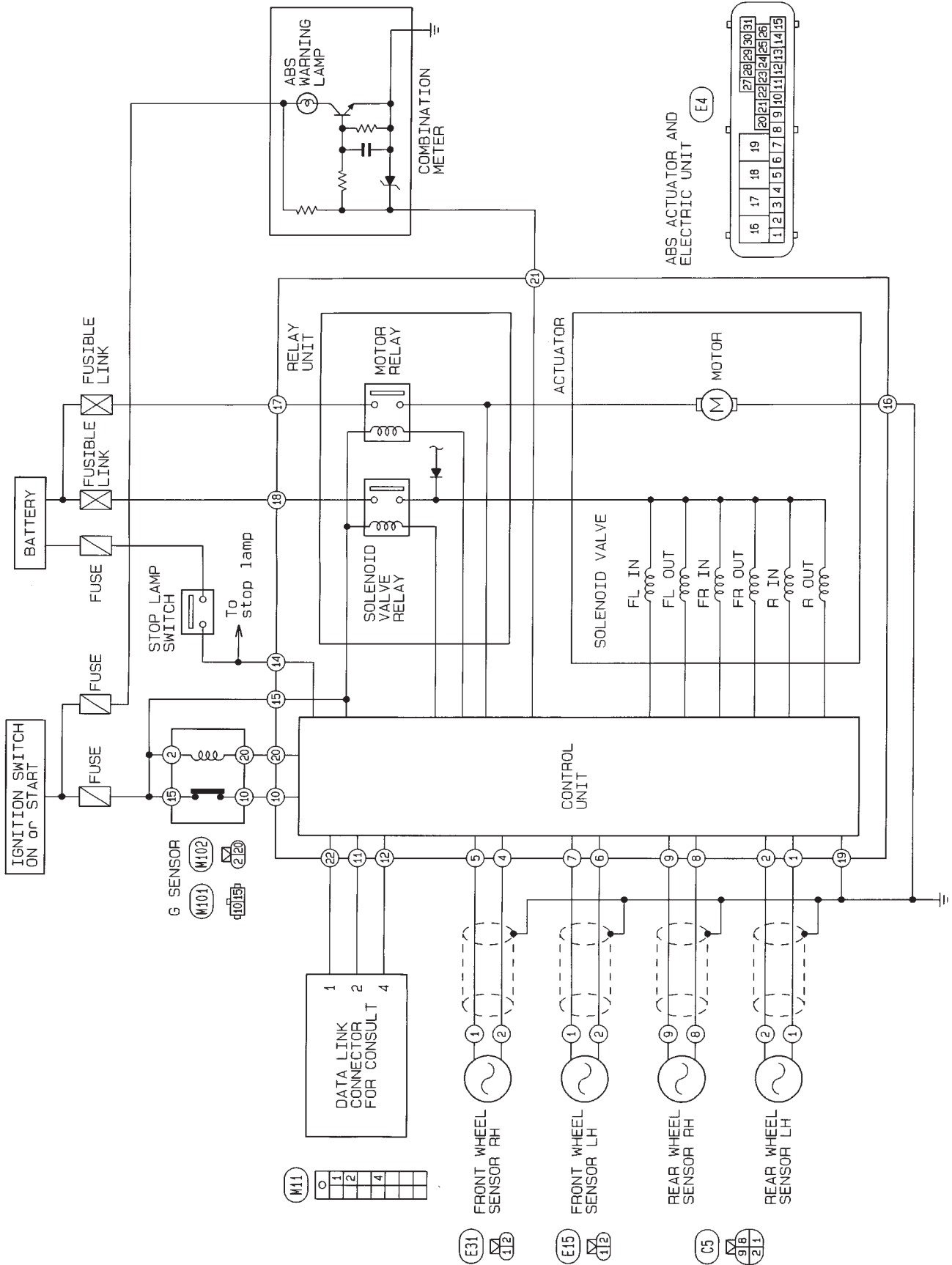

# TROUBLE DIAGNOSES

## Wiring Diagram — ABS —/4WD LHD Models

BR-ABS-07

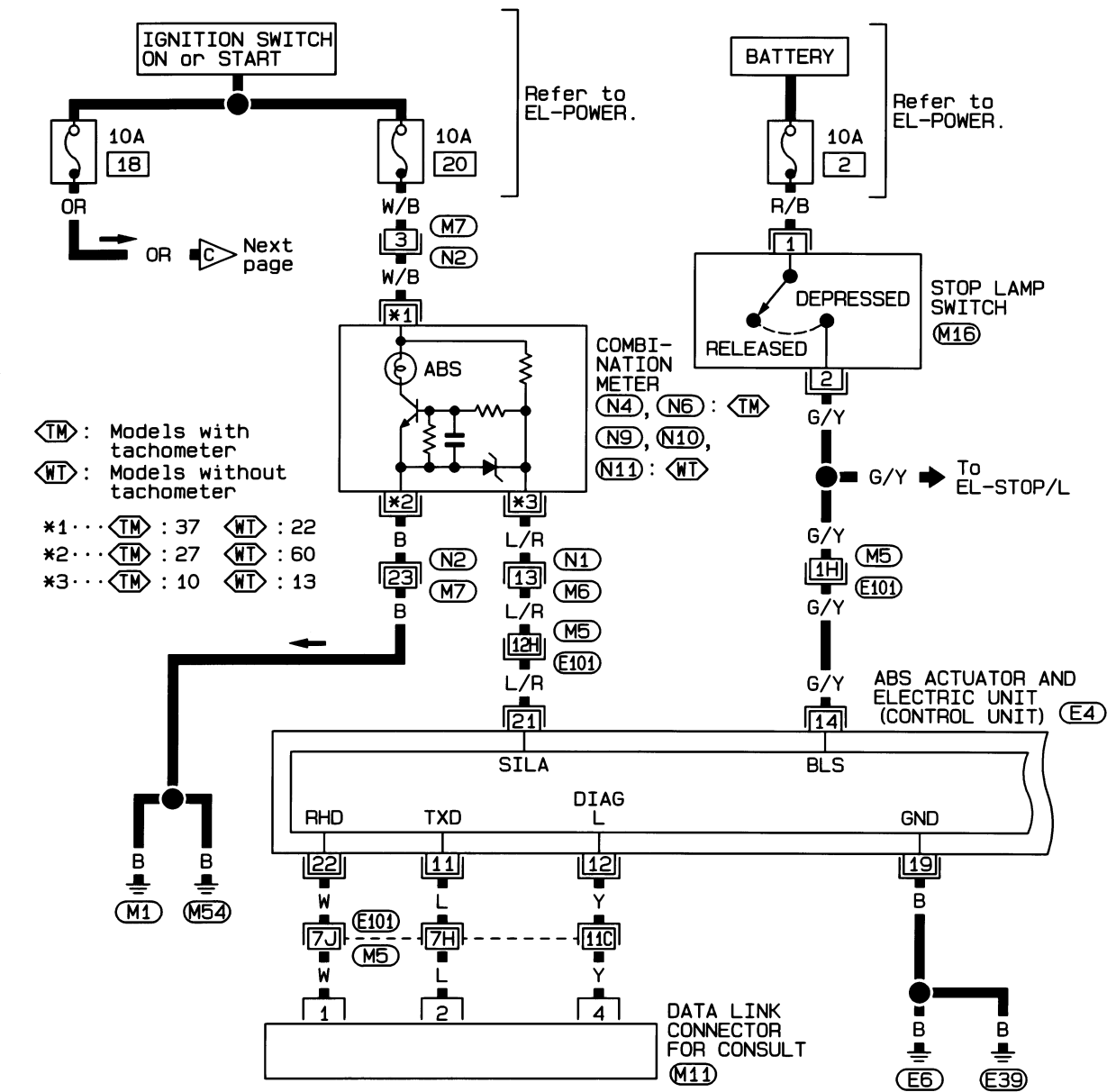

- Ⓜ: Models with tachometer
- Ⓦ: Models without tachometer
- \*1... Ⓜ : 37    Ⓦ : 22
- \*2... Ⓜ : 27    Ⓦ : 60
- \*3... Ⓜ : 10    Ⓦ : 13

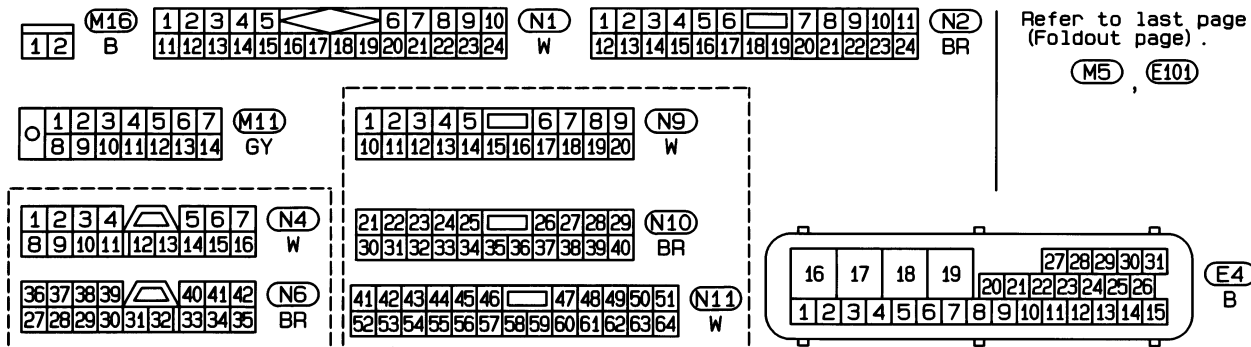

# TROUBLE DIAGNOSES

## Wiring Diagram — ABS —/4WD LHD Models (Cont'd)

BR-ABS-08

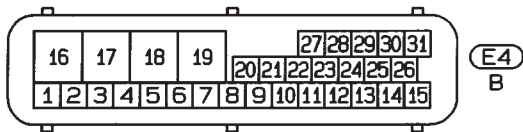
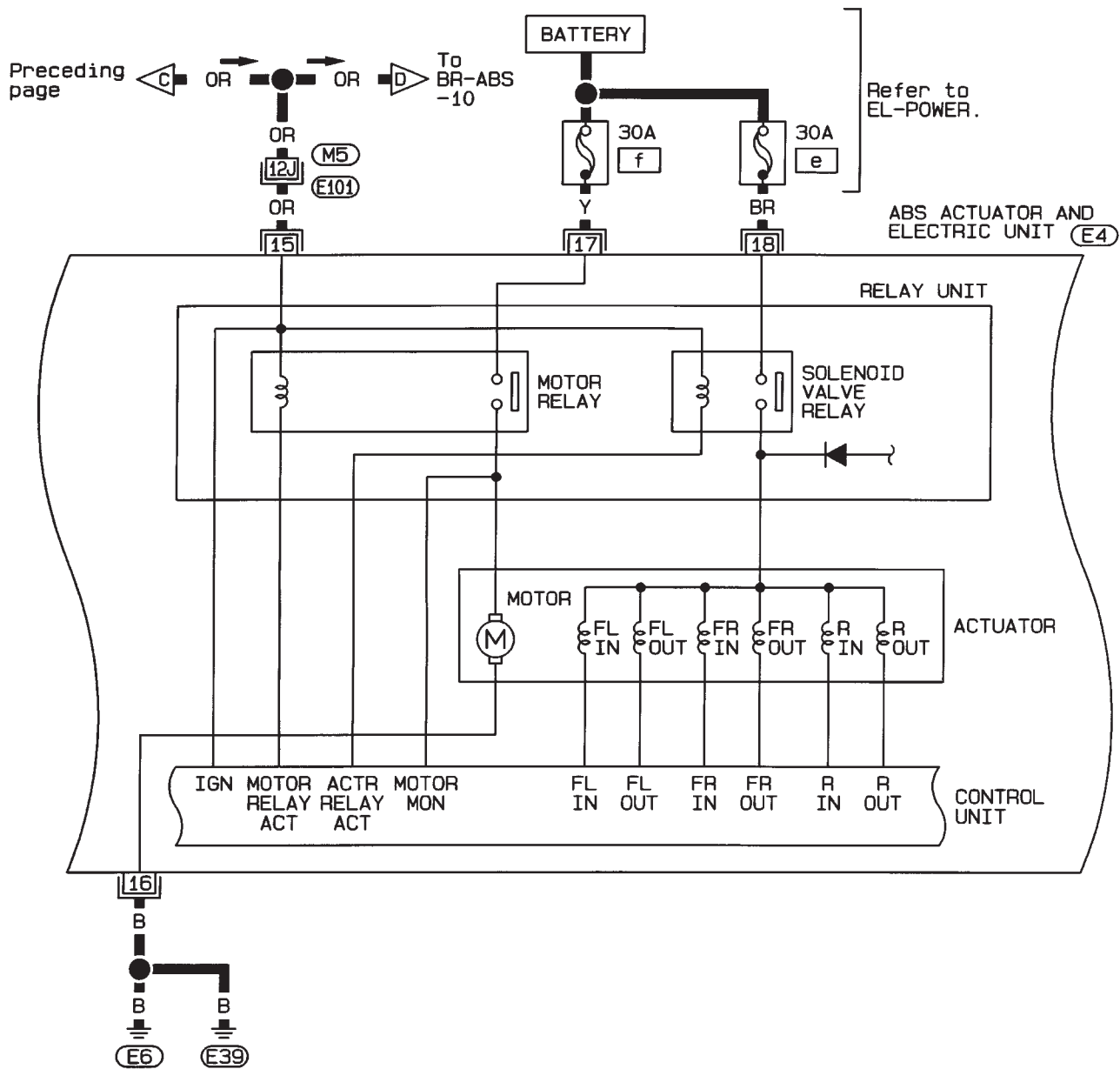

Refer to last page  
(Foldout page).

(M5), (E101)

# TROUBLE DIAGNOSES

## Wiring Diagram — ABS —/4WD LHD Models (Cont'd)

BR-ABS-09

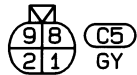
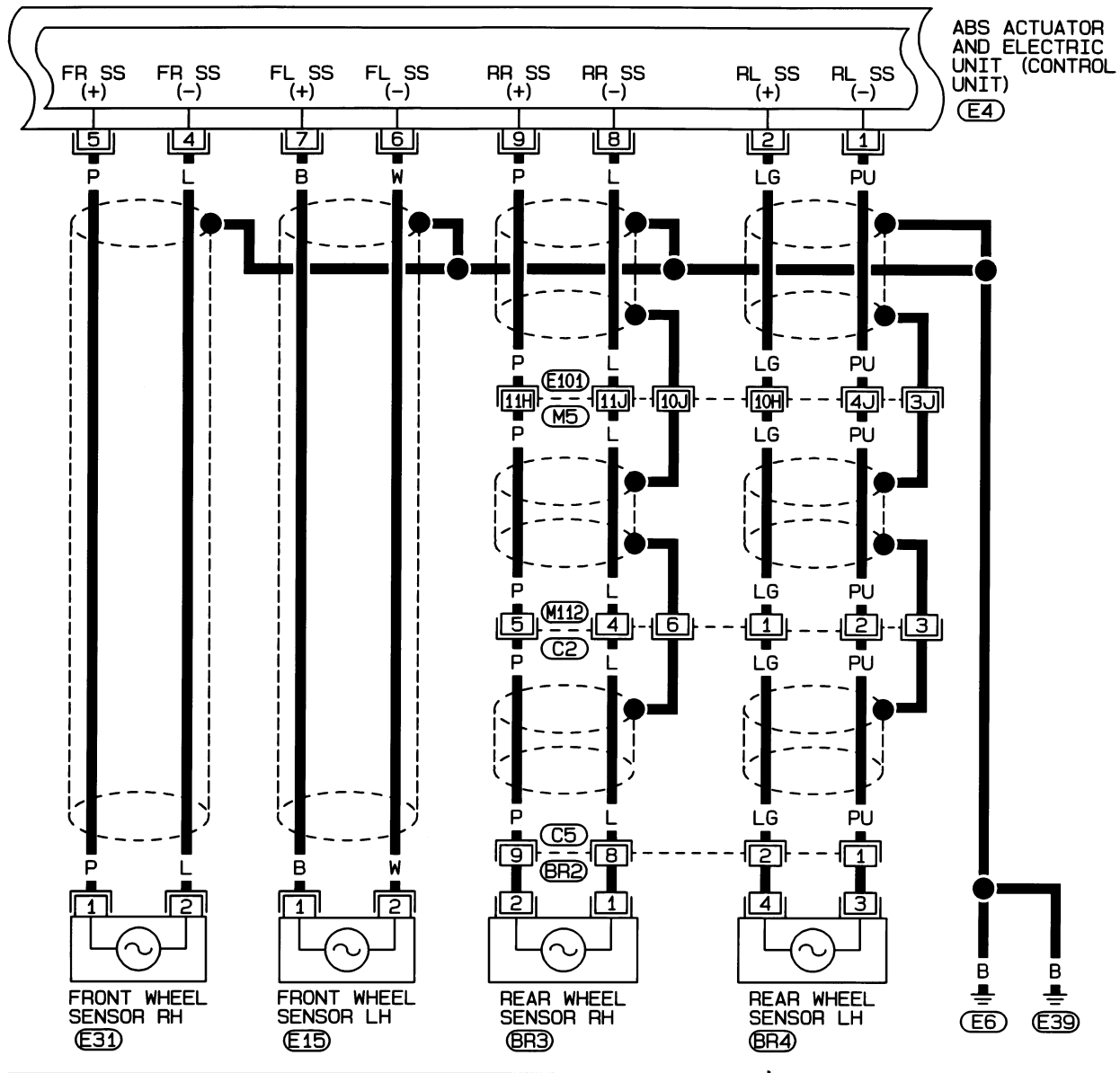

Refer to last page (Foldout page).

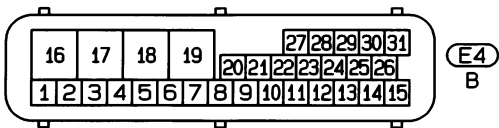

\* : This connector is not shown in "HARNESS LAYOUT", EL section.

GI  
MA  
EM  
LC  
EC  
FE  
CL  
MT  
AT  
TF  
PD  
FA  
RA  
BR  
ST  
RS  
BT  
HA  
EL  
IDX

# TROUBLE DIAGNOSES

## Wiring Diagram — ABS —/4WD LHD Models (Cont'd)

BR-ABS-10

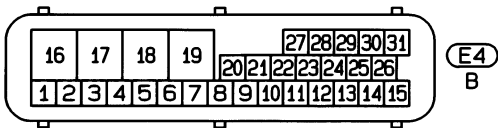
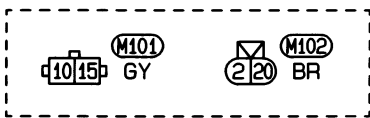
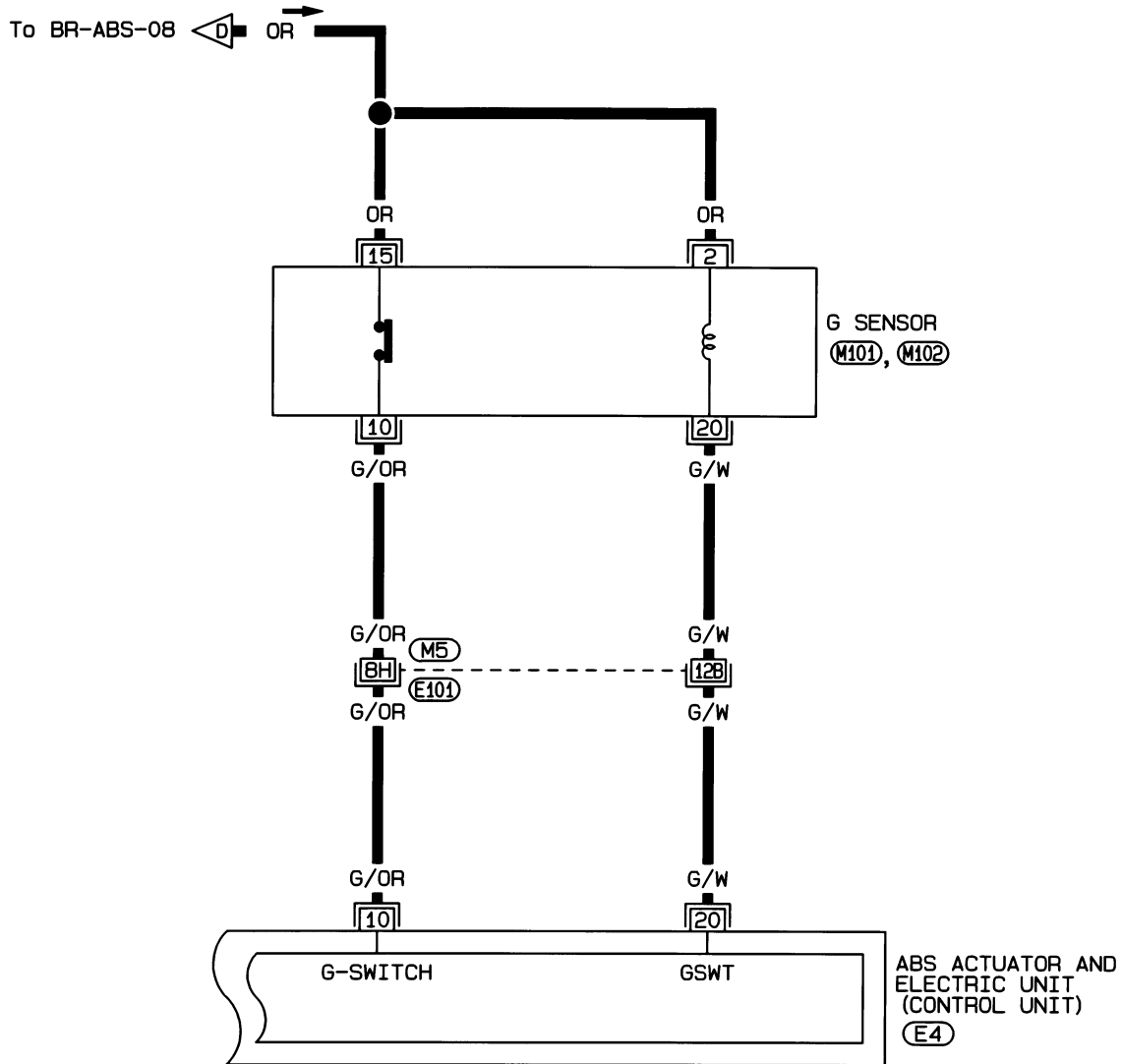

Refer to last page  
(Foldout page).

(M5), (E101)

# TROUBLE DIAGNOSES

## Wiring Diagram — ABS —/4WD RHD Models

BR-ABS-11

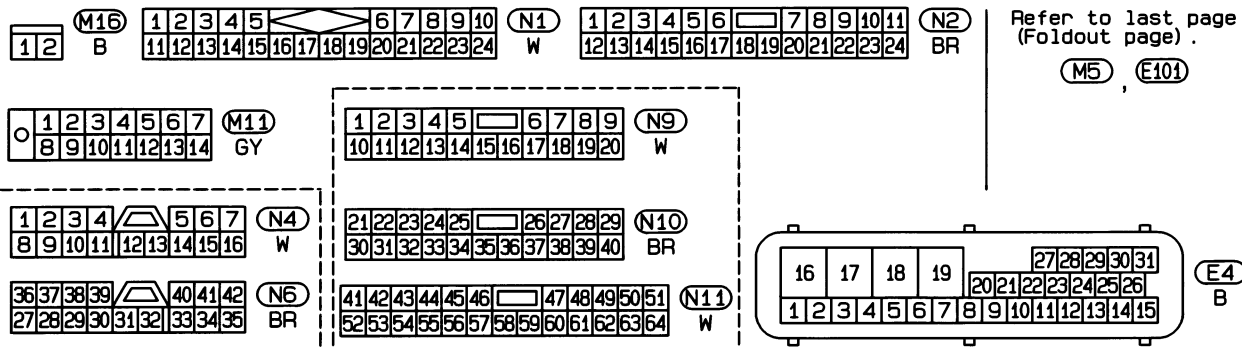
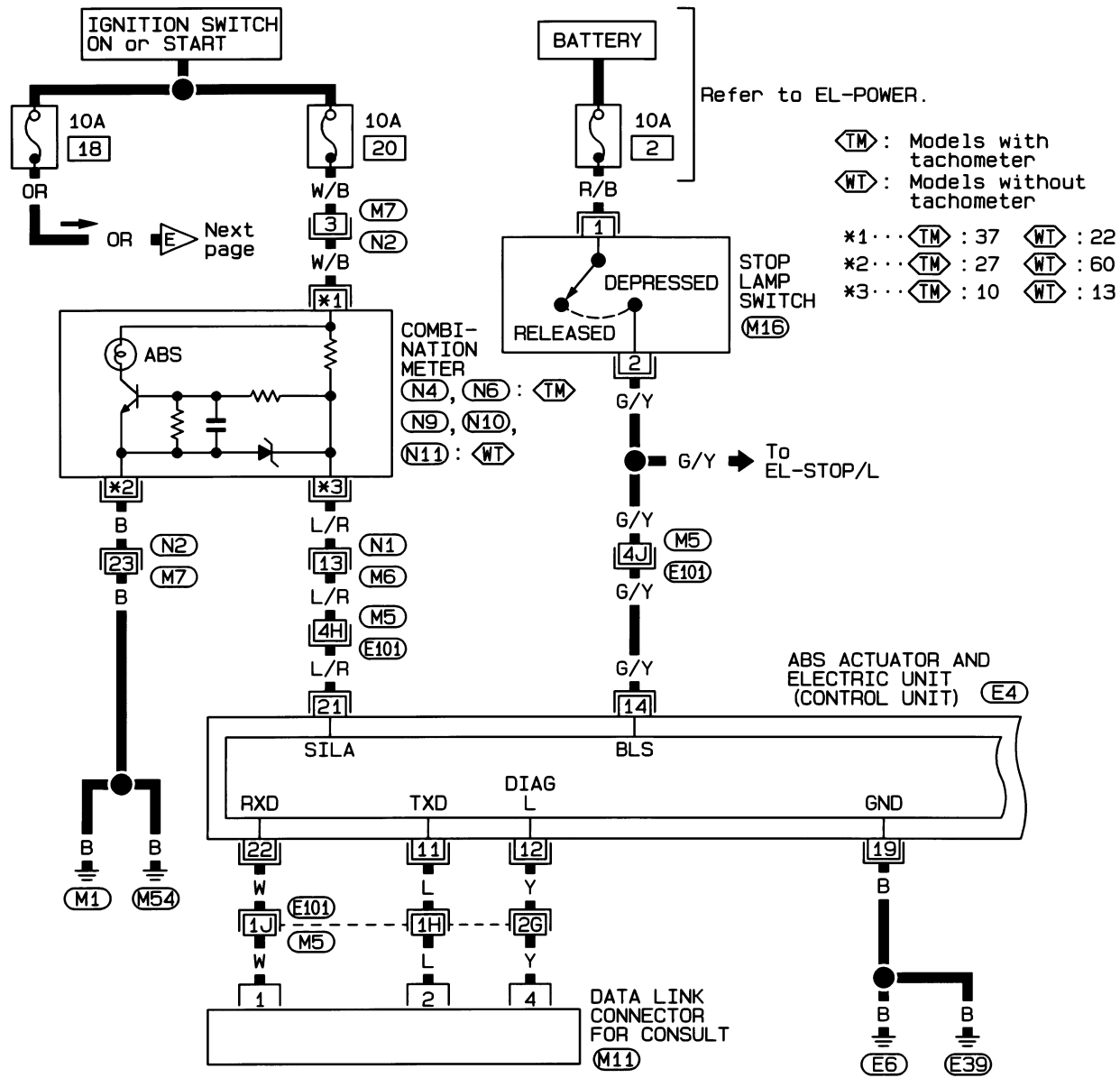

# TROUBLE DIAGNOSES

## Wiring Diagram — ABS —/4WD RHD Models (Cont'd)

BR-ABS-12

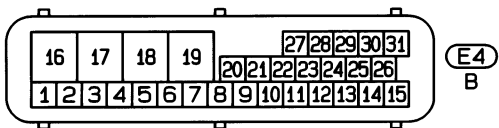
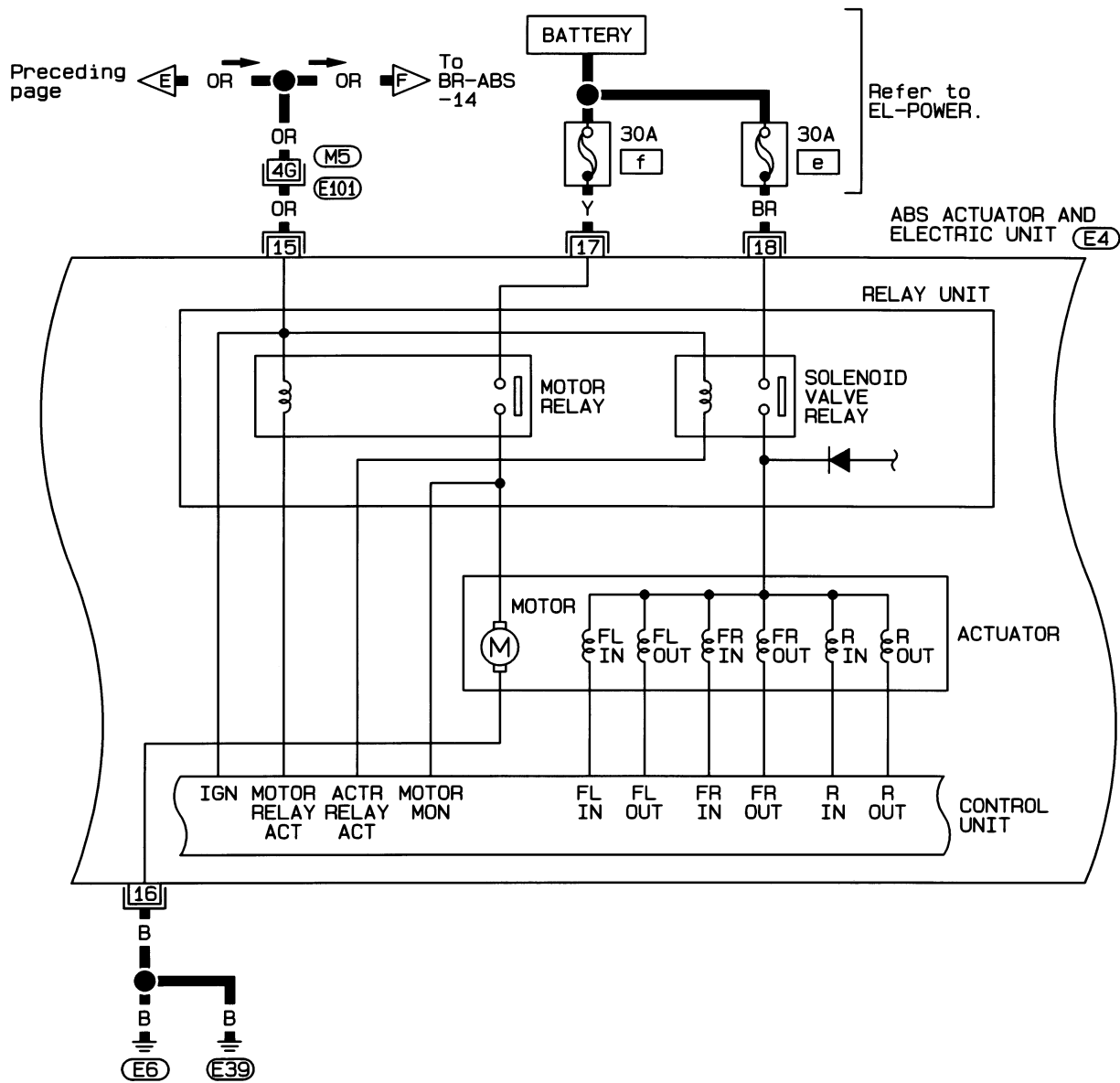

Refer to last page  
(Foldout page).

(M5), (E101)



# TROUBLE DIAGNOSES

## Wiring Diagram — ABS —/4WD RHD Models (Cont'd)

BR-ABS-13

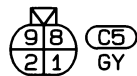
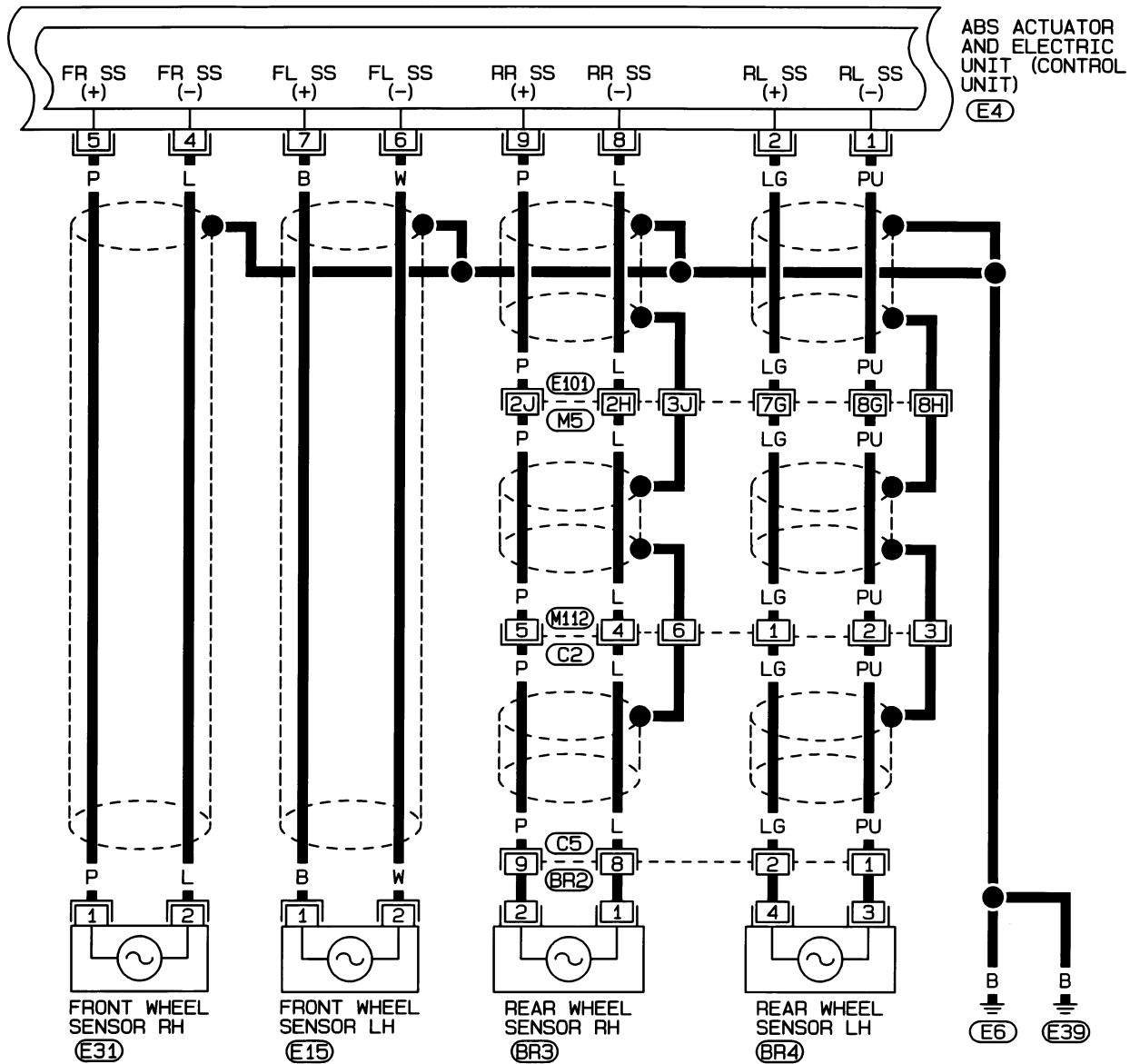

Refer to last page (Foldout page).

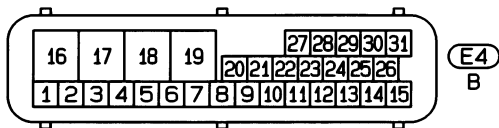

\* : This connector is not shown in "HARNESS LAYOUT", EL section.

GI

MA

EM

LC

EC

FE

CL

MT

AT

TF

PD

FA

RA

**BR**

ST

RS

BT

HA

EL

IDX

# TROUBLE DIAGNOSES

## Wiring Diagram — ABS —/4WD RHD Models (Cont'd)

BR-ABS-14

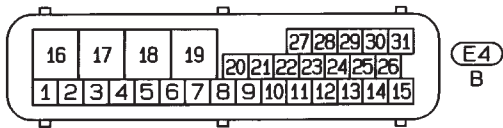
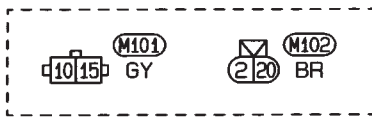
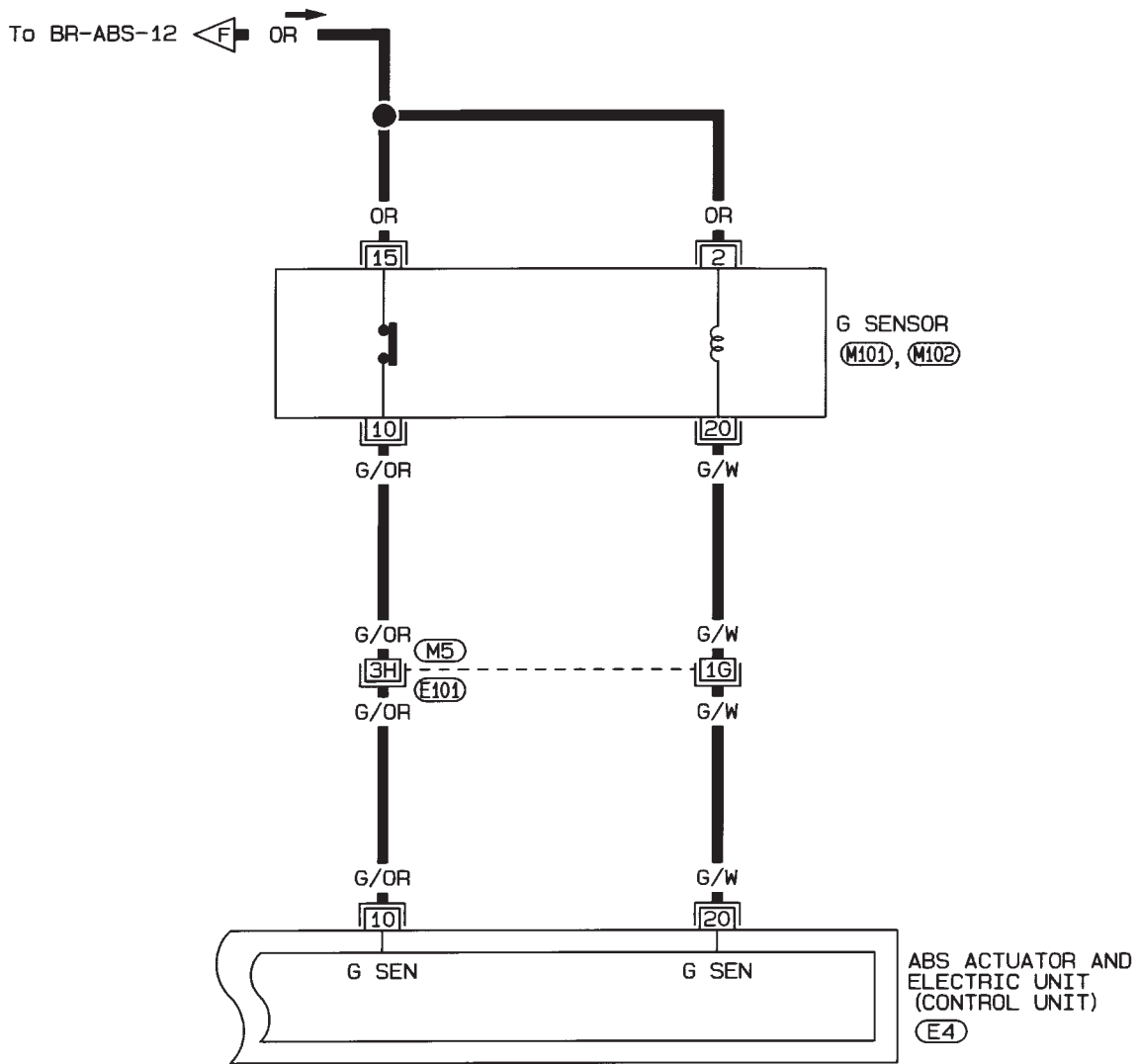

Refer to last page  
(Foldout page).

M5, E101

# TROUBLE DIAGNOSES FOR SELF-DIAGNOSTIC ITEMS

## Diagnostic Procedure 1 (Wheel sensor or rotor)

Malfunction code No. 21, 22, 25, 26, 31, 32, 35, 36 or 18

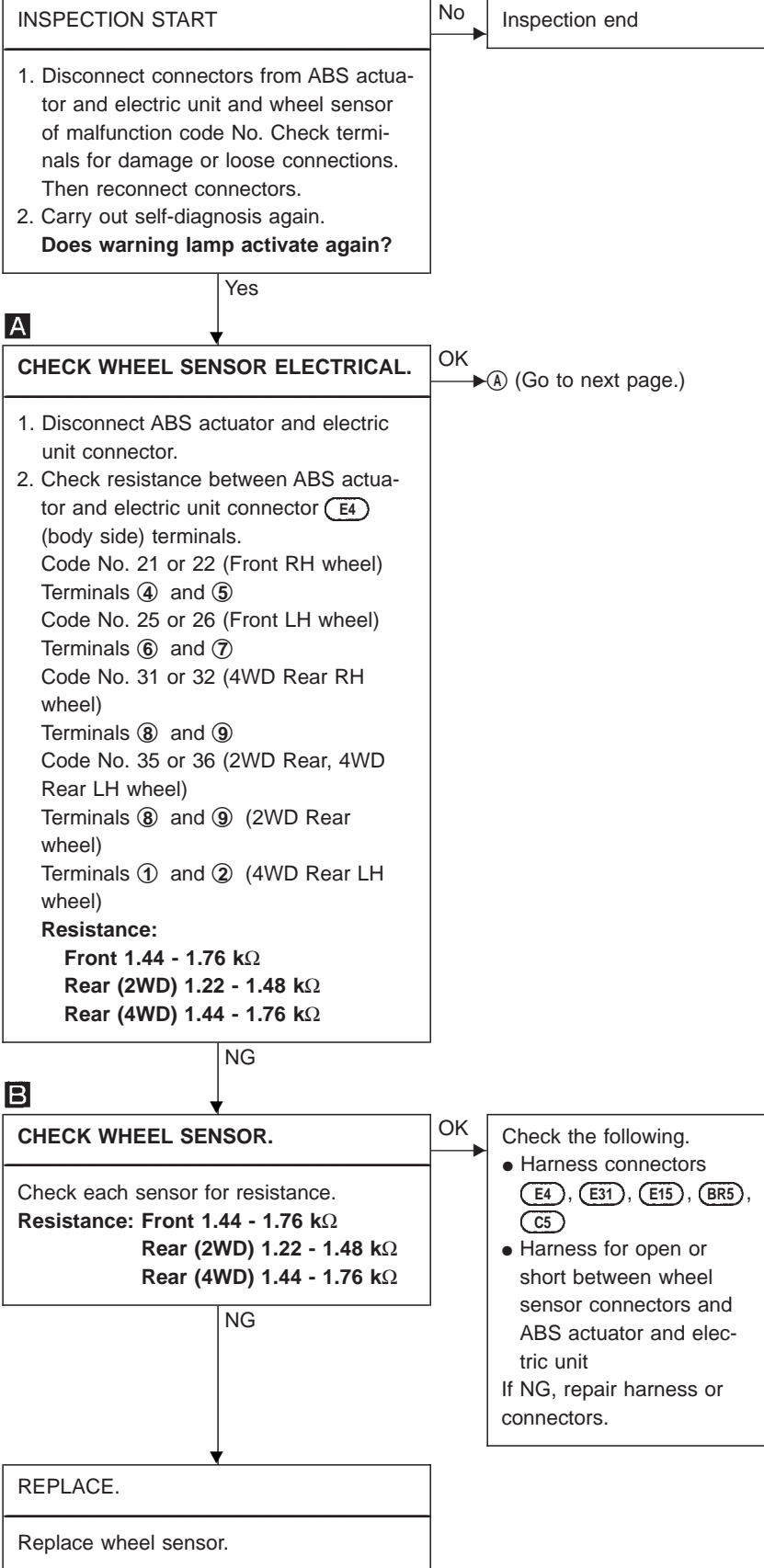
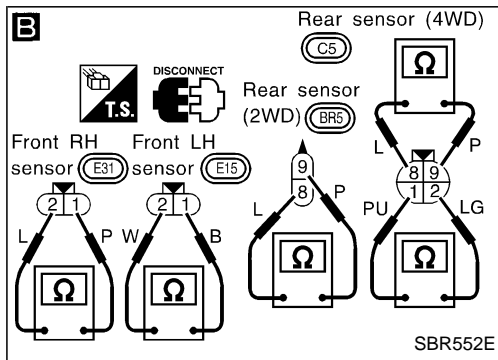
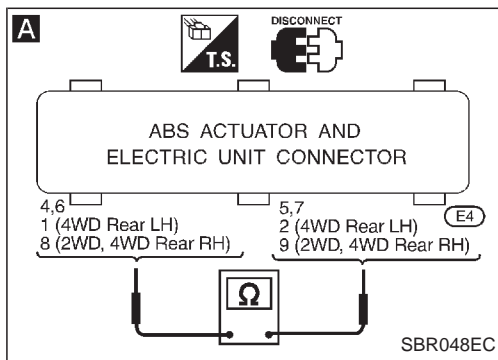
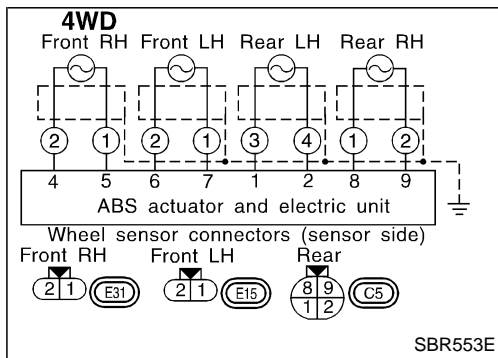
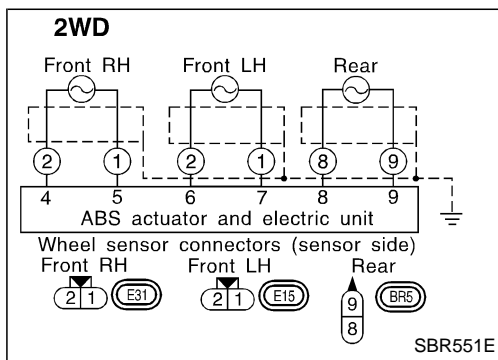

GI  
MA  
EM  
LC  
EC  
FE  
CL  
MT  
AT  
TF  
PD  
FA  
RA  
BR  
ST  
RS  
BT  
HA  
EL  
IDX

# TROUBLE DIAGNOSES FOR SELF-DIAGNOSTIC ITEMS

## Diagnostic Procedure 1 (Wheel sensor or rotor) (Cont'd)

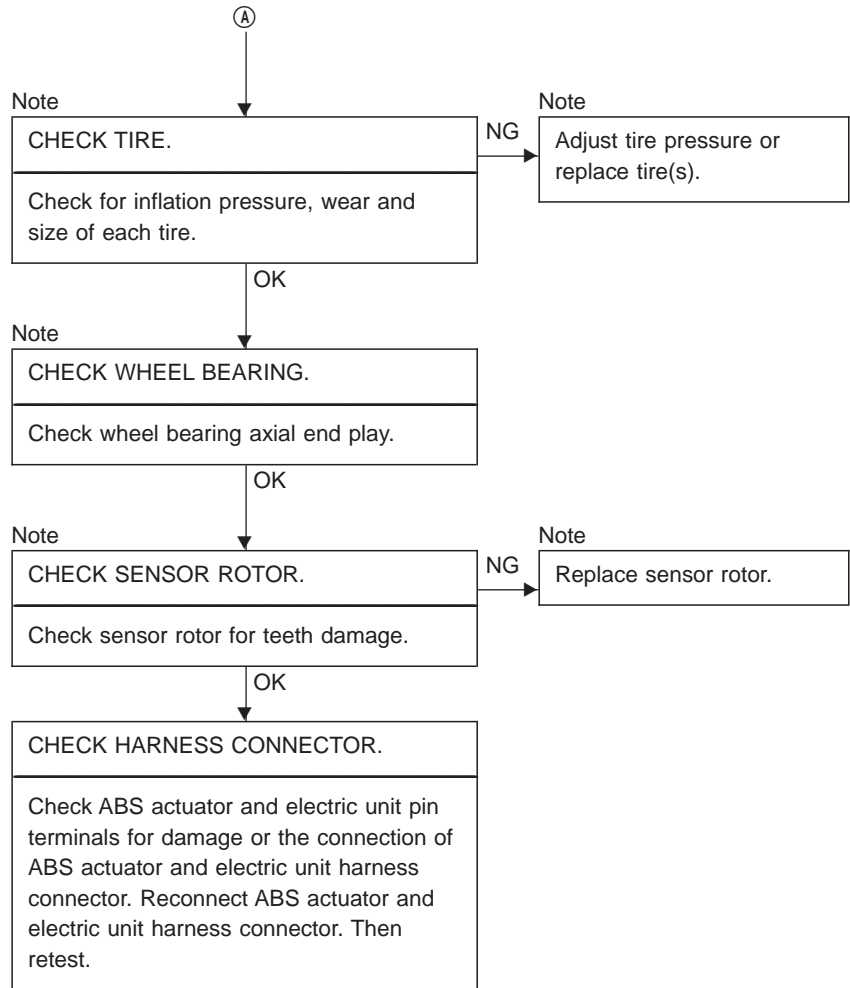

**Note: Wheel position should be distinguished by code numbers except code No. 18 (sensor rotor).**

# TROUBLE DIAGNOSES FOR SELF-DIAGNOSTIC ITEMS

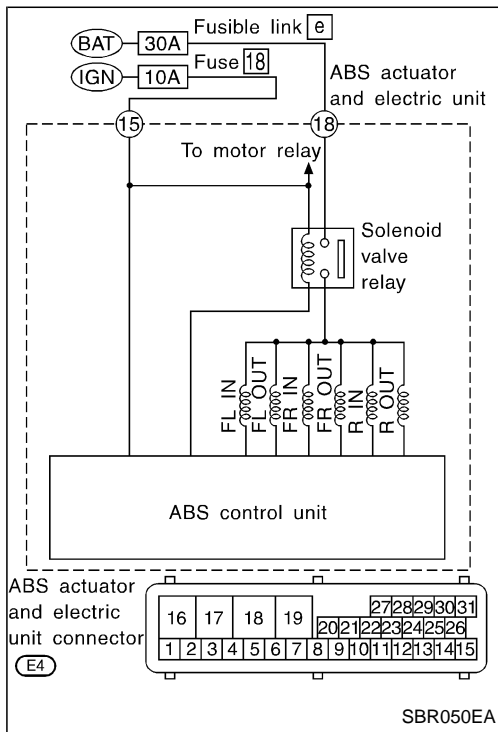

## Diagnostic Procedure 2 (ABS actuator solenoid valve and solenoid valve relay)

Malfunction code No. 41, 45, 55, 42, 46, 56, 63

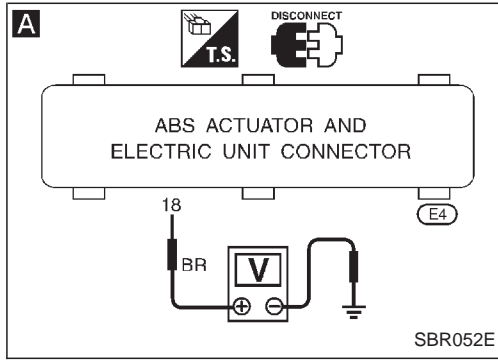
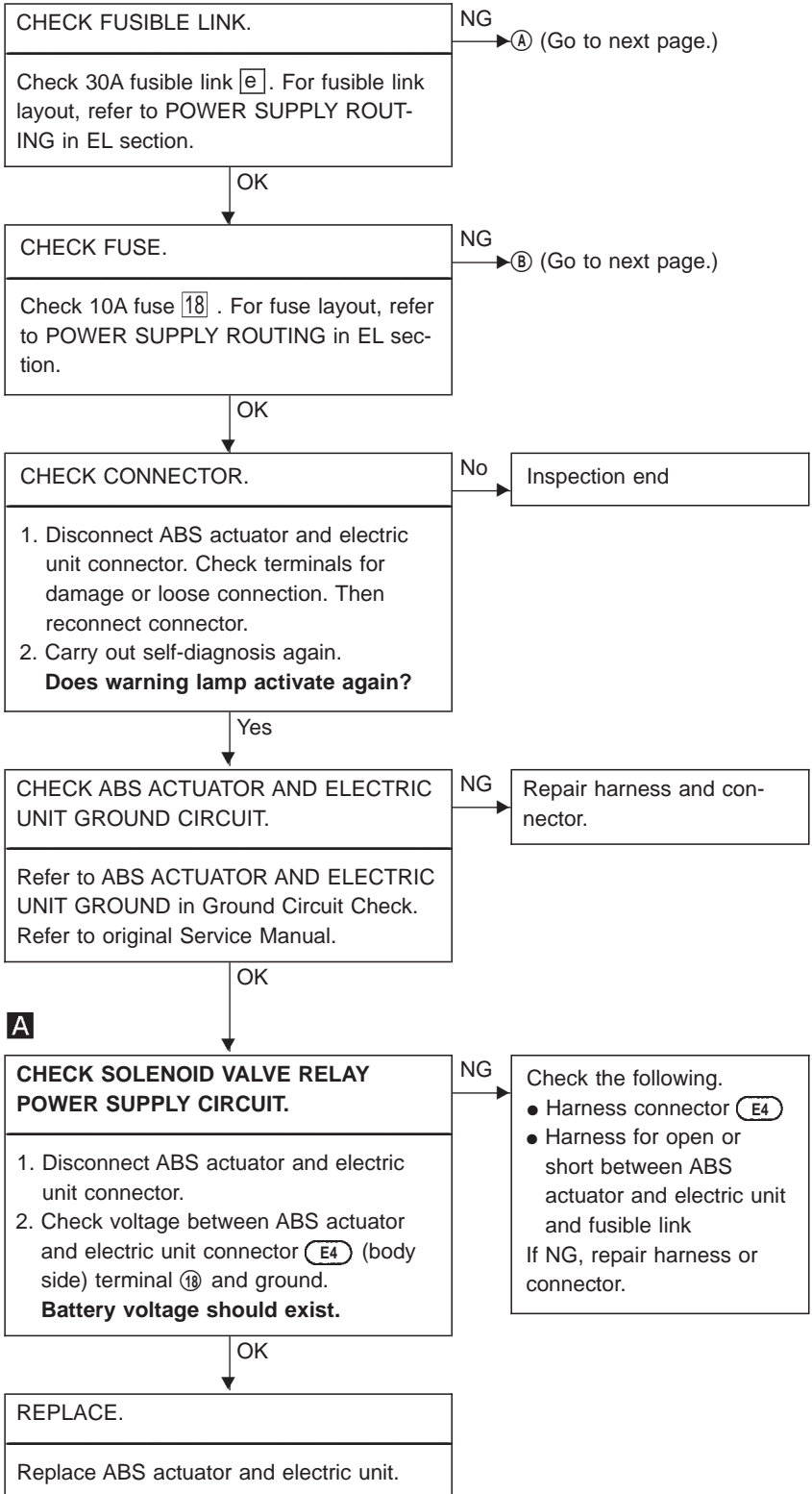

GI  
MA  
EM  
LC  
EC  
FE  
CL  
MT  
AT  
TF  
PD  
FA  
RA  
BR  
ST  
RS  
BT  
HA  
EL  
IDX

# TROUBLE DIAGNOSES FOR SELF-DIAGNOSTIC ITEMS

## Diagnostic Procedure 2 (ABS actuator solenoid valve and solenoid valve relay) (Cont'd)

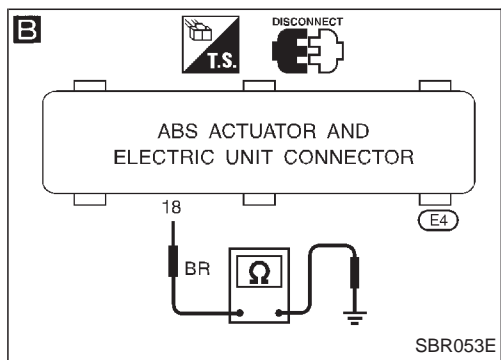

Ⓐ

REPLACE.

Replace fusible link.  
**Does the fusible link blow out when ignition switch is turned "ON"?**

No → Inspection end

Yes

Ⓑ

**CHECK SOLENOID VALVE RELAY POWER SUPPLY CIRCUIT.**

1. Disconnect ABS actuator and electric unit connector.  
 2. Check continuity between ABS actuator and electric unit connector (E4) (body side) terminal ⑱ and ground.  
**Continuity should not exit.**

NG → Check the following.  
 ● Harness connector (E4)  
 ● Harness for open or short between ABS actuator and electric unit and fusible link  
 If NG, repair harness or connector.

OK

REPLACE.

Replace ABS actuator and electric unit.

Ⓑ

REPLACE.

Replace fuse.  
**Does the fuse blow out when ignition switch is turned "ON"?**

Yes → Check the following.  
 ● Harness connector (E4)  
 ● Harness for open or short between ABS actuator and electric unit and fuse  
 If NG, repair harness or connector.

No

END

INSPECTION END

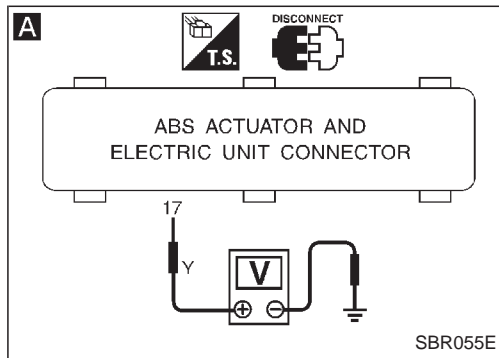
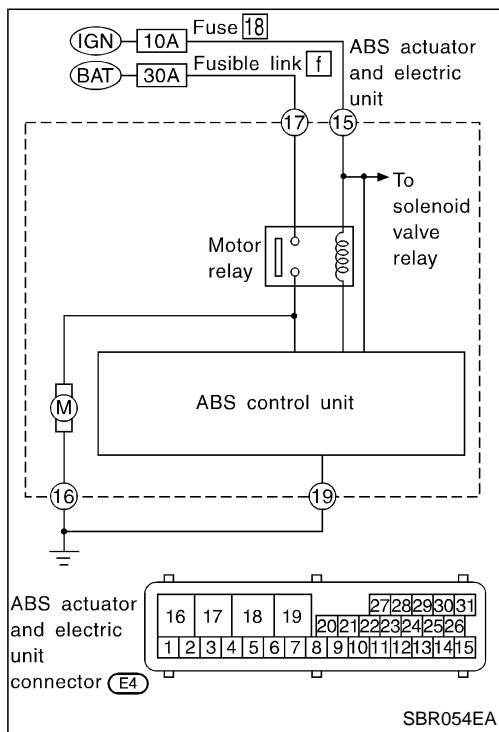

## Diagnostic Procedure 3 (Motor relay or motor)

### Malfunction code No. 61

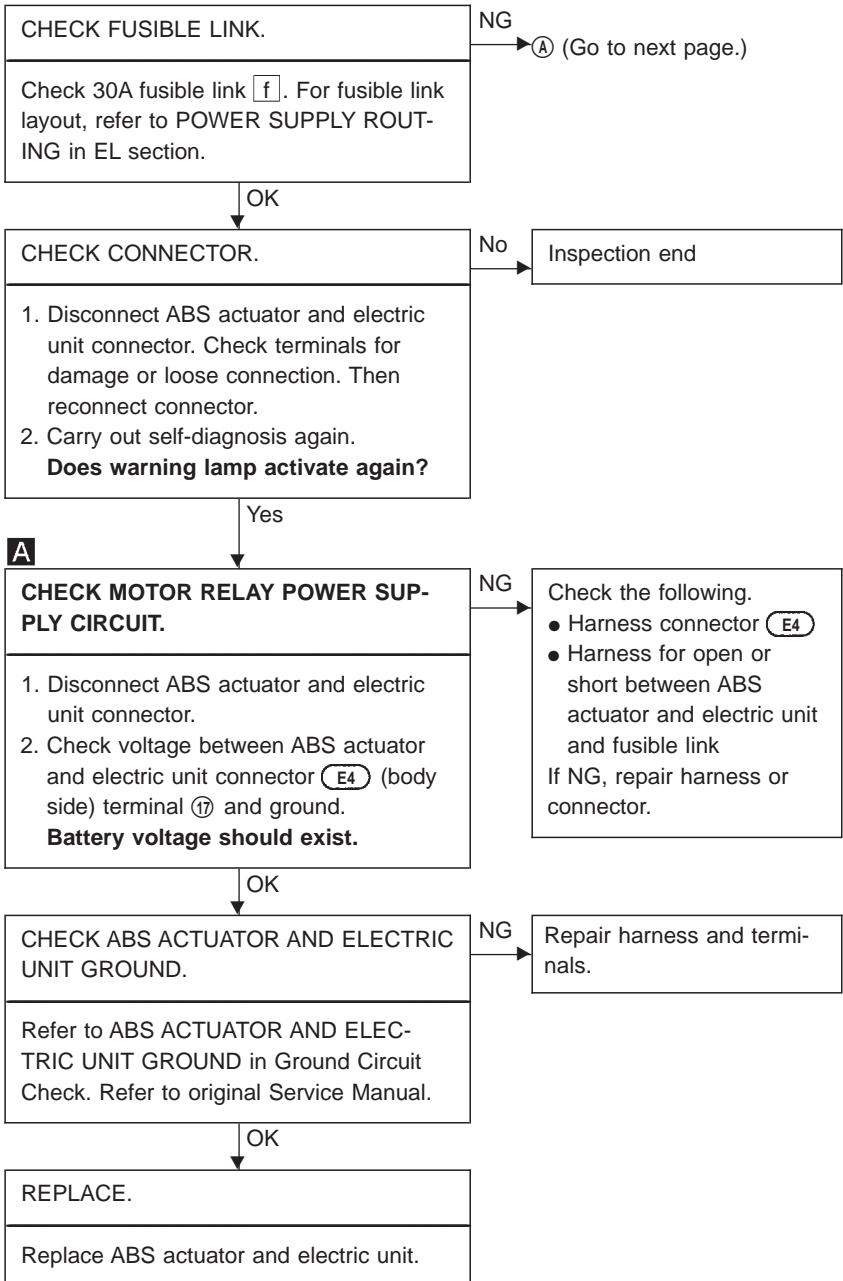

GI  
MA  
EM  
LC  
EC  
FE  
CL  
MT  
AT  
TF  
PD  
FA  
RA  
BR  
ST  
RS  
BT  
HA  
EL  
IDX

# TROUBLE DIAGNOSES FOR SELF-DIAGNOSTIC ITEMS

## Diagnostic Procedure 3 (Motor relay or motor) (Cont'd)

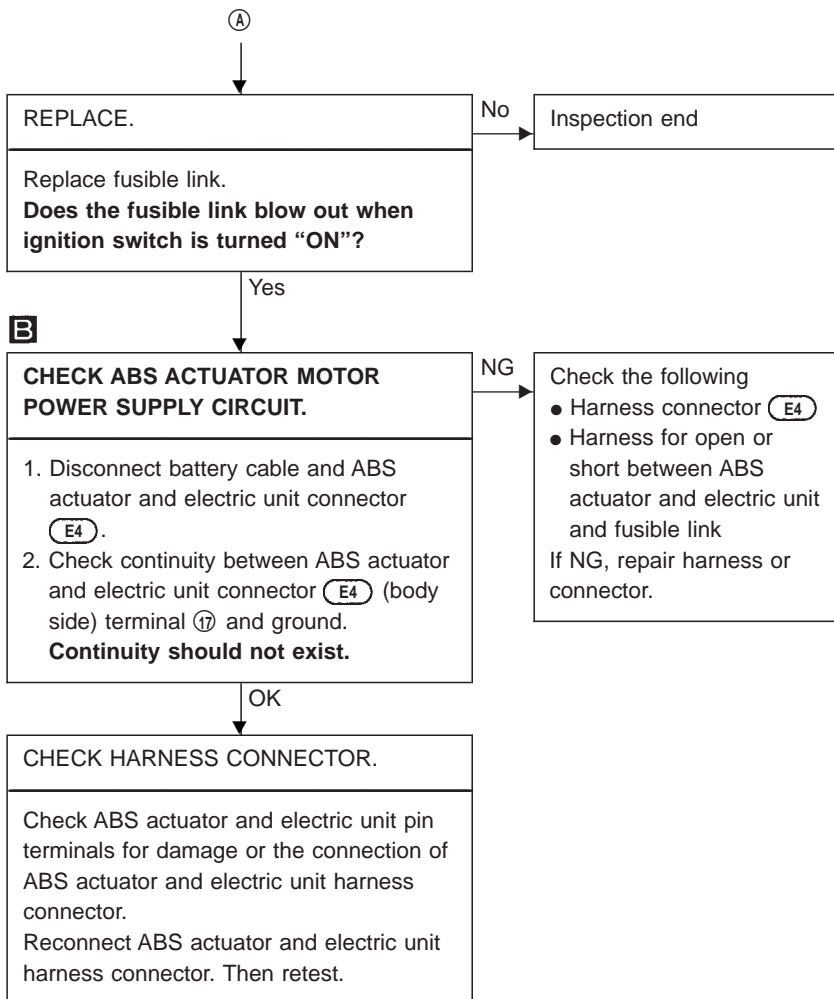
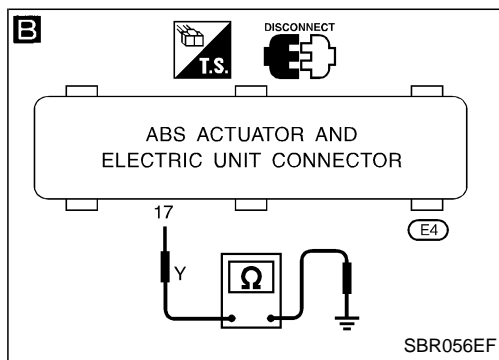



# TROUBLE DIAGNOSES FOR SELF-DIAGNOSTIC ITEMS

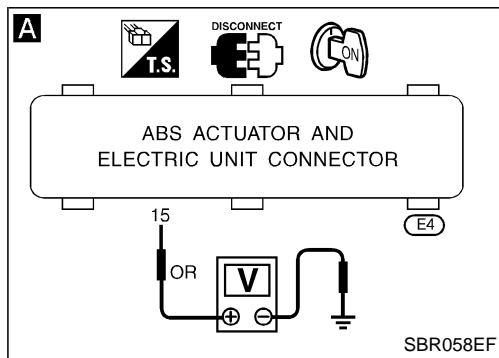
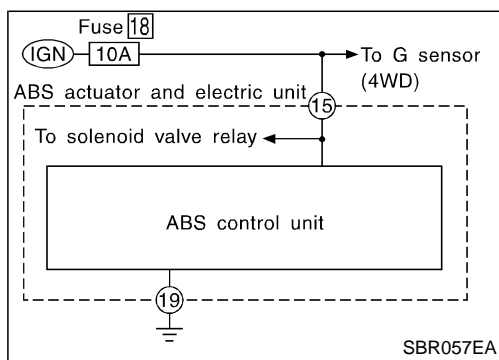

## Diagnostic Procedure 4 (Low voltage)

### Malfunction code No. 57

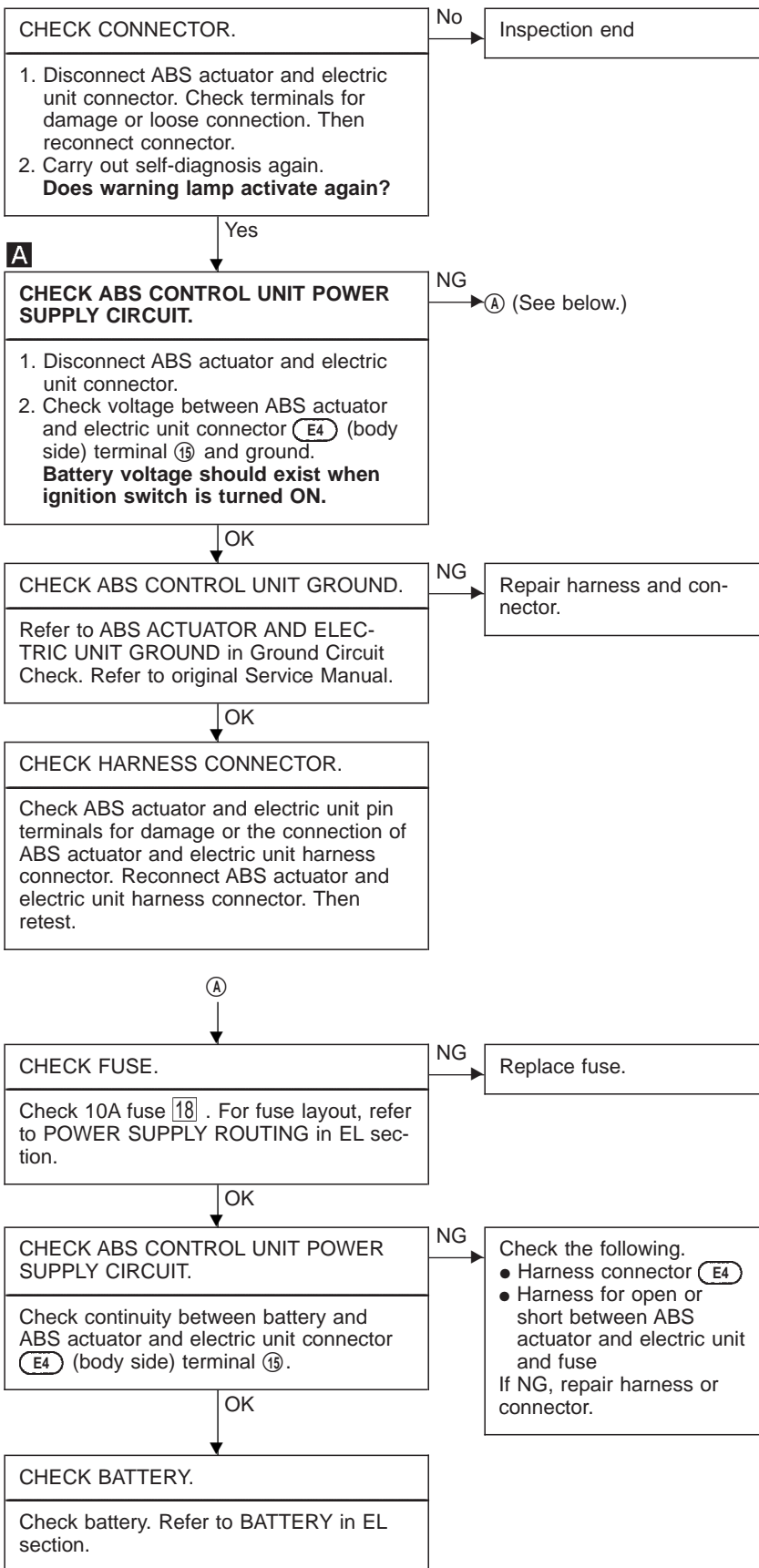

GI

MA

EM

LC

EC

FE

CL

MT

AT

TF

PD

FA

RA

BR

ST

RS

BT

HA

EL

IDX

# TROUBLE DIAGNOSES FOR SELF-DIAGNOSTIC ITEMS

## Diagnostic Procedure 5 (G sensor)

### Malfunction code No. 17

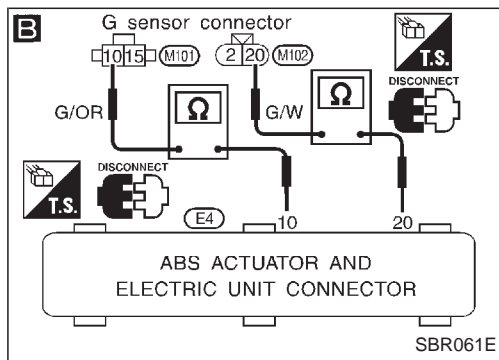
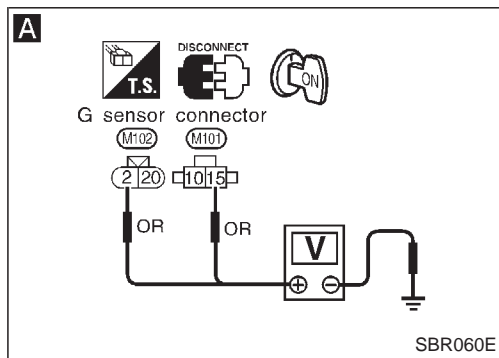
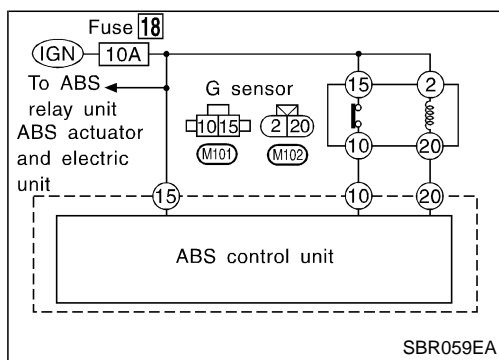

CHECK G SENSOR POWER SUPPLY CIRCUIT.

NG

Replace fuse.

Check 10A fuse 18. For fuse layout, refer to POWER SUPPLY ROUTING in EL section.

OK

CHECK CONNECTOR.

No

Inspection end

1. Disconnect ABS actuator and electric unit connector. Check terminals for damage or loose connection. Then reconnect connector.
2. Carry out self-diagnosis again.  
**Does warning lamp activate again?**

Yes

CHECK G SENSOR.

NG

Replace G sensor.

Refer to G SENSOR in Electrical Components Inspection, BR-27.

OK

**A**  
CHECK G SENSOR POWER SUPPLY CIRCUIT.

NG

1. Disconnect G sensor connector.
2. Check voltage between G sensor connector M101, M102 (body side) terminal 2, 15 and ground.  
**Battery voltage should exist.**

Check the following.

- Harness connectors M101, M102, E4
- Harness for open or short between G sensor and ABS actuator and electric unit

If NG, repair harness or connectors.

OK

**B**  
CHECK G SENSOR GROUND.

NG

1. Disconnect ABS actuator and electric unit connector and G sensor connectors.
2. Check continuity between ABS actuator and electric unit connector E4 (body side) terminals 10, 20 and G sensor connectors M101, M102 (body side) terminals 10, 20.  
**Continuity should exist.**

Check the following.

- Harness connectors M101, M102, E4
- Harness for open or short between G sensor and ABS actuator and electric unit

If NG, repair harness or connectors.

OK

CHECK HARNESS CONNECTOR.

Check ABS actuator and electric unit pin terminals for damage or the connection of ABS actuator and electric unit harness connector. Reconnect ABS actuator and electric unit harness connector. Then retest.

# TROUBLE DIAGNOSES FOR SELF-DIAGNOSTIC ITEMS

## Diagnostic Procedure 5 (G sensor) (Cont'd)

### ELECTRICAL COMPONENTS INSPECTION

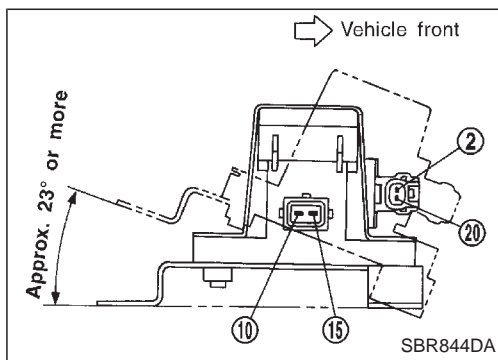

#### G sensor

#### CAUTION:

The G sensor is easily damaged if it sustains an impact. Be careful not to drop or bump it.

1. Measure resistance between terminals ⑩ and ⑮ of G sensor unit connector.

G sensor condition	Resistance between terminals ⑩ and ⑮	G sensor switch condition
Installed in vehicle	1.4 - 1.6 kΩ	"ON"
Tilted as shown in figure	4.7 - 5.5 kΩ	"OFF"

2. Measure resistance between terminals ② and ⑳ of the G sensor unit connector.

Resistance:	70 - 124 Ω
-------------	------------

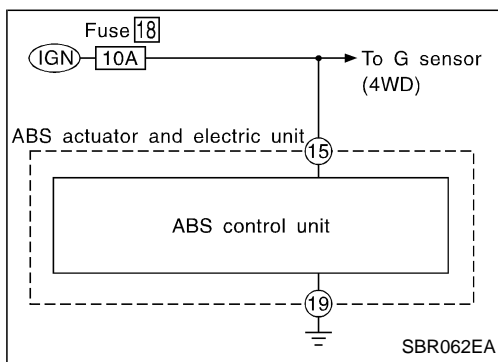

## Diagnostic Procedure 6 (Control unit)

### Malfunction code No. 71

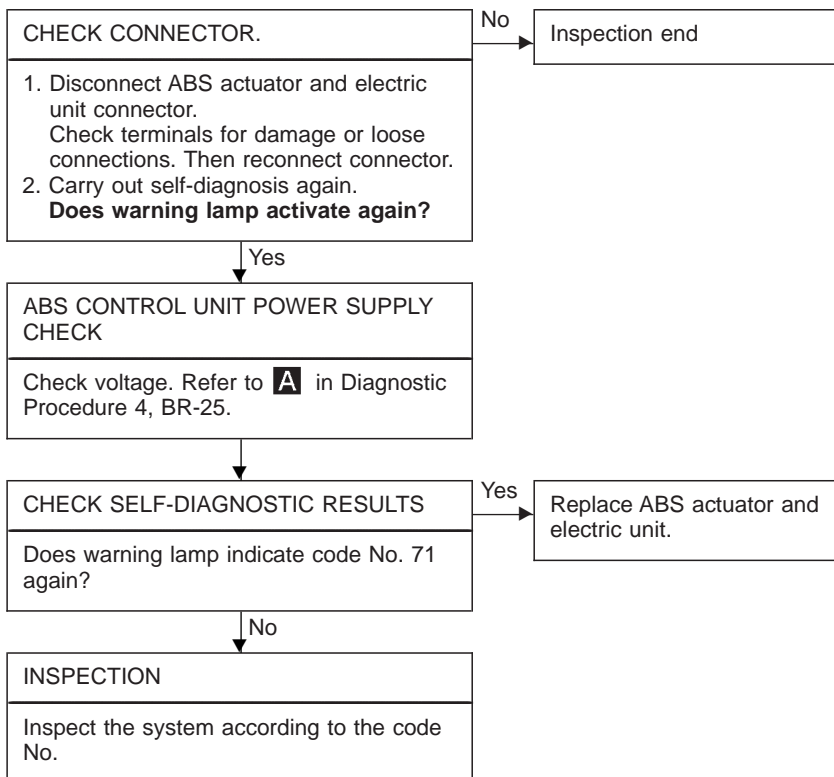

GI  
MA  
EM  
LC  
EC  
FE  
CL  
MT  
AT  
TF  
PD  
FA  
RA  
BR  
ST  
RS  
BT  
HA  
EL  
IDX

# TROUBLE DIAGNOSES FOR SYMPTOMS

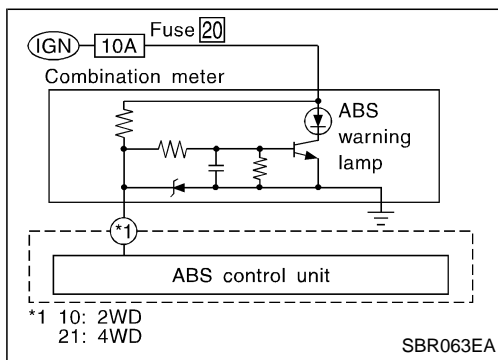

## Diagnostic Procedure 12 (Warning lamp does not come on when ignition switch is turned ON.)

**CHECK FUSE.**

Check 10A fuse 20 . For fuse layout, refer to POWER SUPPLY ROUTING in EL section.

NG → Replace fuse.

OK

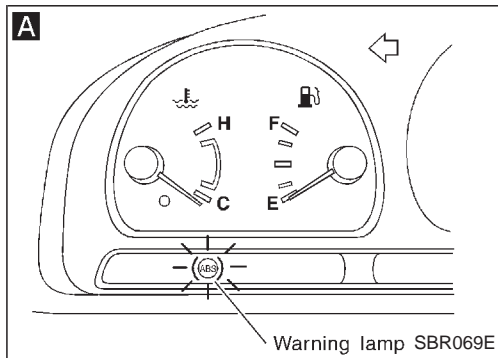

**A CHECK WARNING LAMP ACTIVATE.**

Disconnect ABS actuator and electric unit connector.  
Does the warning lamp activate?

Yes → (A) (Go to next page.)

No

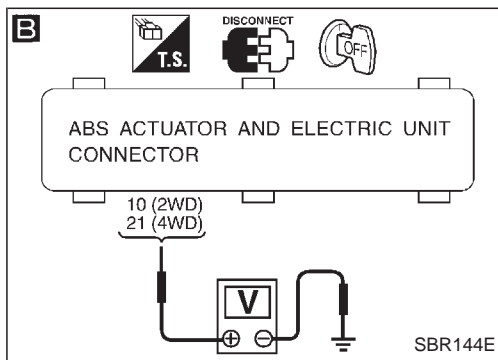

**B CHECK HARNESS FOR SHORT.**

1. Disconnect ABS actuator and electric unit connector.
2. Check voltage between ABS actuator and electric unit connector (E4) (body side) terminal 10 (2WD) or 21 (4WD) and ground.  
**Battery voltage should not exist.**

NG → Repair harness or connector.

OK

**CHECK COMBINATION METER.**

Check combination meter. Refer to WARNING LAMPS in EL section.

## TROUBLE DIAGNOSES FOR SYMPTOMS

### Diagnostic Procedure 12 (Warning lamp does not come on when ignition switch is turned ON.) (Cont'd)

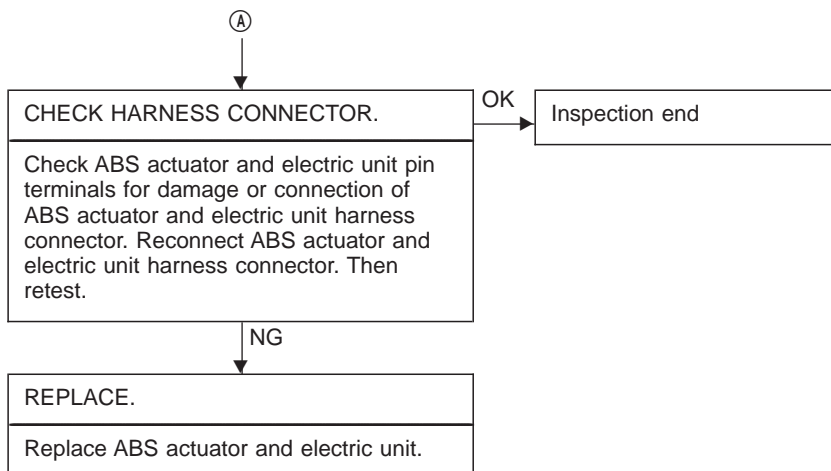

GI

MA

EM

LC

EC

FE

CL

MT

AT

TF

PD

FA

RA

**BR**

ST

RS

BT

HA

EL

IDX

# TROUBLE DIAGNOSES FOR SYMPTOMS

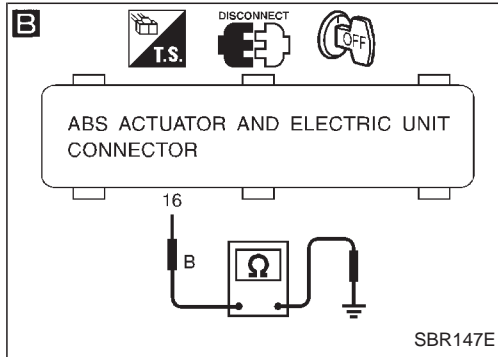
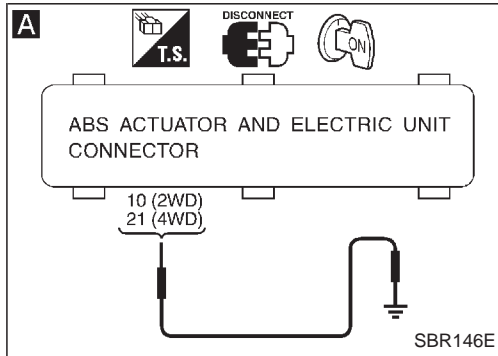
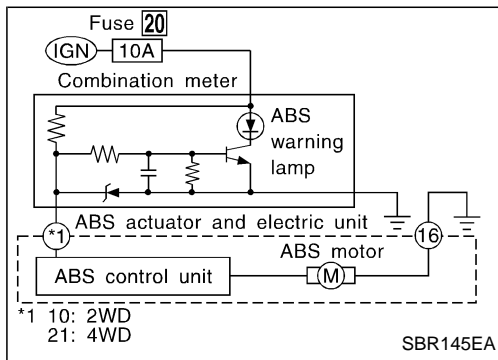

## Diagnostic Procedure 13 (Warning lamp stays on when ignition switch is turned ON.)

**A**

### CHECK WARNING LAMP.

1. Disconnect ABS actuator and electric unit connector.
  2. Connect suitable wire between ABS actuator and electric unit connector (E4) (body side) terminal ⑩ (2WD) or ⑳ (4WD) and ground.
- Warning lamp should not activate.**

NG

Repair combination meter. Check the following.

- Harness connector (E4)
- Harness for open or short between ABS actuator and electric unit and fuse

If NG, repair harness or connector.

OK

### CHECK HARNESS CONNECTOR.

Check ABS actuator and electric unit pin terminals for damage or the connection of ABS actuator and electric unit harness connector. Reconnect ABS actuator and electric unit harness connector. Then retest.

OK

Inspection end

NG

**B**

### CHECK ABS MOTOR GROUND.

1. Turn ignition switch "OFF".
  2. Disconnect ABS actuator and electric unit connector.
  3. Check continuity between ABS actuator and electric unit connector (E4) (body side) ⑯ and ground.
- Continuity should exist.**

NG

Check the following.

- Harness connector (E4)
- Harness for open or short between ABS actuator and electric unit and ground

If NG, repair harness or connector.

OK

REPLACE.

Replace ABS actuator and electric unit.

# SERVICE DATA AND SPECIFICATIONS (SDS)

## General Specifications

### 2WD MODELS

Destination	Australia		Except Australia and Middle East		Middle East		Europe	
Applied model	KA24DE	TD27	Without ABS	With ABS	Except for KA24DE engine model with ABS	KA24DE engine model with ABS	With ABS	Without ABS
Front brake								
Type	CL28VD disc brake	CL28VA disc brake		CL28VD disc brake				
Cylinder bore diameter mm (in)	42.8 (1.685) x 2	60.6 (2.386)		42.8 (1.685) x 2				
Pad dimension mm (in) Length x width x thickness	146.6 x 48.5 x 10.0 (5.77 x 1.909 x 0.394)	IN: 126.5 x 43 x 11 (4.98 x 1.69 x 0.43) OUT: 129.0 x 43 x 11 (5.08 x 1.69 x 0.43)		146.6 x 48.5 x 10.0 (5.77 x 1.909 x 0.394)				
Rotor outer diameter x thickness mm (in)	260 x 26 (10.24 x 1.02)	250 x 22 (9.84 x 0.87)		260 x 26 (10.24 x 1.02)				
Rear brake								
Type	LT26B drum brake							
Wheel cylinder bore diameter mm (in)	23.81 (15/16)							
Lining dimension mm (in) Length x width x thickness	249.6 x 50 x 5.5 (9.83 x 1.97 x 0.217)							
Drum inner diameter mm (in)	260 (10.24)							
Master cylinder bore diameter mm (in)	23.81 (15/16)		25.4 (1)		23.81 (15/16)		25.4 (1)	
Control valve								
Type	LSV							
Split point x reducing ratio kPa (bar, kg/cm <sup>2</sup> , psi)	(Variable) x 0.15							
Brake booster								
Model	M195T		S230		M195T		M215T	
Diaphragm diameter mm (in)	Primary: 205 (8.07) Secondary: 180 (7.09)		230 (9.06)		Primary: 205 (8.07) Secondary: 180 (7.09)		Primary: 230 (9.06) Secondary: 205 (8.07)	
Recommended brake fluid	DOT 3						DOT 4*	

\* Never mix DOT 3 and DOT 4 (DOT 3 is filled at factory).

GI  
MA  
EM  
LC  
EC  
FE  
CL  
MT  
AT  
TF  
PD  
FA  
RA  
BR  
ST  
RS  
BT  
HA  
EL  
IDX

# SERVICE DATA AND SPECIFICATIONS (SDS)

## General Specifications (Cont'd)

### 4WD MODELS

Destination	Australia		Except Australia and Middle East				Middle East		Europe
Applied model	Except QD32	QD32	QD32		Except QD32		Without ABS	With ABS	All
			With ABS	Without ABS	With ABS	Without ABS			
Front brake									
Type	CL28VD disc brake				CL28VA disc brake		CL28VD disc brake		
Cylinder bore diameter mm (in)	42.8 (1.685) x 2				60.6 (2.386)		42.8 (1.685) x 2		
Pad dimension mm (in) Length x width x thickness	146.6 x 48.5 x 10 (5.77 x 1.909 x 0.39)				IN: 126.5 x 43 x 11 (4.98 x 1.69 x 0.43) OUT: 129.0 x 43 x 11 (5.08 x 1.69 x 0.43)		146.6 x 48.5 x 10 (5.77 x 1.909 x 0.39)		
Rotor outer diameter x thickness mm (in)	277 x 26 (10.91 x 1.02)				267 x 22 (10.51 x 0.87)		277 x 26 (10.91 x 1.02)		
Rear brake									
Type	LT30A drum brake								
Wheel cylinder bore diameter mm (in)	22.22 (7/8)								
Lining dimension mm (in) Length x width x thickness	296.0 x 50.0 x 6.1 (11.65 x 1.969 x 0.240)								
Drum inner diameter mm (in)	295 (11.61)								
Master cylinder bore diameter mm (in)	23.81 (15/16)								
Control valve									
Type	LSV								
Split point x reducing ratio kPa (bar, kg/cm <sup>2</sup> , psi)	(Variable) x 0.15								
Brake booster									
Model	M215T	M195T	M215T	M195T	M215T	M195T	M215T		
Diaphragm diameter mm (in)	Primary: 230 (9.06) Secondary: 205 (8.07)	Primary: 250 (9.84) Secondary: 180 (7.09)	Primary: 230 (9.06) Secondary: 205 (8.07)	Primary: 205 (8.07) Secondary: 180 (7.09)	Primary: 230 (9.06) Secondary: 205 (8.07)	Primary: 205 (8.07) Secondary: 180 (7.09)	Primary: 230 (9.06) Secondary: 205 (8.07)		
Recommended brake fluid	DOT 3								DOT 4*

\* Never mix DOT 3 and DOT 4 (DOT 3 is filled at factory).