

SECTION BT

CONTENTS

PRECAUTIONS	2	Roof Trim	21
Service Notice.....	2	EXTERIOR	23
Supplemental Restraint System (SRS) "AIR BAG" (4WD models)	2	SEAT	28
Supplemental Restraint System (SRS) "AIR BAG" (2WD models)	2	Front Seat.....	28
GENERAL SERVICING	3	Heated Seat.....	30
Clip and Fastener	3	Rear Seat.....	31
BODY END	5	SUNROOF	32
Body Front End.....	5	WINDSHIELD AND WINDOWS	33
Body Rear End	8	Windshield	34
DOOR	10	MIRROR	35
Front Door.....	10	Door Mirror.....	35
Rear Door	11	CAB AND REAR BODY	36
INSTRUMENT PANEL	12	Removal.....	36
INTERIOR TRIM	15	Body Mounting.....	37
Side and Floor Trim	15	BODY ALIGNMENT	38
Door Trim	18	Engine Compartment.....	39
		Underbody	41

- ★ For seat belt, refer to MA and RS section.
- ★ For wiring diagrams of body electrical systems, refer to EL section.

GI
MA
EM
LC
EC
FE
CL
MT
TF
PD
FA
RA
BR
ST
RS
BT
HA
EL
IDX

PRECAUTIONS

Service Notice

- When removing or installing various parts, place a cloth or padding onto the vehicle body to prevent scratches.
- Handle trim, molding, instruments, grille, etc. carefully during removing or installing. Be careful not to soil or damage them.
- Apply sealing compound where necessary when installing parts.
- When applying sealing compound, be careful that the sealing compound does not protrude from parts.
- When replacing any metal parts (for example body outer panel, members, etc.), be sure to take rust prevention measures.

Supplemental Restraint System (SRS) “AIR BAG” (4WD models)

The Supplemental Restraint System “Air Bag”, used along with a seat belt, helps to reduce the risk or severity of injury to the driver in a frontal collision. The Supplemental Restraint System consists of air bag module (located in the center of the steering wheel), a diagnosis sensor unit, warning lamp, wiring harness and spiral cable. Information necessary to service the system safely is included in the **RS section** of this Service Manual.

WARNING:

- **To avoid rendering the SRS inoperative, which could increase the risk of personal injury or death in the event of a collision which would result in air bag inflation, all maintenance must be performed by an authorized NISSAN dealer.**
- **Improper maintenance, including incorrect removal and installation of the SRS, can lead to personal injury caused by unintentional activation of the system.**
- **Do not use electrical test equipment on any circuit related to the SRS unless instructed to in this Service Manual. SRS wiring harnesses are covered with yellow insulation either just before the harness connectors or for the complete harness, for easy identification.**

Supplemental Restraint System (SRS) “AIR BAG” (2WD models)

The Supplemental Restraint System “Air Bag”, used along with a seat belt, helps to reduce the risk or severity of injury to the driver in a frontal collision. The Supplemental Restraint System consists of air bag module (located in the center of the steering wheel), diagnosis sensor unit, warning lamp, wiring harness and spiral cable. Information necessary to service the system safely is included in the **RS section** of this Service Manual.







WARNING:

- **To avoid rendering the SRS inoperative, which could increase the risk of personal injury or death in the event of a collision which would result in air bag inflation, all maintenance must be performed by an authorized NISSAN dealer.**
- **Improper maintenance, including incorrect removal and installation of the SRS, can lead to personal injury caused by unintentional activation of the system.**
- **Do not use electrical test equipment on any circuit related to the SRS unless instructed to in this Service Manual.**

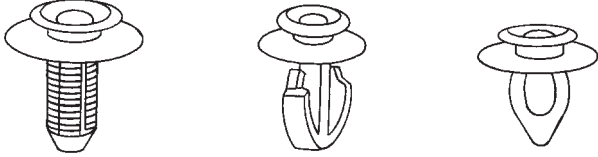
GENERAL SERVICING

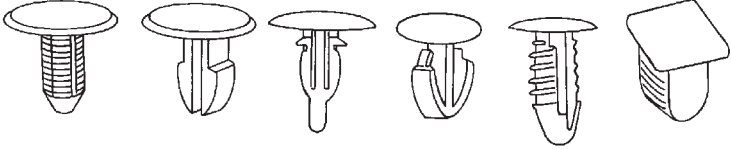
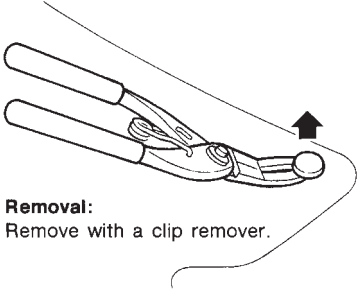
Clip and Fastener

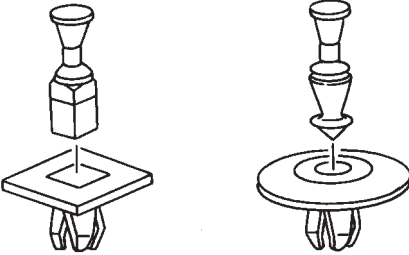
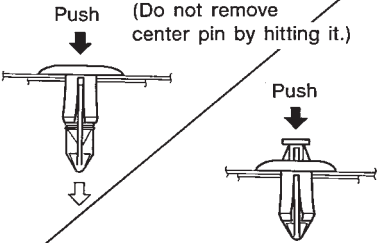
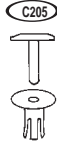
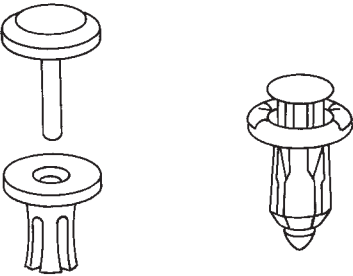
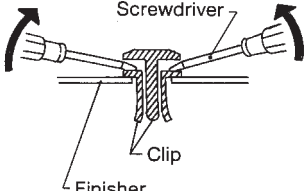

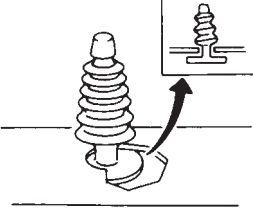
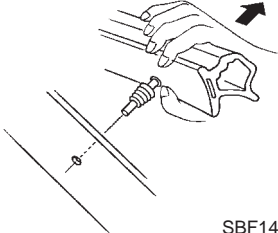







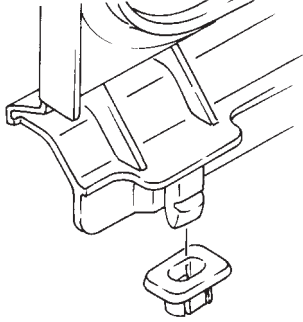
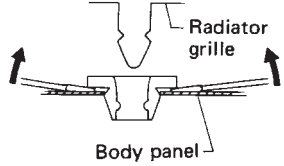

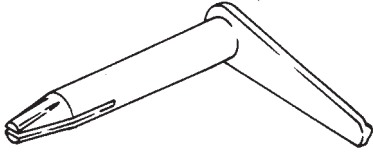

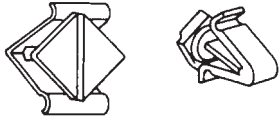
- Clips and fasteners in BT section correspond to the following numbers and symbols.
- Replace any clips and/or fasteners which are damaged during removal or installation.

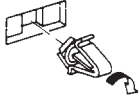
Symbol No.	Shapes	Removal & Installation
	 <p style="text-align: right;">SBF302H</p>	<p>Removal: Remove by bending up with flat-bladed screwdrivers or clip remover.</p>  <p style="text-align: right;">SBF367BA</p>
	 <p style="text-align: right;">SBT095</p>	 <p>Removal: Remove with a clip remover.</p> <p style="text-align: right;">SBF423H</p>
	 <p style="text-align: right;">SBF258G</p>	<p>Push center pin to catching position. (Do not remove center pin by hitting it.)</p>  <p>Installation:</p> <p style="text-align: right;">SBF708E</p>
	 <p style="text-align: right;">MBF518B</p>	<p>Removal:</p>  <p style="text-align: right;">SBF638C</p>
	 <p style="text-align: right;">SBF104B</p>	<p>Removal:</p>  <p style="text-align: right;">SBF147B</p>

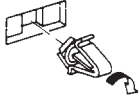
GI
MA
EM
LC
EC
FE
CL
MT
TF
PD
FA
RA
BR
ST
RS
BT
HA
EL
IDX

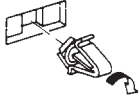
GENERAL SERVICING

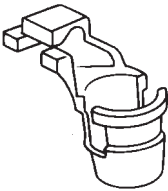
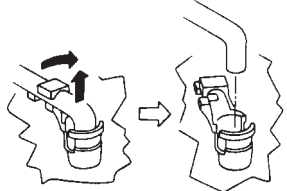
Clip and Fastener (Cont'd)

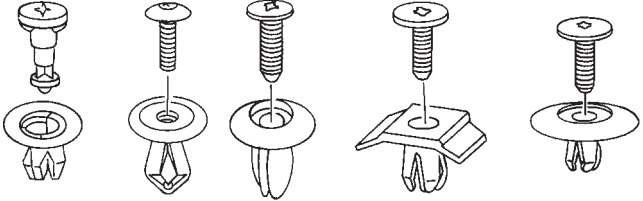
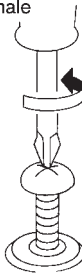
Symbol No.	Shapes	Removal & Installation				
	 <p style="text-align: right;">SBF351C</p>	<p>Removal: Remove by bending up with flat-bladed screwdrivers.</p>  <p style="text-align: right;">SBF352C</p>				
	 <p style="text-align: right;">SBF353C</p>	<p style="text-align: center;">—</p>				
	 <p style="text-align: right;">SBF145B</p>	<table border="0" style="width: 100%;"> <tr> <td style="width: 50%; vertical-align: top;"> <p>Removal:</p>  <p>Rotate 45° to remove.</p> </td> <td style="width: 50%; vertical-align: top;"> <p>Installation:</p>  </td> </tr> <tr> <td colspan="2" style="text-align: center;"> <p>Removal:</p>  </td> </tr> </table> <p style="text-align: right;">SBF085B</p>	<p>Removal:</p>  <p>Rotate 45° to remove.</p>	<p>Installation:</p> 	<p>Removal:</p> 	
<p>Removal:</p>  <p>Rotate 45° to remove.</p>	<p>Installation:</p> 					
<p>Removal:</p> 						
	 <p style="text-align: right;">SBF768B</p>	<p>Removal: Holder portion of clip must be spread out to remove rod.</p>  <p style="text-align: right;">SBF770B</p>				
	 <p style="text-align: right;">SBF078B</p>	<p>Removal:</p> <ol style="list-style-type: none"> Screw out with a Phillips screwdriver. Remove female portion with flat-bladed screwdriver.  <p style="text-align: right;">SBF992G</p>				

BODY END

Body Front End

- When removing or installing hood, place a cloth or other padding on hood. This prevents vehicle body from being scratched. GI
- Bumper fascia is made of plastic. Do not use excessive force and be sure to keep oil away from it.
- Hood adjustment: Adjust at hinge portion. MA
- Hood lock adjustment: After adjusting, check hood lock control operation. Apply a coat of grease to hood locks engaging mechanism. EM
- Hood opener: Do not attempt to bend cable forcibly. Doing so increases effort required to unlock hood. EM

REMOVAL — Front bumper assembly

- ① Remove screws securing left and right combination lamps and remove the lamps. **A** LC
- ② Remove clips securing front grille and remove the front grille. **B**
- ③ Remove bolts securing left and right bumper stays. **C** EC
- ④ Remove bolts securing left and right bumper side brackets. **D**
- ⑤ Remove bolts securing left and right bumper side stays. **E**
- ⑥ Extract bumper assembly. FE

CL

MT

TF

PD

FA

RA

BR

ST

RS

BT

HA

EL

IDX

BODY END

Body Front End (Cont'd)

Hood lock adjustment

- Adjust hood so that hood primary lock meshes at a position 1 to 1.5 mm (0.039 to 0.059 in) lower than fender.
- After hood lock adjustment, adjust bumper rubber.
- When securing hood lock, ensure it does not tilt. Striker must be positioned at the center of hood primary lock.
- After adjustment, ensure that hood primary and secondary lock operate properly.

Hood lock secondary latch hooking length

More than 5.0 mm (0.197 in)

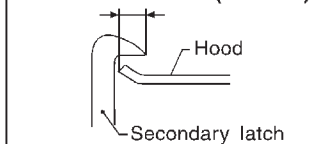

Bumper rubber adjustment

- Adjust so that hood is aligned with fender. At that time deflection is approx. 2 mm (0.08 in).

[Bumper rubber free height is approx. 13 mm (0.51 in).]

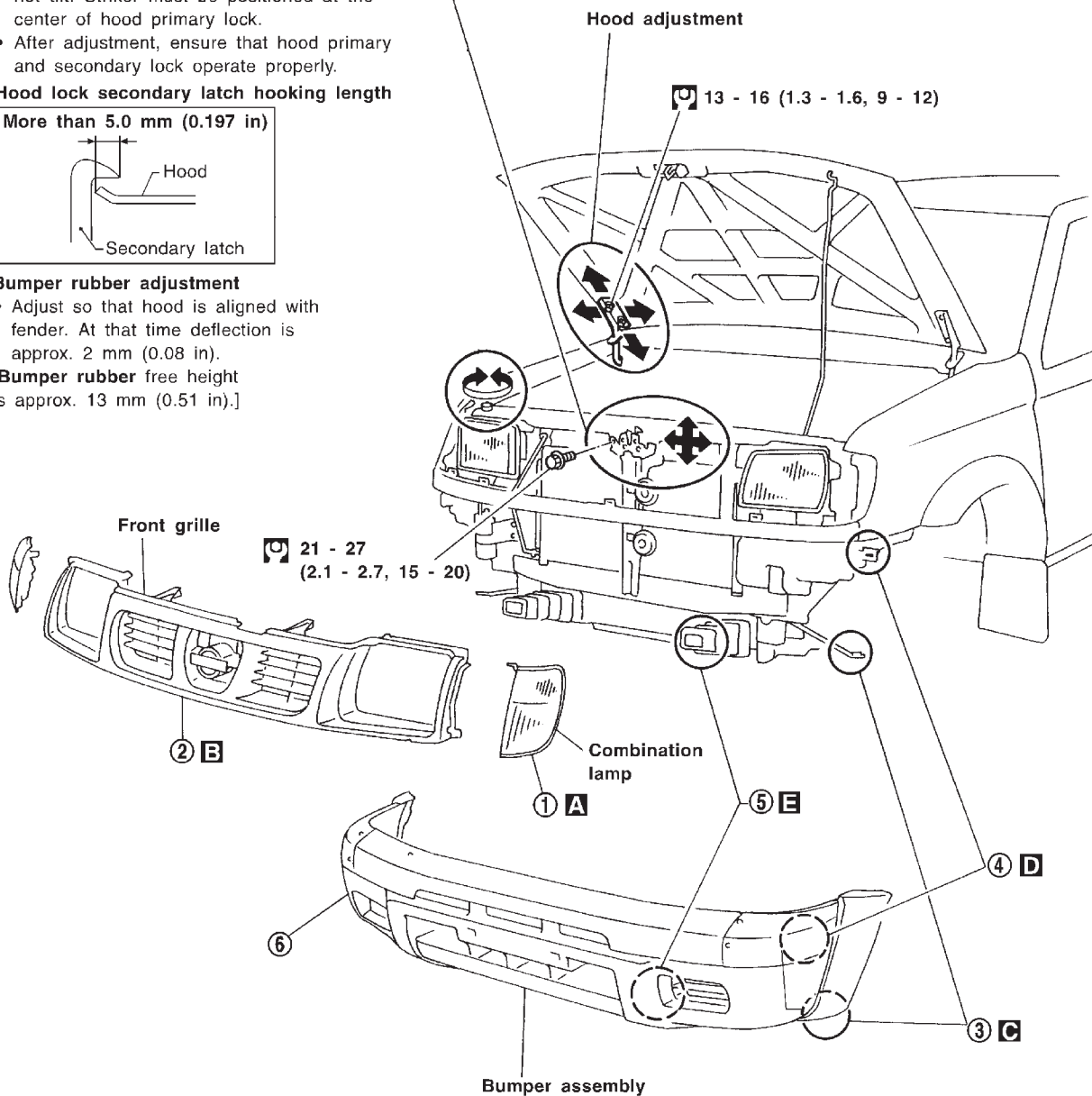

BODY END

Body Front End (Cont'd)

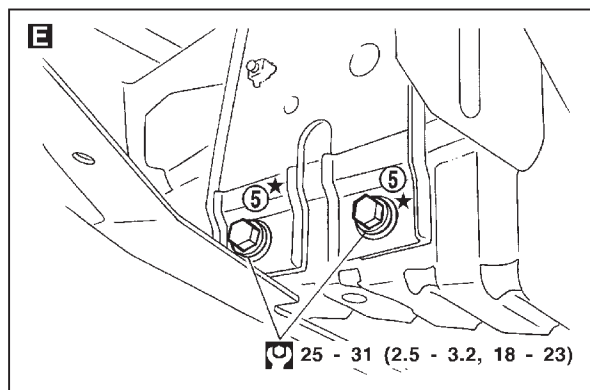
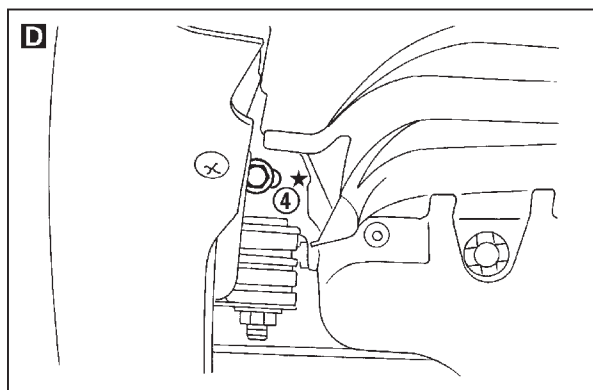
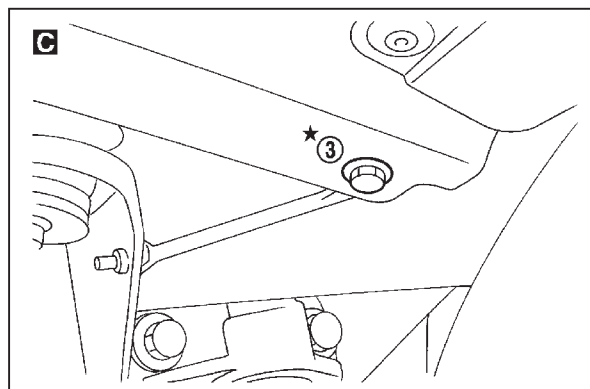
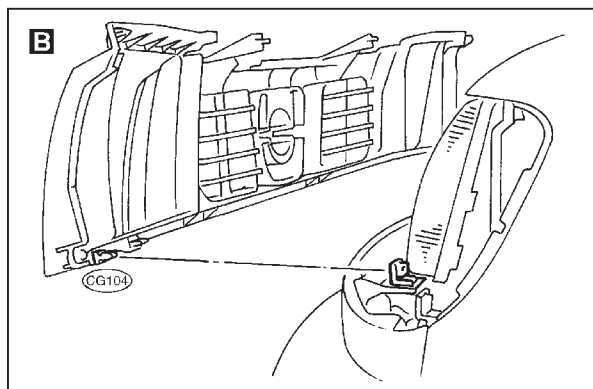
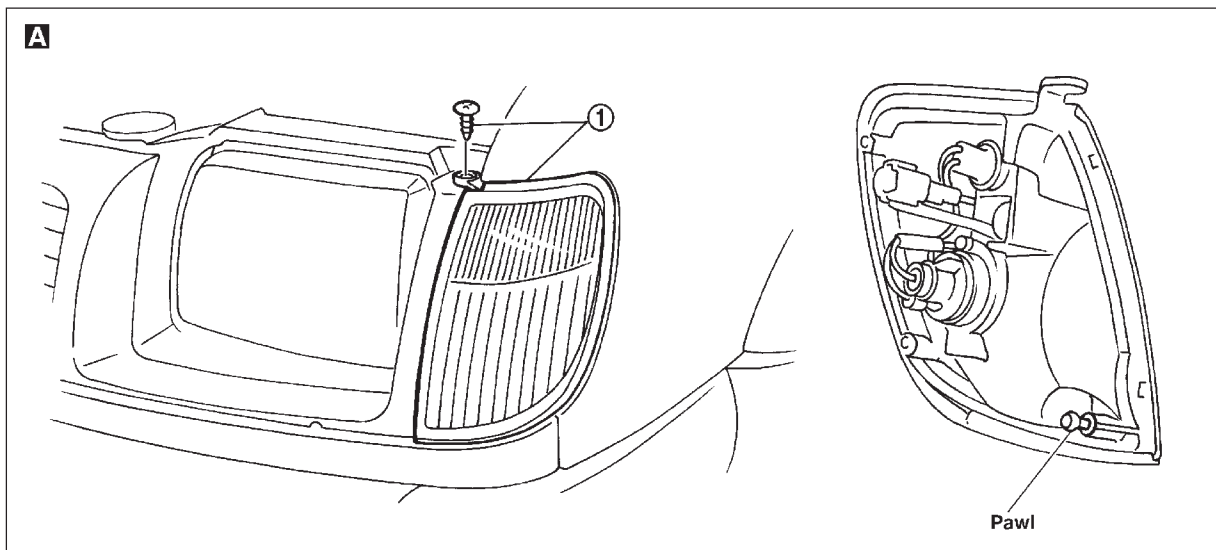

: N·m (kg-m, ft-lb)

★ : Bumper assembly mounting bolts

GI

MA

EM

LC

EC

FE

CL

MT

TF

PD

FA

RA

BR

ST

RS

BT

HA

EL

IDX

BODY END

Body Rear End

- Adjustment: Adjust at hinge portion for proper fit.
- Lock system adjustment: Adjust striker so that it is in the center of the lock. After adjustment, check trunk lid lock operation.
- After installation, make sure that rear gate opens smoothly.

REMOVAL — Rear bumper assembly

- ① Remove connectors securing license plate lamps.
- ② Remove nuts securing bumper side stay. **A**
- ③ Extract bumper assembly.

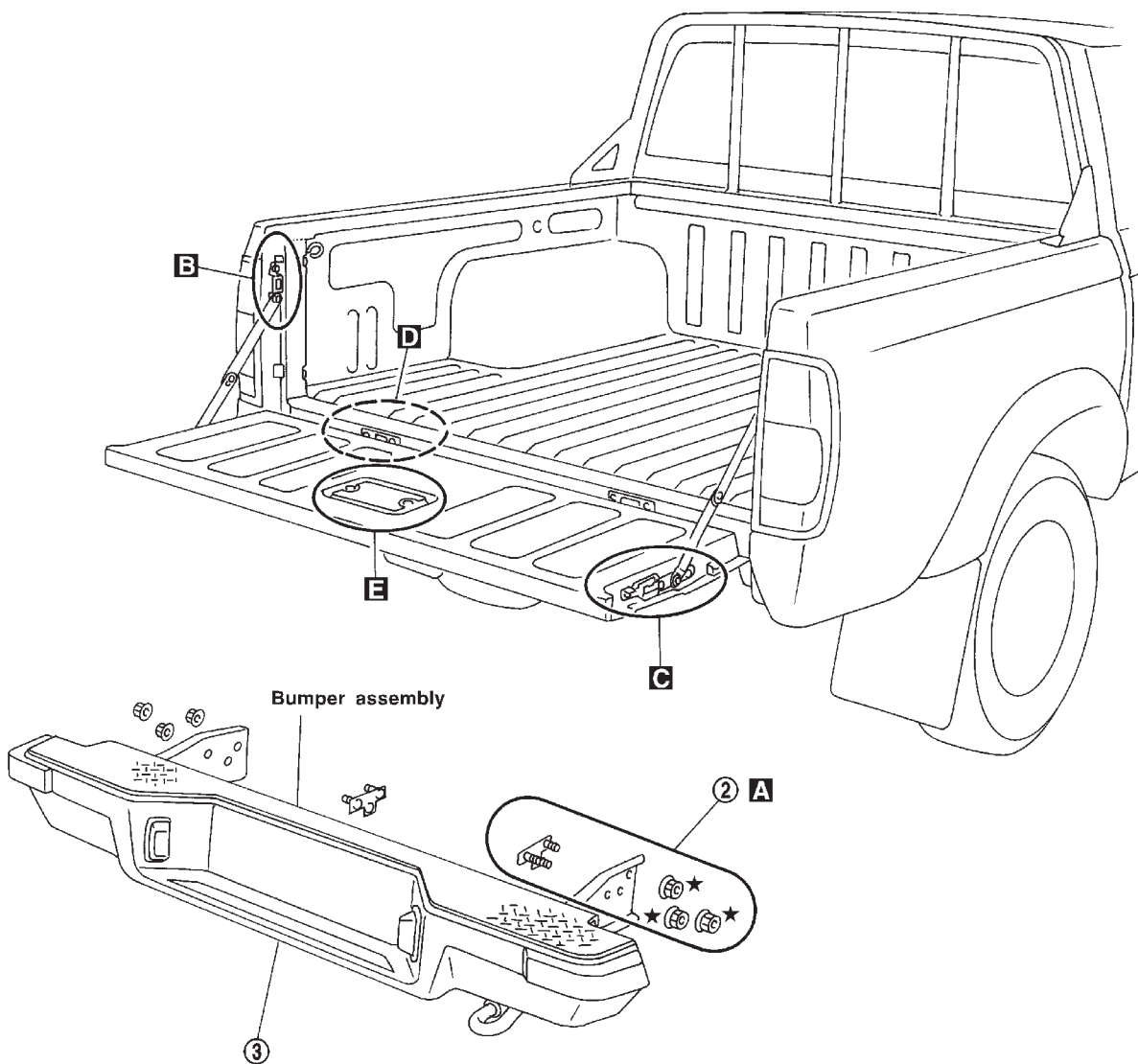



★ : Bumper assembly mounting nuts

SBT429

BODY END

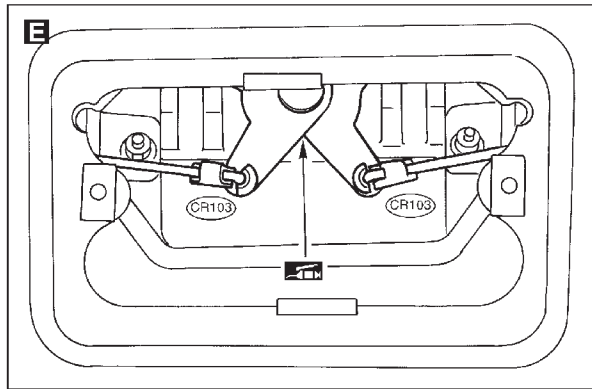
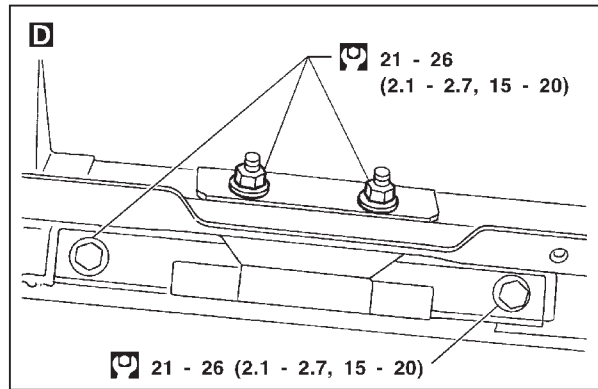
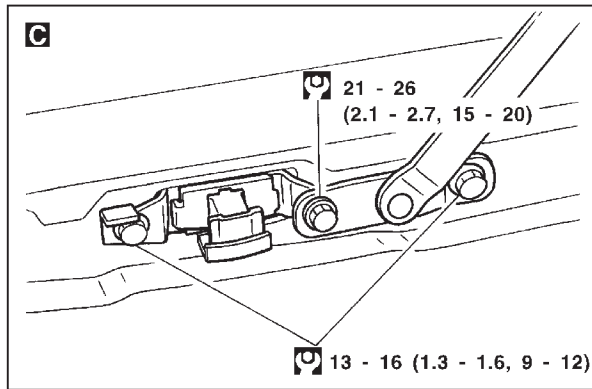
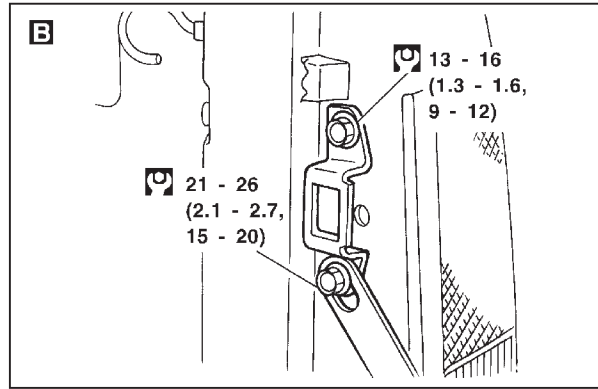
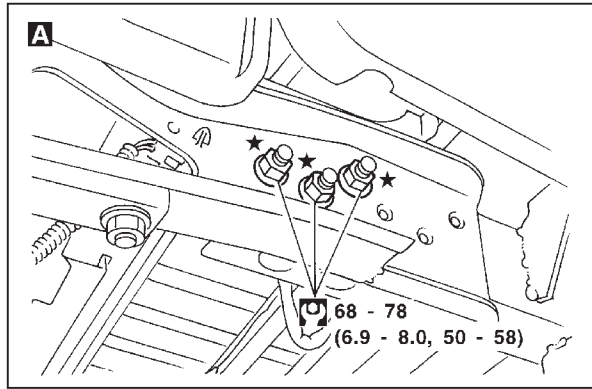
Body Rear End (Cont'd)



 : N·m (kg-m, ft-lb)

★ : Bumper assembly mounting bolts and nuts

GI
MA
EM
LC
EC
FE
CL
MT
TF
PD
FA
RA
BR
ST
RS
BT
HA
EL
IDX

DOOR

Front Door

- For removal of door trim, refer to "Door Trim" in "INTERIOR TRIM" for details, BT-18.
- After adjusting door or door lock, check door lock operation.

SEC. 800•803•805

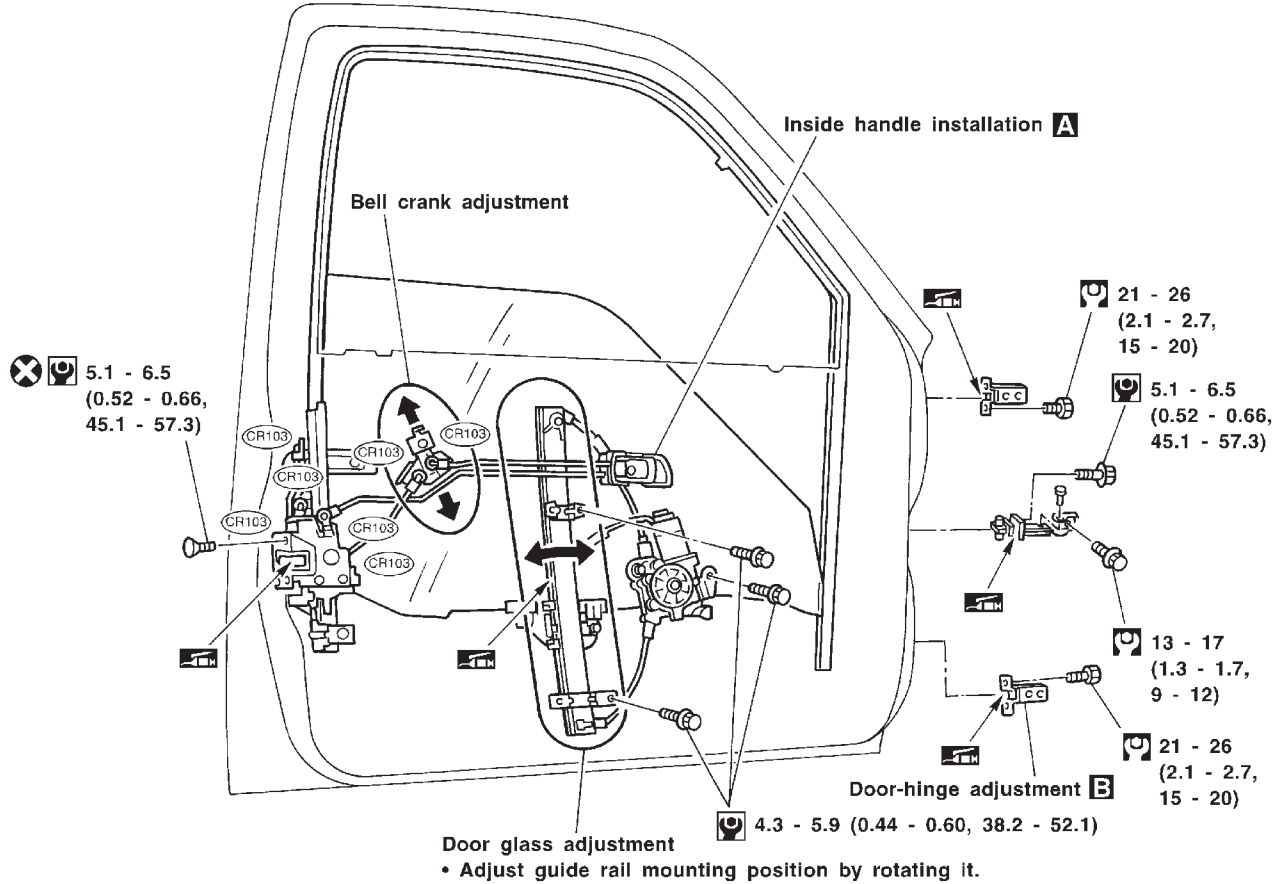

A Bell crank adjustment

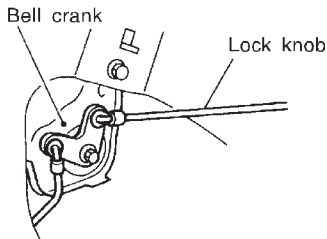

Lock door after setting door lock assembly and inside handle in position. Move bell crank in direction of arrow (shown in figure at left) to take up knob free play, and secure with bolts.

B Door-hinge adjustment

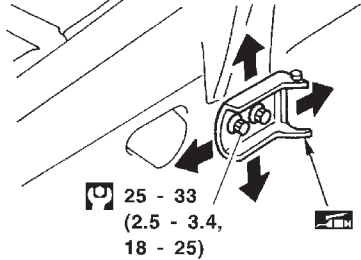

Striker adjustment

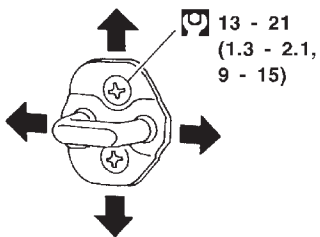

: N•m (kg-m, in-lb)

: N•m (kg-m, ft-lb)

DOOR

Rear Door

SEC. 820•823•825

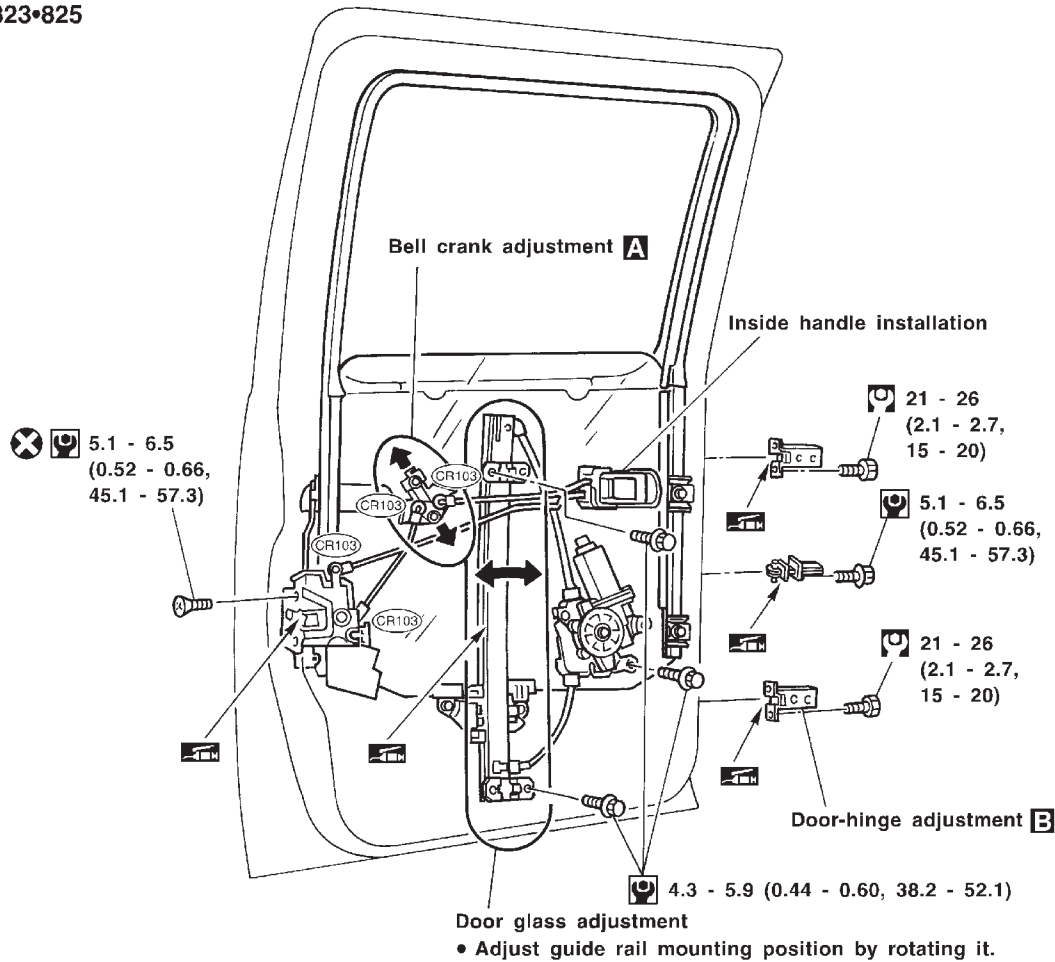

A Bell crank adjustment

Bell crank

Lock knob

Lock door after setting door lock assembly and inside handle in position. Move bell crank in direction of arrow (shown in figure at left) to take up knob free play, and secure with bolts.

B Door-hinge adjustment

25 - 33 (2.5 - 3.4, 18 - 25)

Striker adjustment

13 - 16 (1.3 - 1.6, 9 - 12)

: N•m (kg-m, in-lb)
 : N•m (kg-m, ft-lb)

GI
 MA
 EM
 LC
 EC
 FE
 CL
 MT
 TF
 PD
 FA
 RA
 BR
 ST
 RS
BT
 HA
 EL
 IDX

INSTRUMENT PANEL

CAUTION:

- Disconnect both terminals from battery in advance.
- Disconnect air bag module connector in advance.
- Be careful not to scratch finishers and other parts.
- Never tamper with or force air bag lid open, as this may adversely affect air bag performance.

REMOVAL — Instrument panel assembly

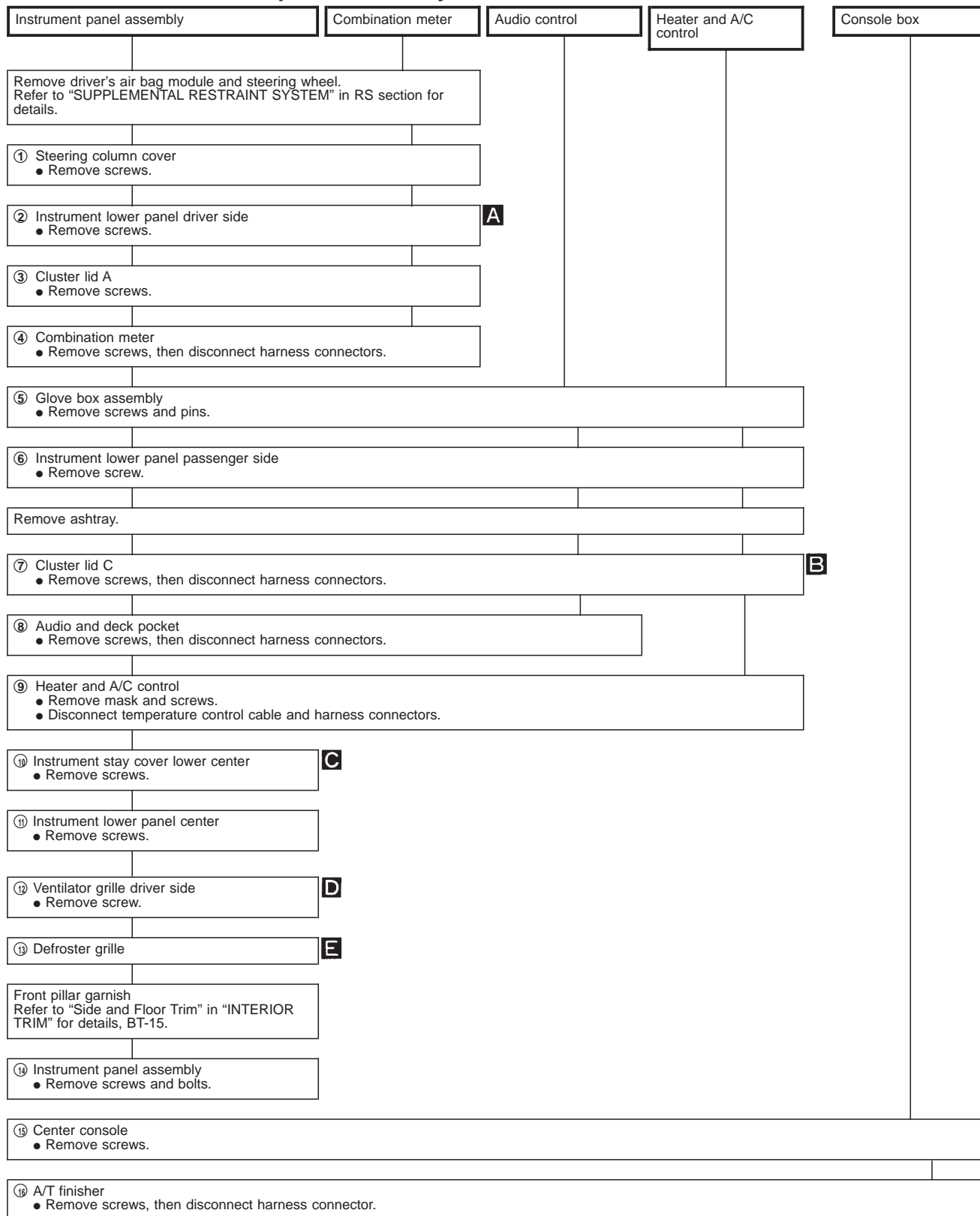

INSTRUMENT PANEL

SEC. 272•280•680•685•969

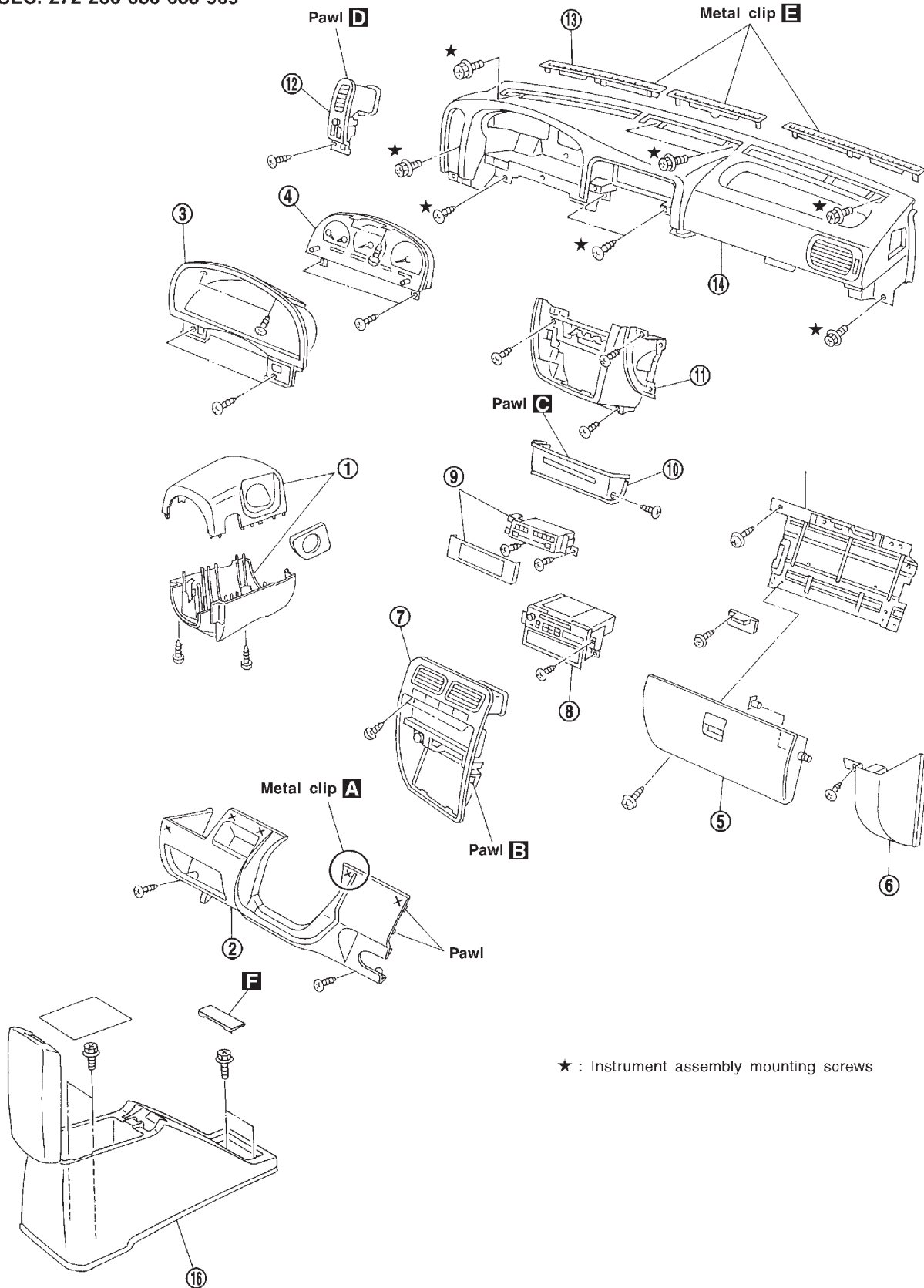

★ : Instrument assembly mounting screws

GI
MA
EM
LC
EC
FE
CL
MT
TF
PD
FA
RA
BR
ST
RS
BT
HA
EL
IDX

INSTRUMENT PANEL

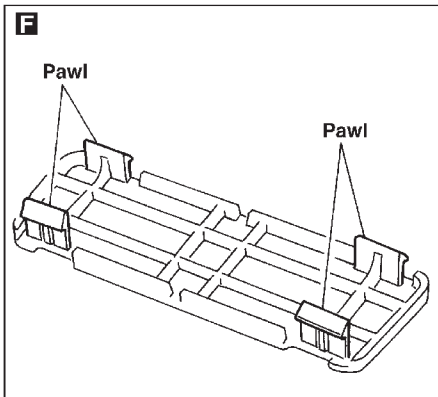
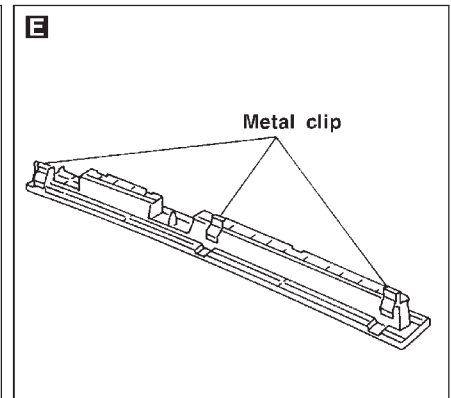
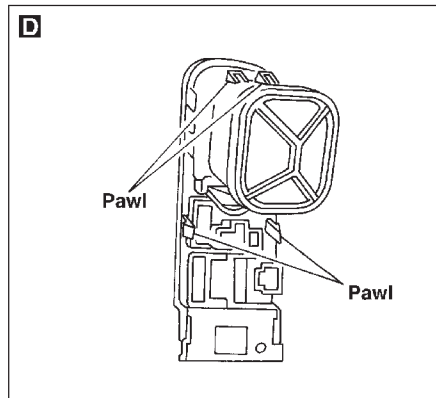
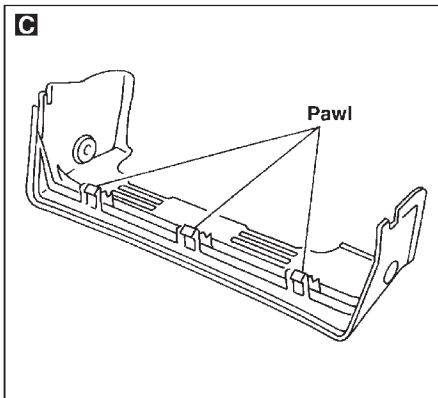
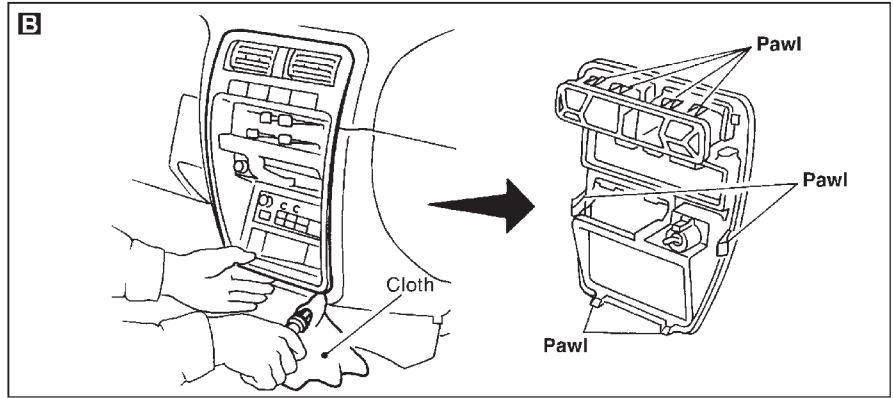
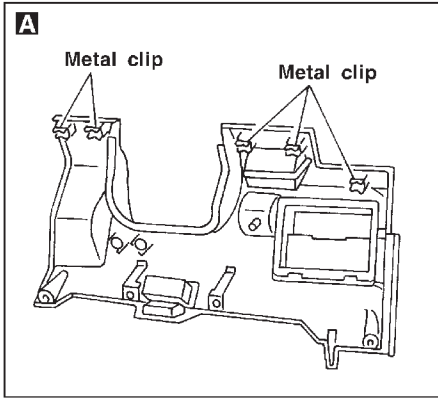

Side and Floor Trim

CAUTION:

Wrap the tip of flat-bladed screwdriver with a cloth when removing metal clips from garnishes.

REMOVAL — Body side trim

Double cab model

- ① Remove front and rear seats. Refer to “SEAT” for details, BT-28, 31.
- ② Remove front and rear kicking plates.
- ③ Remove dash side lower finishers.
- ④ Remove front and rear body side welts.
- ⑤ Remove front pillar garnishes.
- ⑥ Remove center pillar garnishes.
- ⑦ Remove lock pillar garnishes.

Single cab model

- ① Remove front seats. Refer to “SEAT” for details, BT-28.
- ② Remove kicking plates.
- ③ Remove dash side lower finishers.
- ④ Remove body side welts.
- ⑤ Remove front pillar garnishes.

GI

MA

EM

LC

EC

FE

CL

MT

TF

PD

FA

RA

BR

ST

RS

BT

HA

EL

IDX

INTERIOR TRIM

Side and Floor Trim (Cont'd)

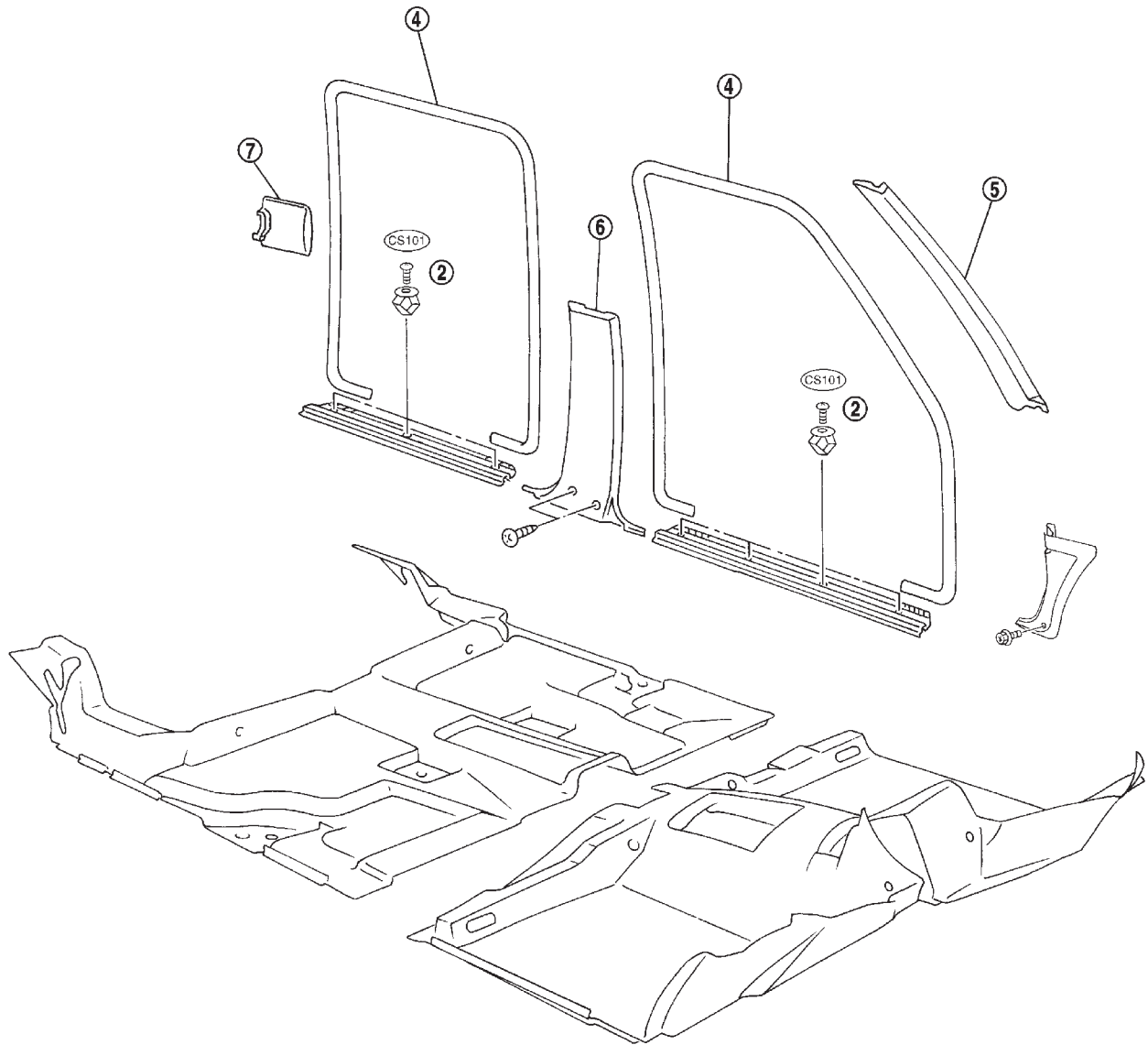

INTERIOR TRIM

Side and Floor Trim (Cont'd)

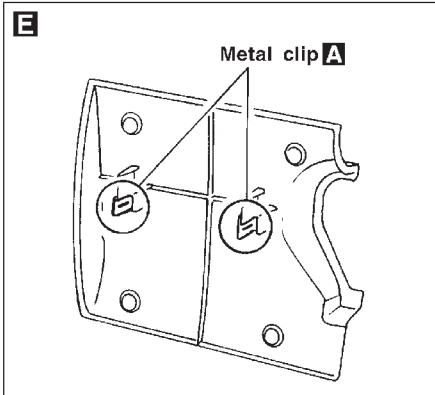
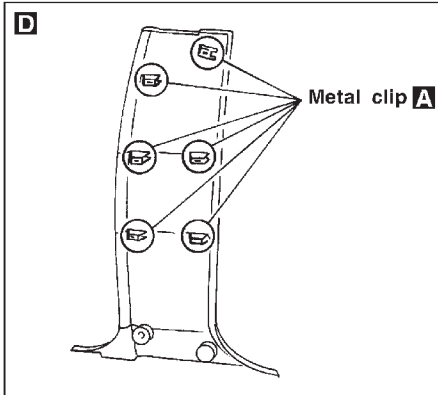
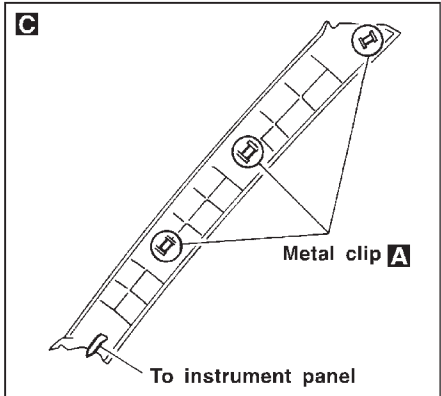
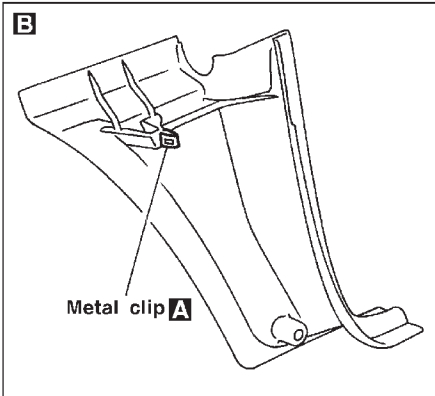
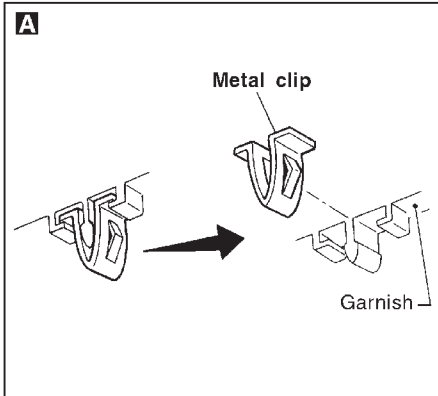

GI
MA
EM
LC
EC
FE
CL
MT
TF
PD
FA
RA
BR
ST
RS
BT
HA
EL
IDX

Door Trim

REMOVAL — Door trim

Front door trim

- ① Remove inside handle escutcheon. **A**
- ② Remove power window switch, then disconnect the connector. **B**
- ③ Remove door armrest. **C**
- ④ Remove screw securing pull handle and remove pull handle.
- ⑤ Remove bolt, screw and clip securing door finisher.
- ⑥ Lift out door finisher.

Rear door trim

- ⑦ Remove inside handle escutcheon. **A**
- ⑧ Remove screws securing door handle and remove door handle.
- ⑨ Lift out door finisher, then disconnect power window switch connector.

INTERIOR TRIM

Door Trim (Cont'd)

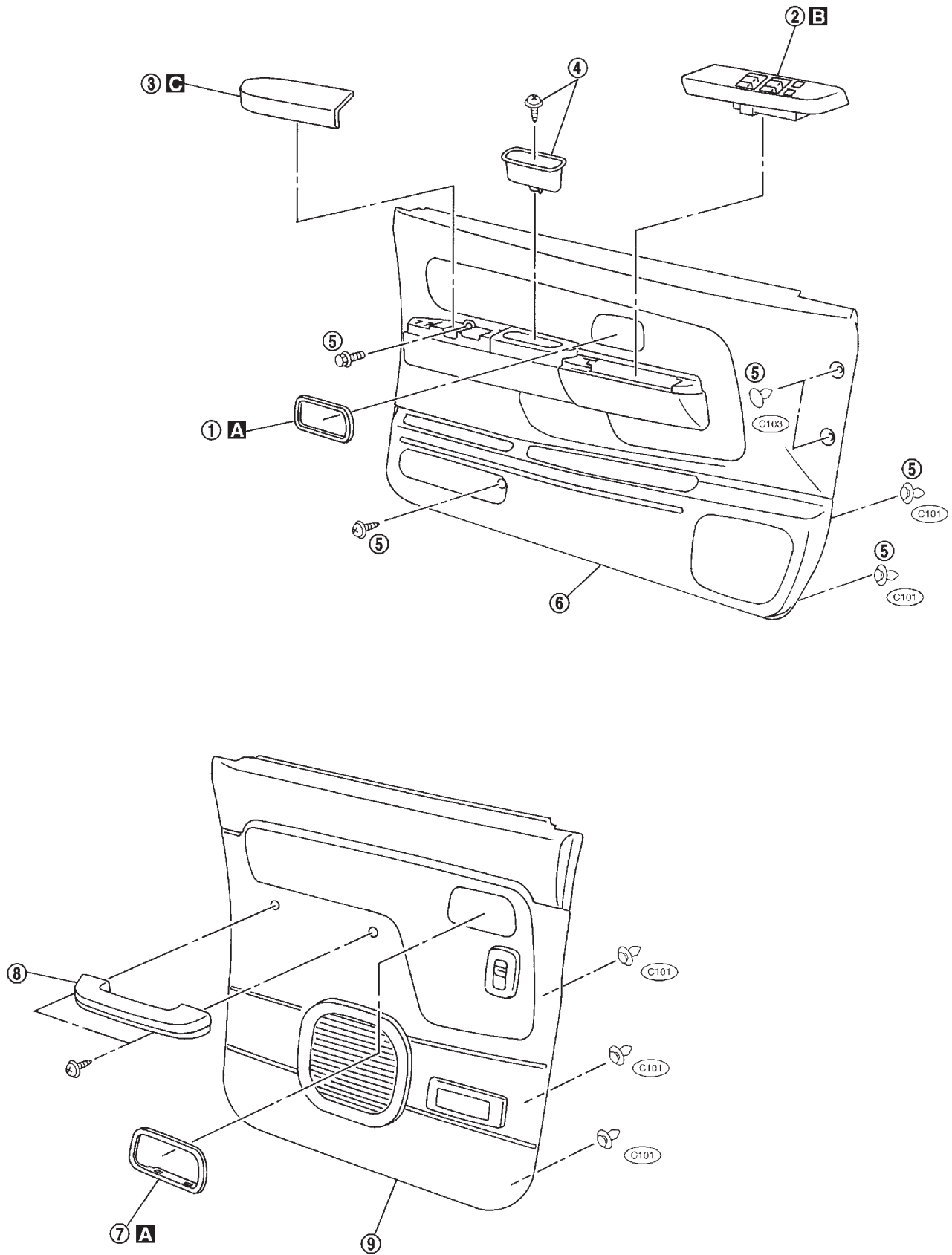

GI
MA
EM
LC
EC
FE
CL
MT
TF
PD
FA
RA
BR
ST
RS
BT
HA
EL
IDX

INTERIOR TRIM

Door Trim (Cont'd)

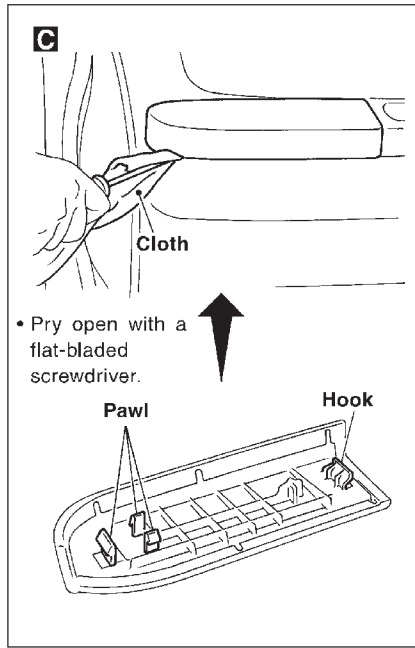
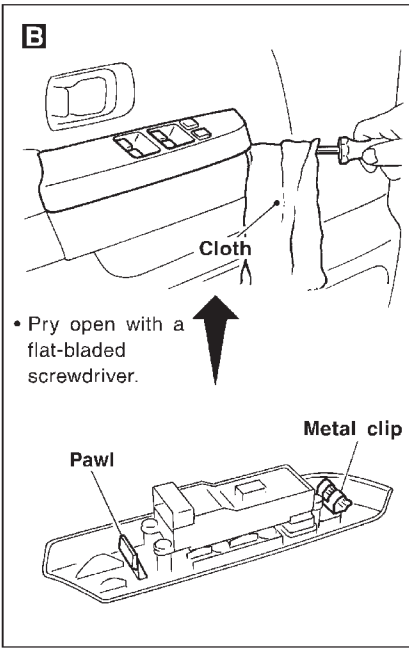
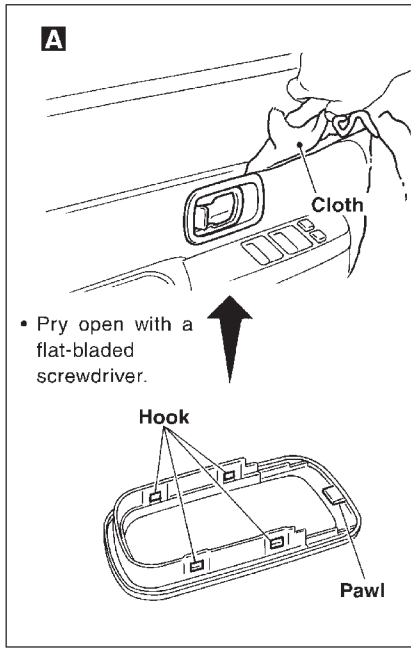

INTERIOR TRIM

Roof Trim

REMOVAL — Headlining

- ① Remove front and rear seats. Refer to “SEAT” for details, BT-28, 31.
- ② Remove front seat belt. Refer to “SEAT BELTS” in RS section for details.
- ③ Remove body side trim. Refer to “Side and Floor Trim” for details, BT-15.
- ④ Remove sun visors.
- ⑤ Remove inside mirror assembly.
- ⑥ Remove interior lamp assembly. **A**
- ⑦ Remove assist grips.
- ⑧ Remove rear window weatherstrip and remove rear window glass. **B**
- ⑨ Remove sunroof welt.
- ⑩ Remove welt. **C**
- ⑪ Remove headlining.

SEC. 738•963•964•970

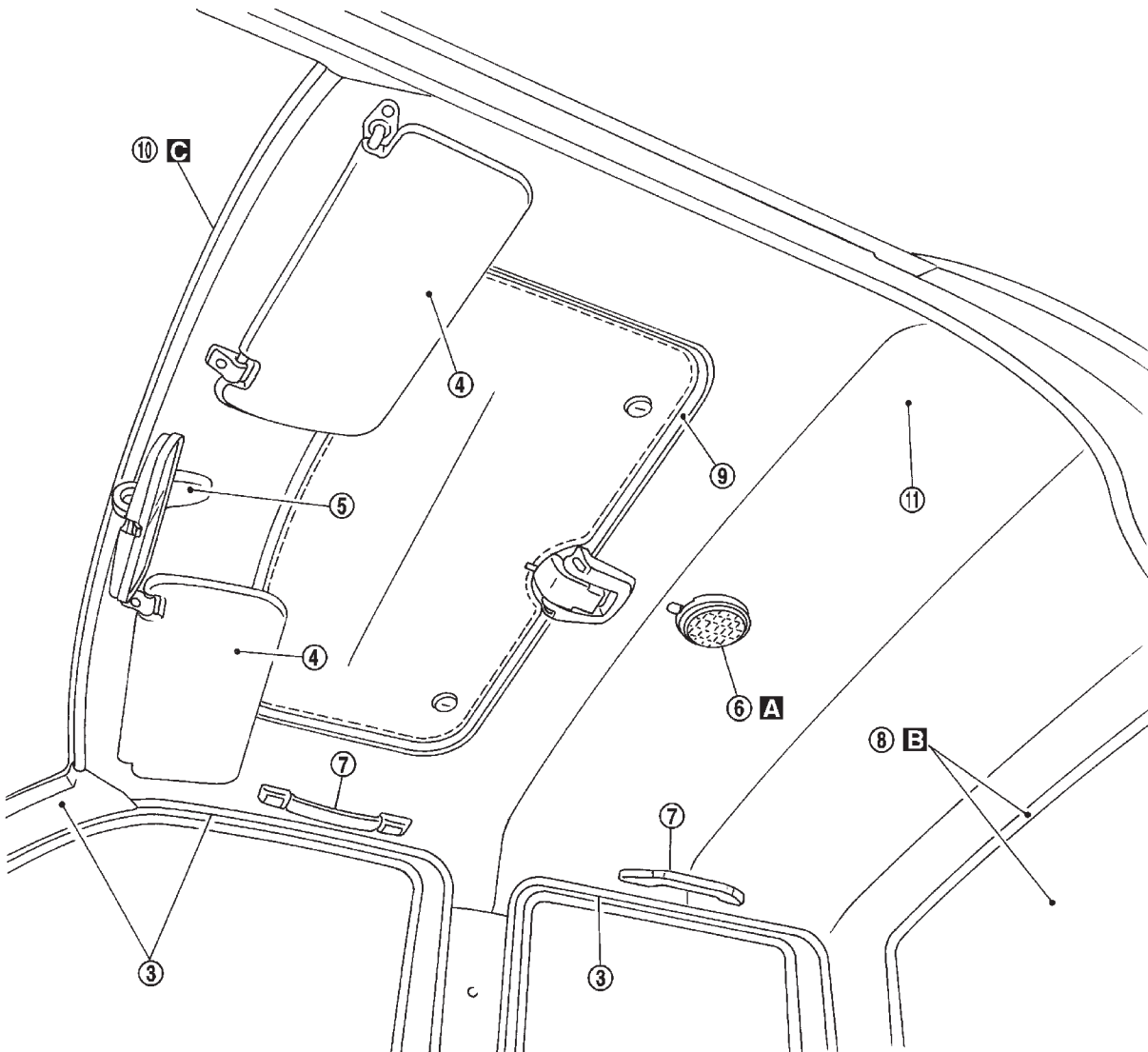

GI
MA
EM
LC
EC
FE
CL
MT
TF
PD
FA
RA
BR
ST
RS
BT
HA
EL
IDX

SBT439

INTERIOR TRIM

Roof Trim (Cont'd)

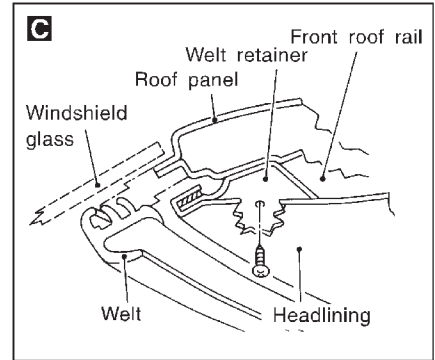
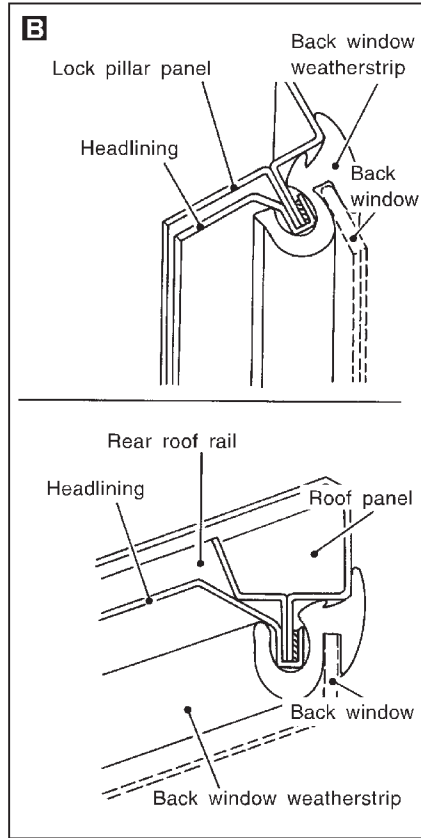
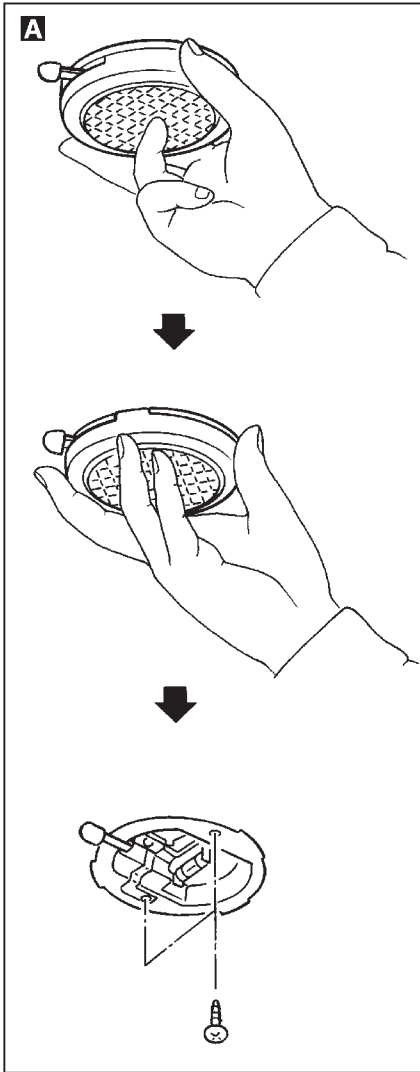

 : Double-faced adhesive tape

EXTERIOR

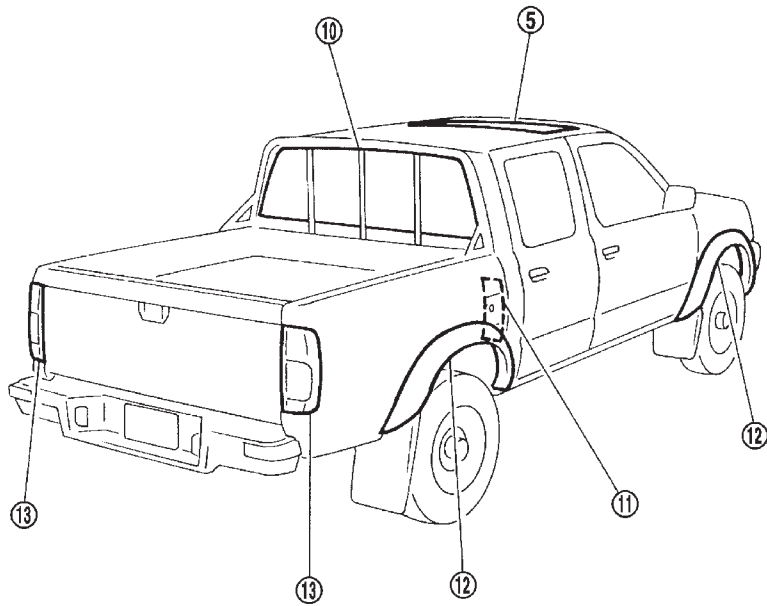
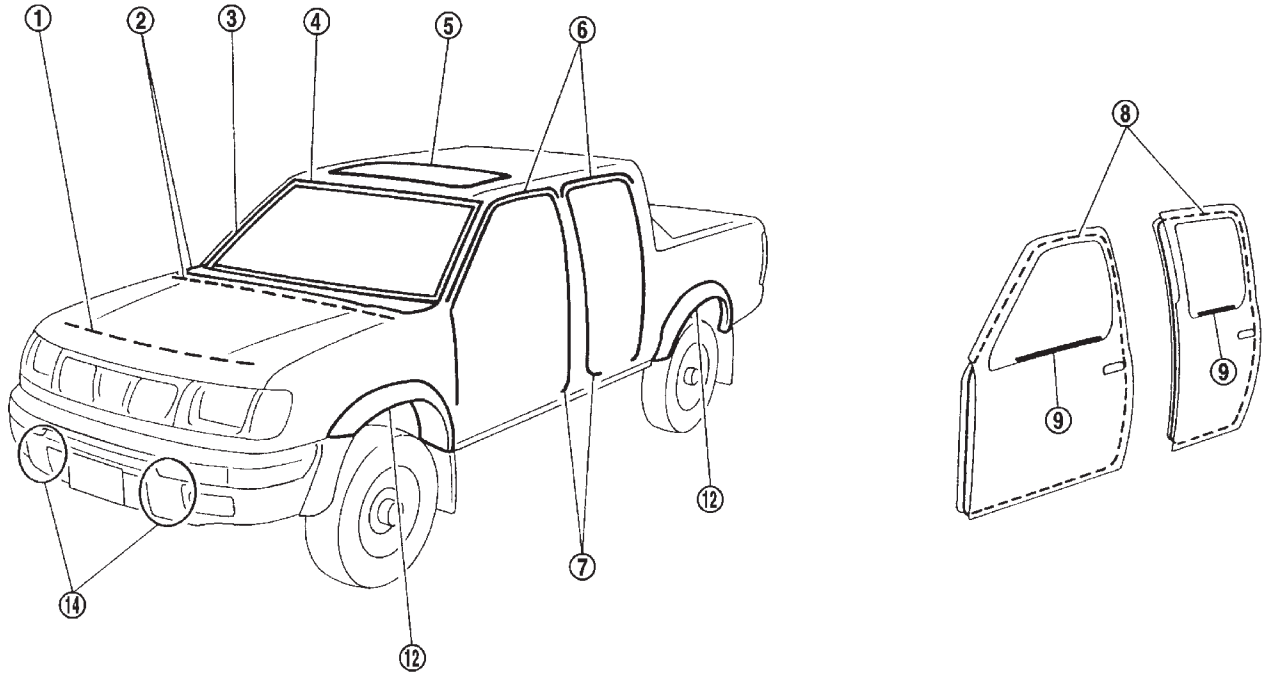

GI
MA
EM
LC
EC
FE
CL
MT
TF
PD
FA
RA
BR
ST
RS
BT
HA
EL
IDX

① Hood front sealing rubber

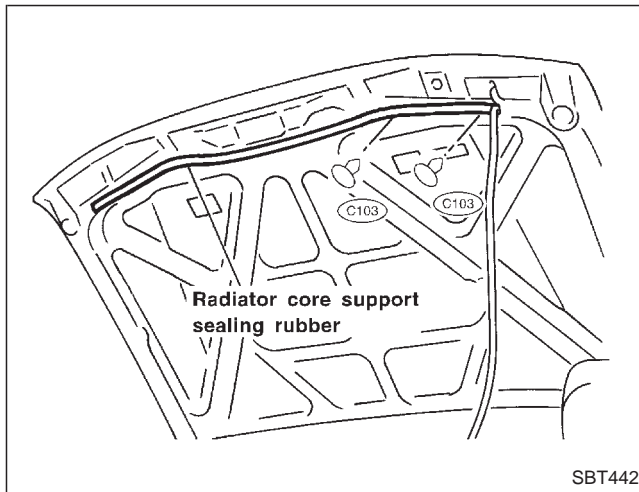

② Cowl top seal and cowl top grille

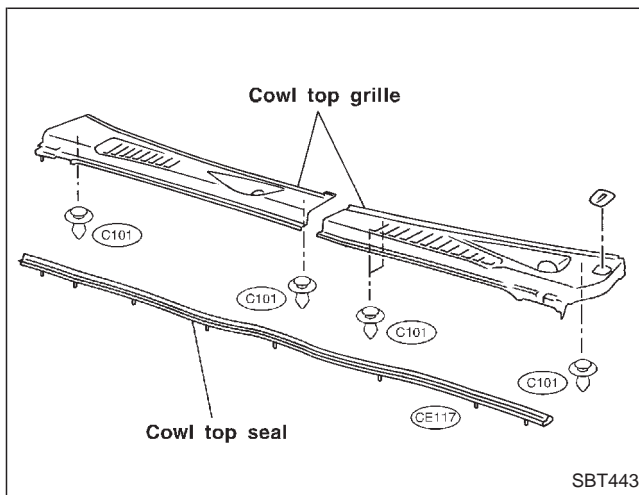

③ Windshield side molding

Mounted with screws.

④ Windshield upper molding

SEC. 720

1. Cut off urethane adhesive at glass end.
2. Remove old urethane adhesive from panel surface.
3. Set molding fastener and apply primer to body panel, and apply urethane adhesive to body.

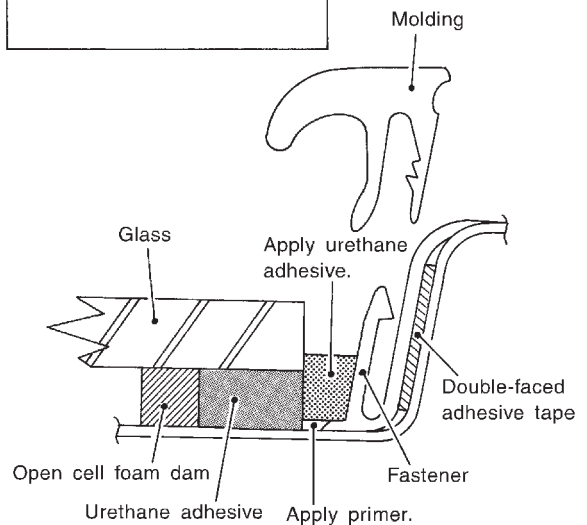
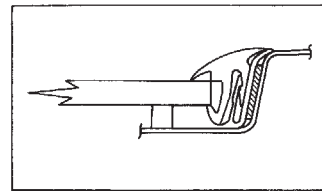

4. Install molding by aligning the molding mark located on center with vehicle center. Be sure to install tightly so that there is no gap around the corner.

SBT444-A

⑤ Sunroof weatherstrip and lid protector

SEC. 736

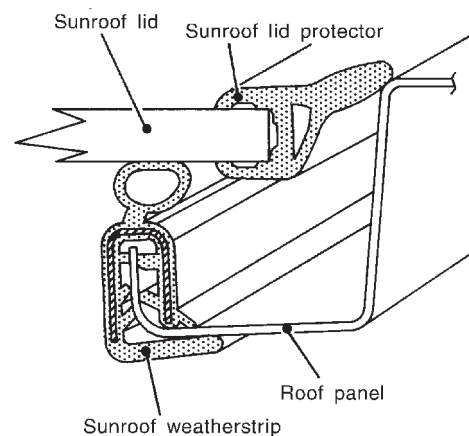

SBT445

⑥ Drip weatherstrip

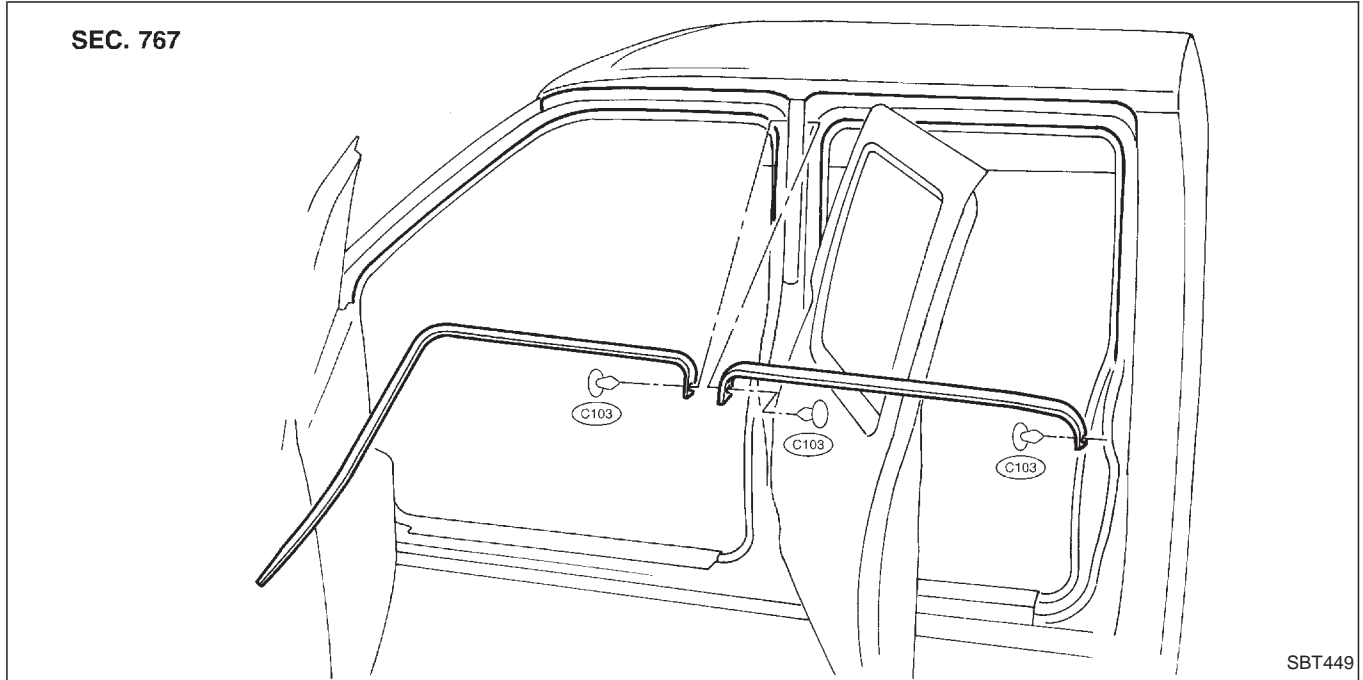

⑦ Body side welt

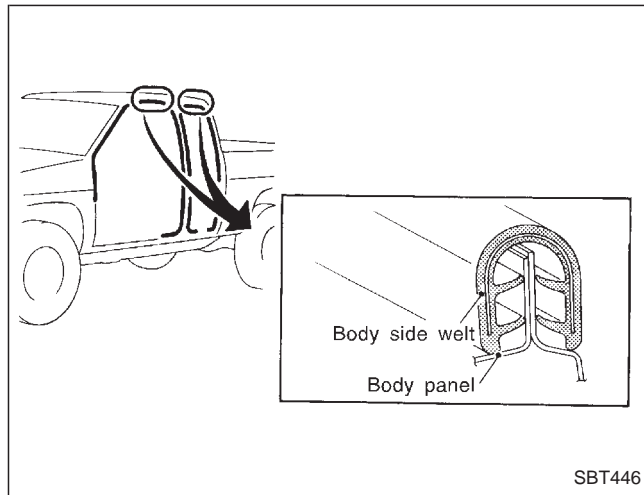

⑨ Door outside molding

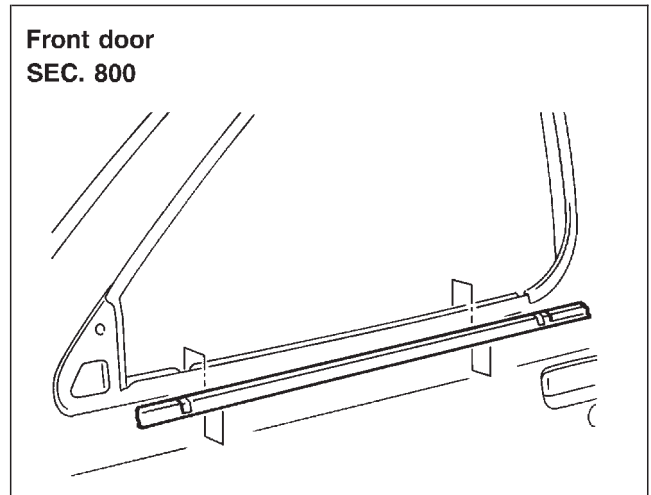

⑧ Door weatherstrip

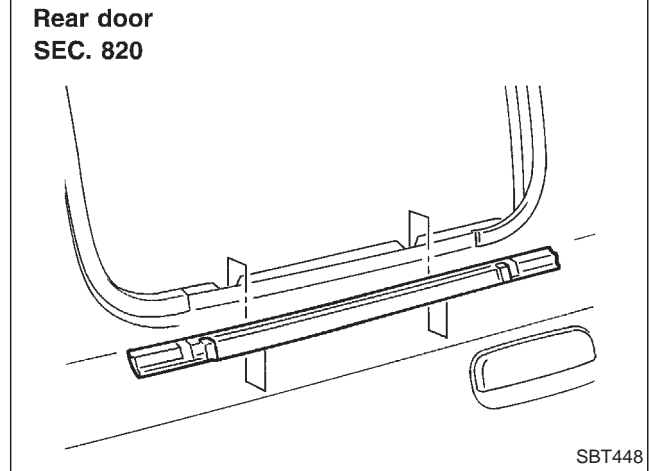
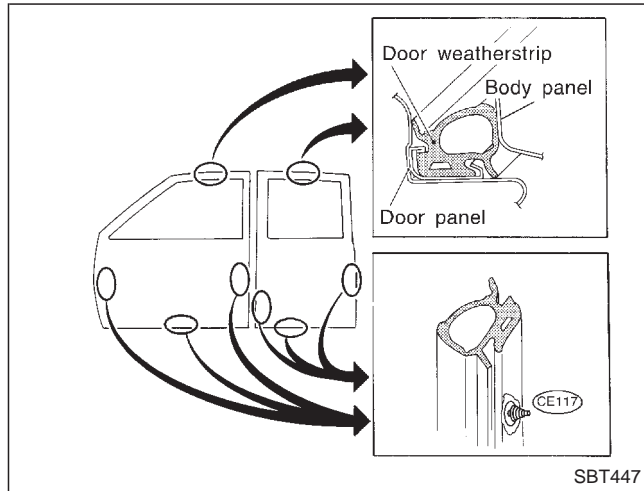

GI
MA
EM
LC
EC
FE
CL
MT
TF
PD
FA
RA
BR
ST
RS
BT
HA
EL
IDX

EXTERIOR

⑩ Back window

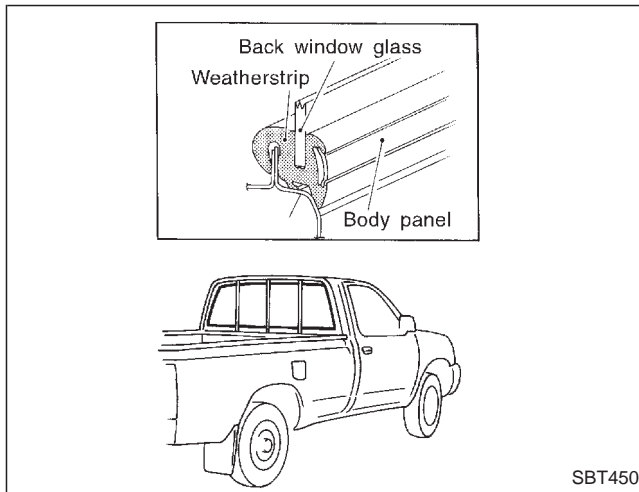

⑪ Drafter duct

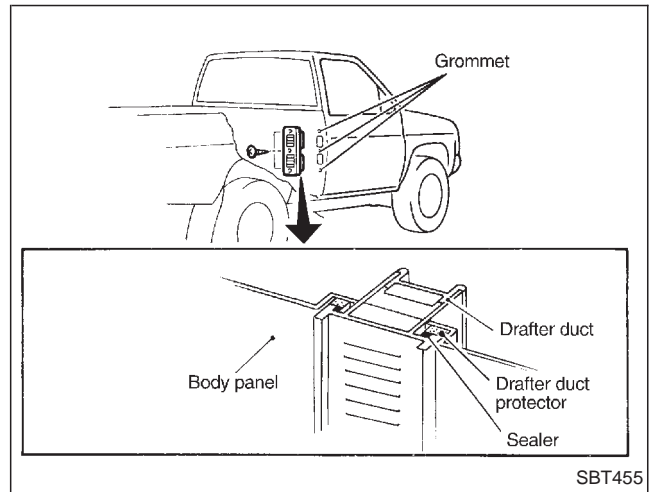

⑫ Over fender

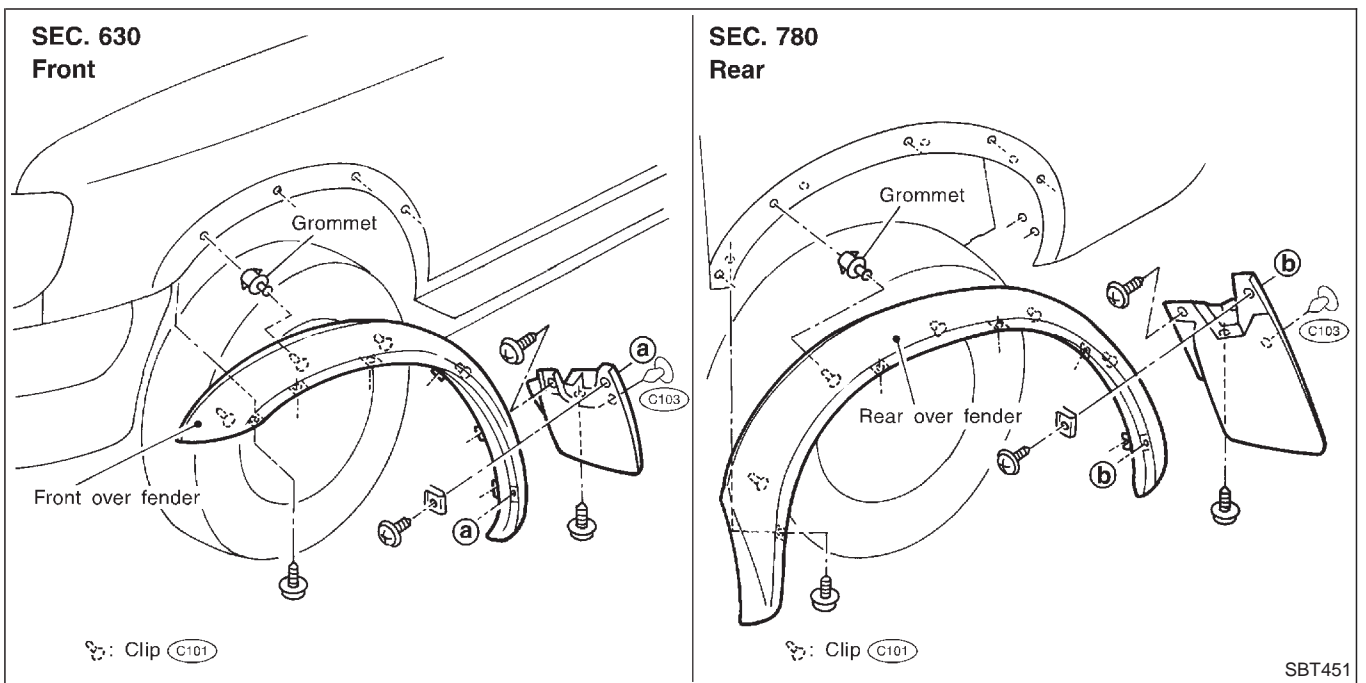

⑬ Rear combination lamp

Mounted with bolts.

⑭ Overrider

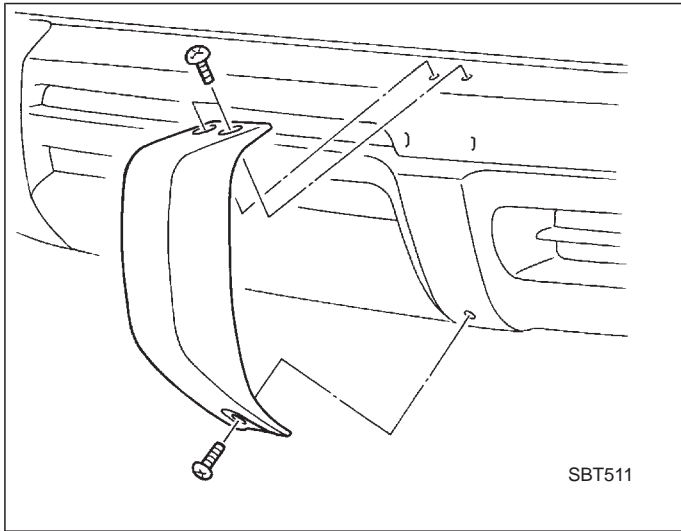

GI

MA

EM

LC

EC

FE

CL

MT

TF

PD

FA

RA

BR

ST

RS

BT

HA

EL

IDX

SEAT

- When removing or installing the seat trim, carefully handle it to keep dirt out and avoid damage.

Front Seat

SEC. 868•870

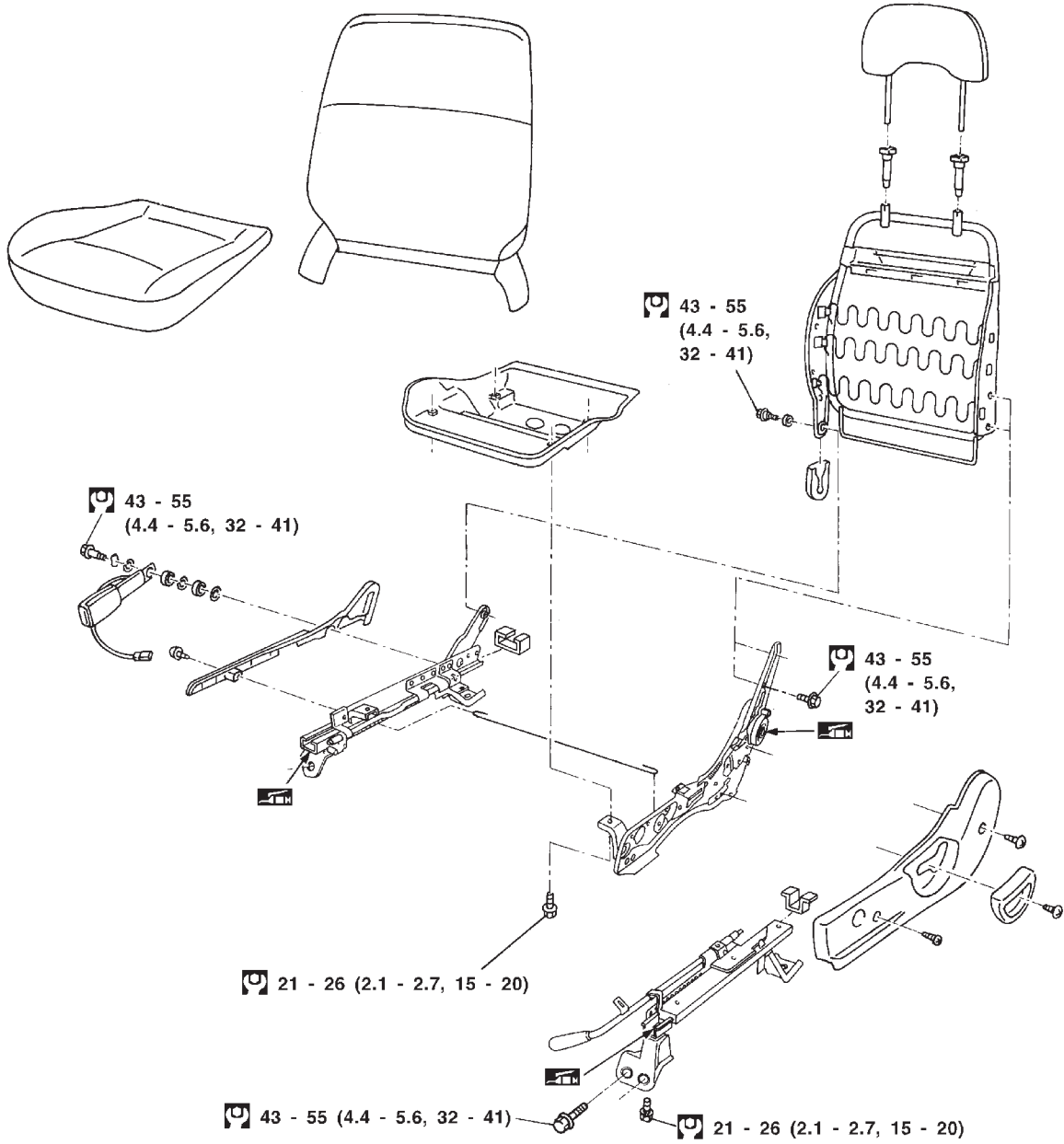

 : N•m (kg-m, ft-lb)

SEAT

Front Seat (Cont'd)

SEC. 870

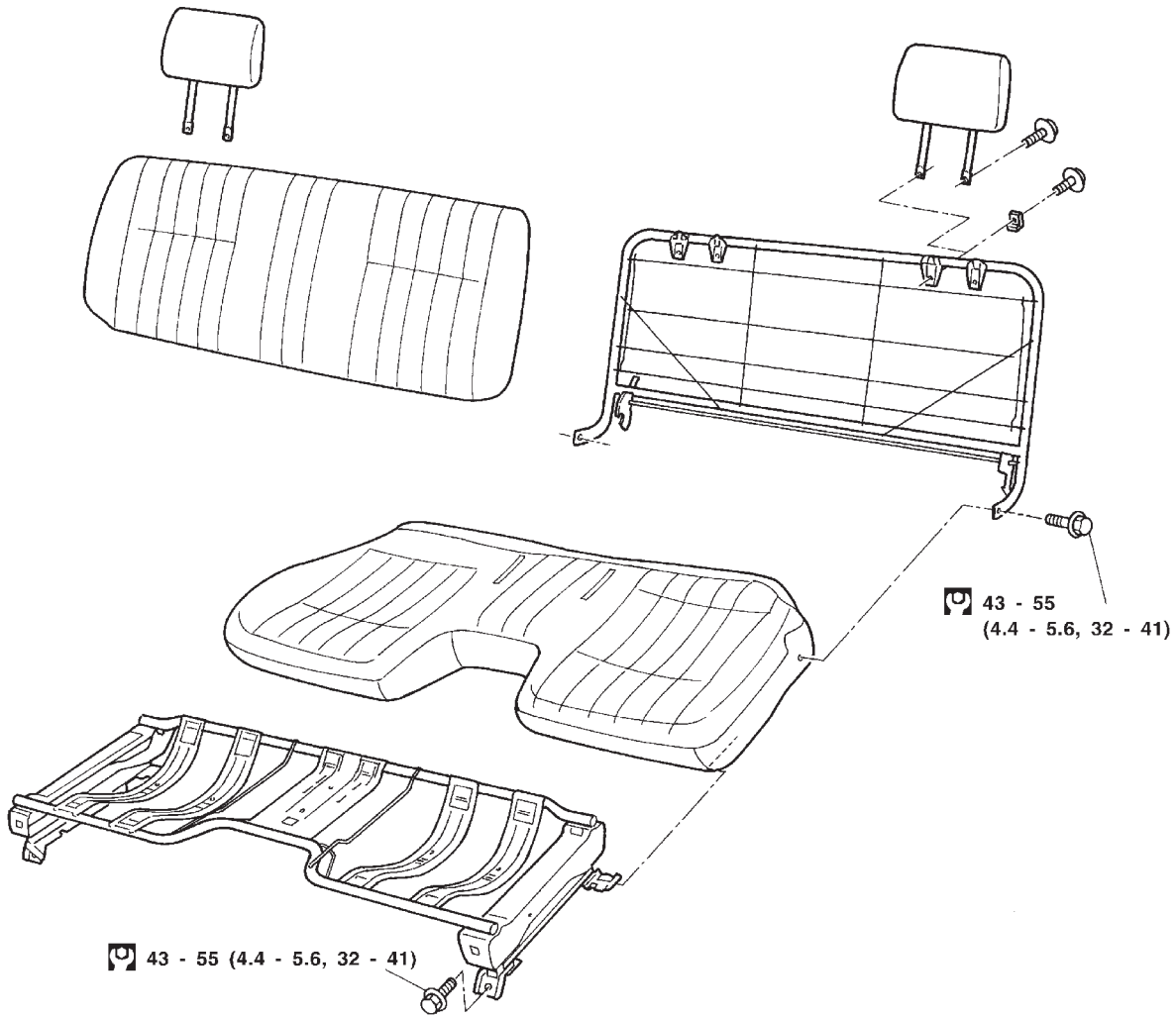

⊕ : N•m (kg-m, ft-lb)

GI
MA
EM
LC
EC
FE
CL
MT
TF
PD
FA
RA
BR
ST
RS
BT
HA
EL
IDX

Heated Seat

- When handling seat, be extremely careful not to scratch heating unit.
- To replace heating unit, seat trim and pad should be separated.
- Do not use any organic solvent, such as thinner, benzene, alcohol, gasoline, etc. to clean trims.

Seatback heating unit removal & installation

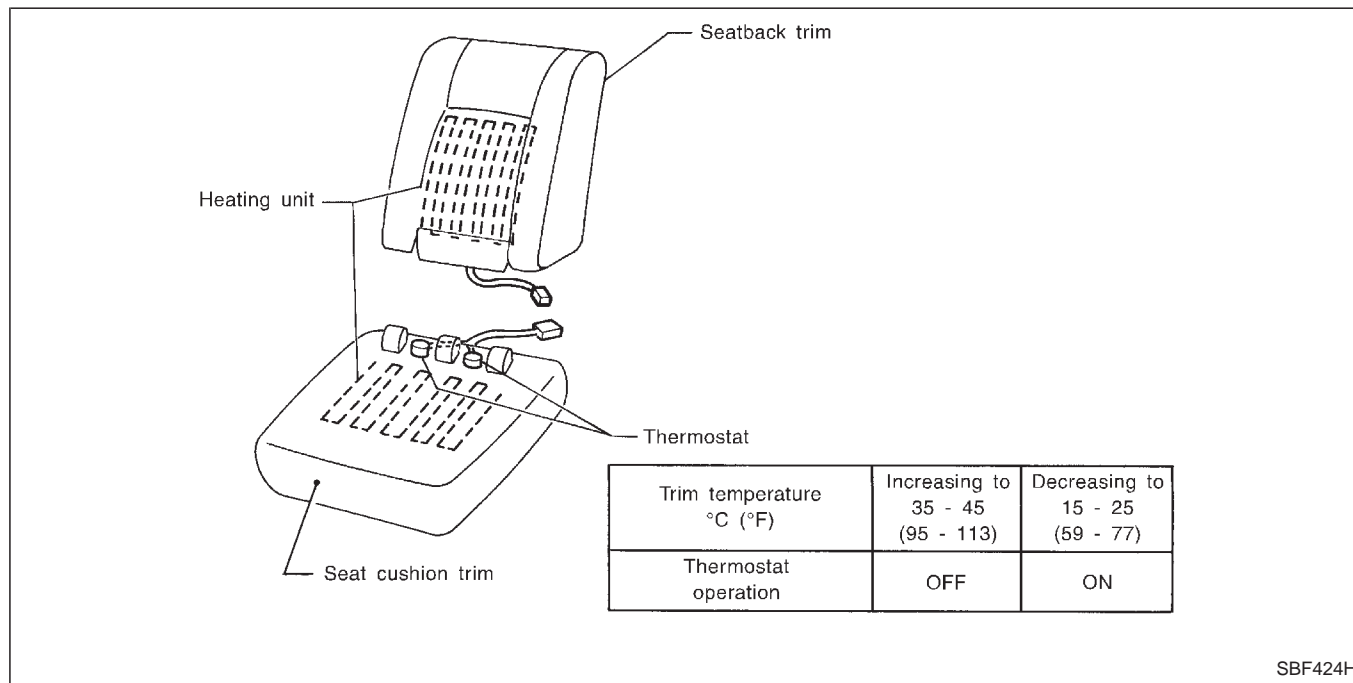

SBF424H

★ For Wiring Diagram, refer to “HEATED SEAT” in EL section.

Rear Seat

SEC. 880

Seatback lock

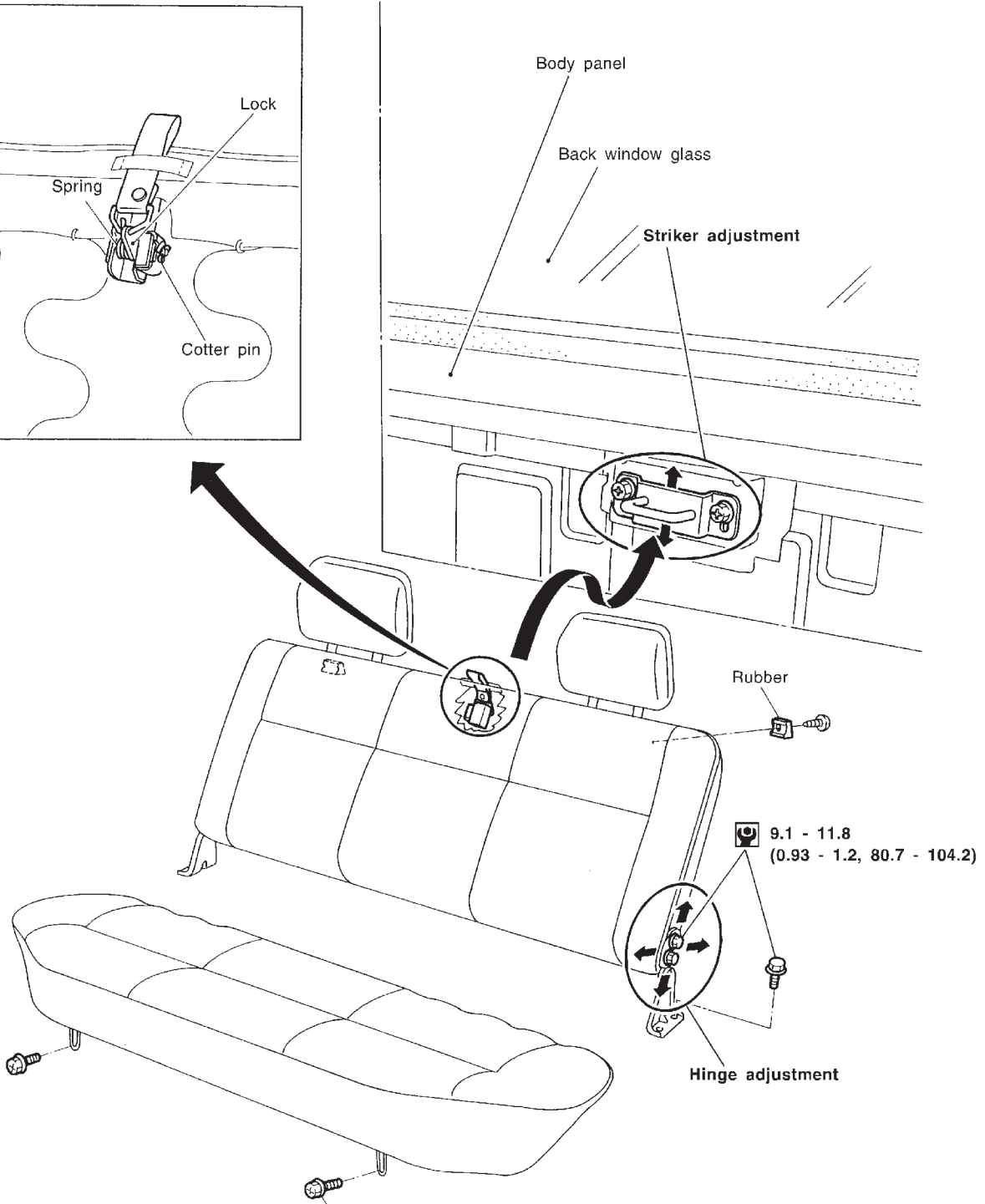
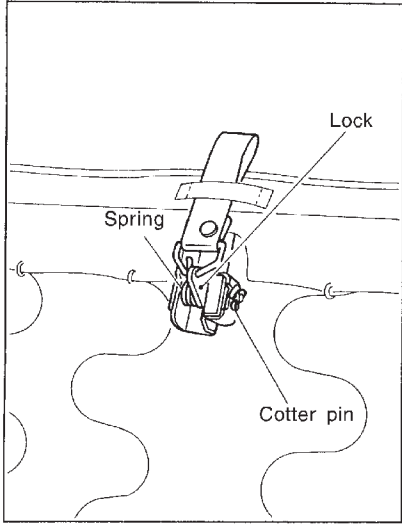

: N·m (kg-m, in-lb)

3.7 - 4.3 (0.38 - 0.44, 33.0 - 38.2)

GI
MA
EM
LC
EC
FE
CL
MT
TF
PD
FA
RA
BR
ST
RS
BT
HA
EL
IDX

SUNROOF

SEC. 736

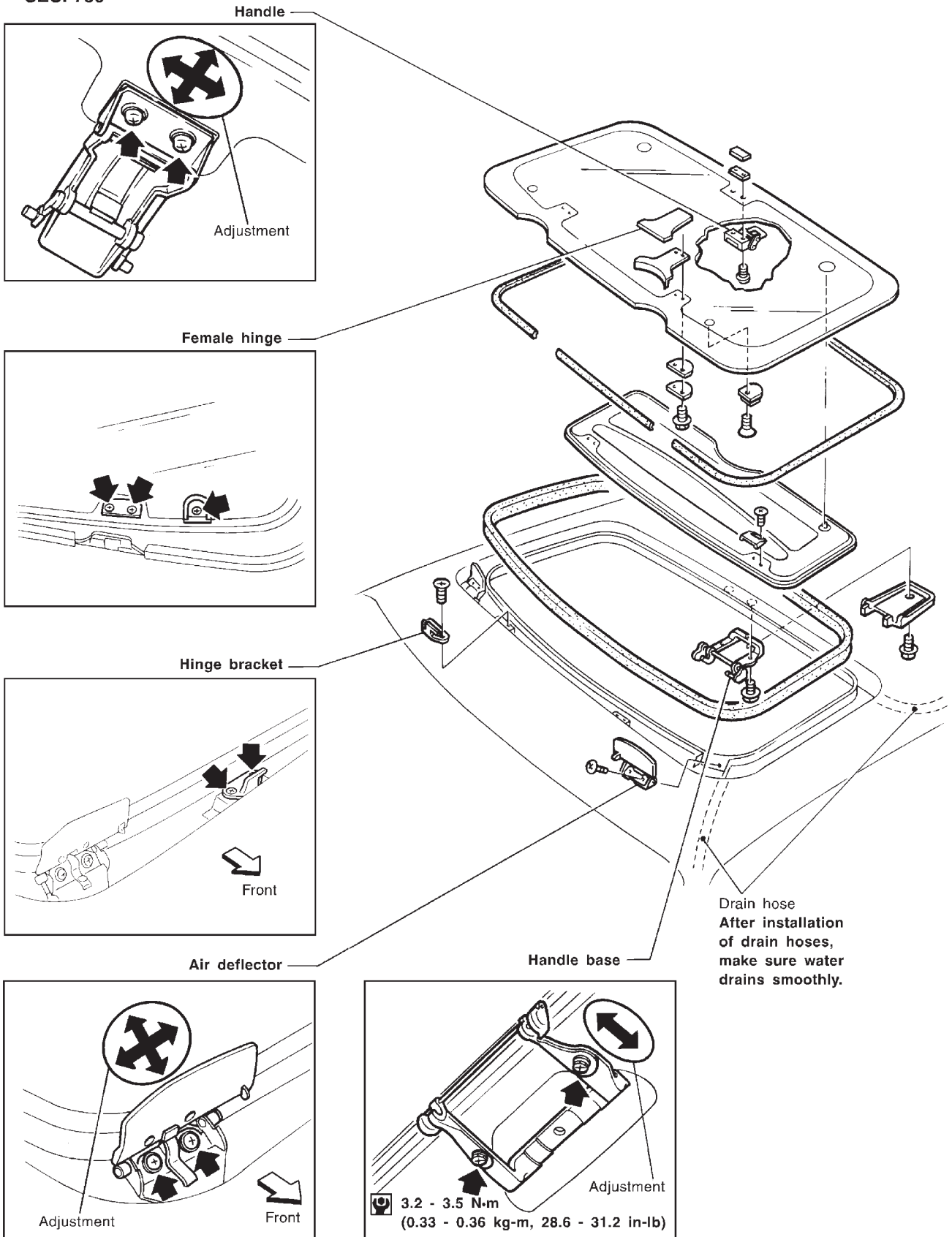

WINDSHIELD AND WINDOWS

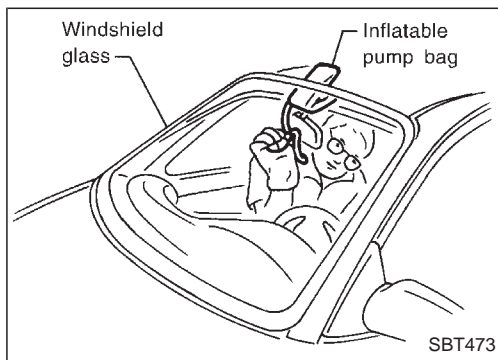
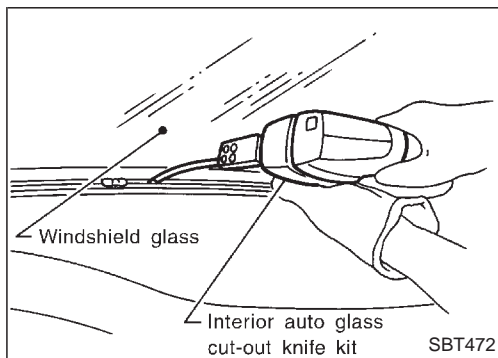
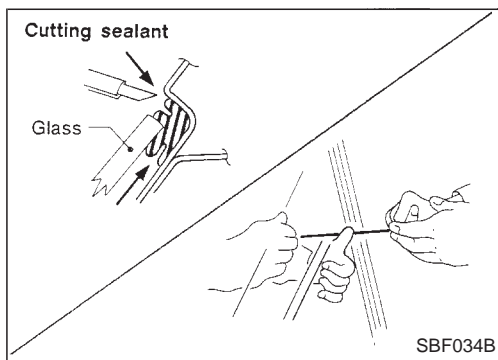

REMOVAL

After removing moldings, remove glass using piano wire or power cutting tool and an inflatable pump bag.

WARNING:

When cutting the glass from the vehicle, always wear safety glasses and heavy gloves to help prevent glass splinters from entering your eyes or cutting your hands.

CAUTION:

- Be careful not to scratch the glass when removing.
- Do not set or stand the glass on its edge. Small chips may develop into cracks.

INSTALLATION

- Use a genuine Nissan Urethane Adhesive Kit or equivalent and follow the instructions furnished with it.
- While the urethane adhesive is curing, open a door window. This will prevent the glass from being forced out by passenger compartment air pressure when a door is closed.
- The molding must be installed securely so that it is in position and leaves no gap.
- Inform the customer that the vehicle should remain stationary until the urethane adhesive has completely cured (preferably 24 hours). Curing time varies with temperature and humidity.

WARNING:

- Keep heat and open flames away as primers and adhesive are flammable.
- The materials contained in the kit are harmful if swallowed, and may irritate skin and eyes. Avoid contact with the skin and eyes.
- Use in an open, well ventilated location. Avoid breathing the vapors. They can be harmful if inhaled. If affected by vapor inhalation, immediately move to an area with fresh air.
- Driving the vehicle before the urethane adhesive has completely cured may affect the performance of the windshield in case of an accident.

CAUTION:

- Do not use an adhesive which is past its usable term. Shelf life of this product is limited to six months after the date of manufacture. Carefully adhere to the expiration or manufacture date printed on the box.
- Keep primers and adhesive in a cool, dry place. Ideally, they should be stored in a refrigerator.
- Do not leave primers or adhesive cartridge unattended with their caps open or off.
- The vehicle should not be driven for at least 24 hours or until the urethane adhesive has completely cured. Curing time varies depending on temperature and humidities. The curing time will increase under higher temperatures and lower humidities.

GI

MA

EM

LC

EC

FE

CL

MT

TF

PD

FA

RA

BR

ST

RS

BT

HA

EL

IDX

WINDSHIELD AND WINDOWS

Windshield

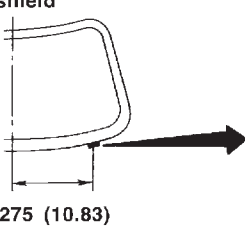
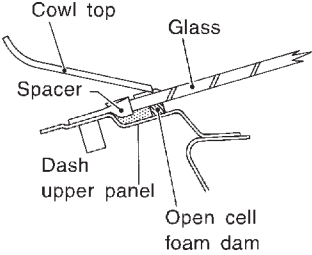
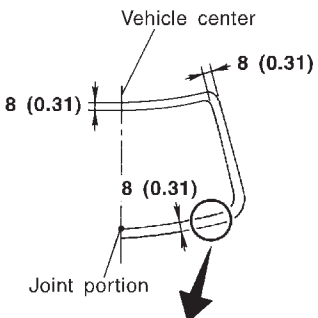
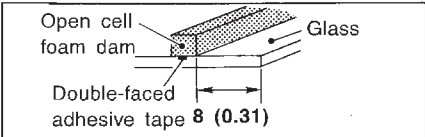
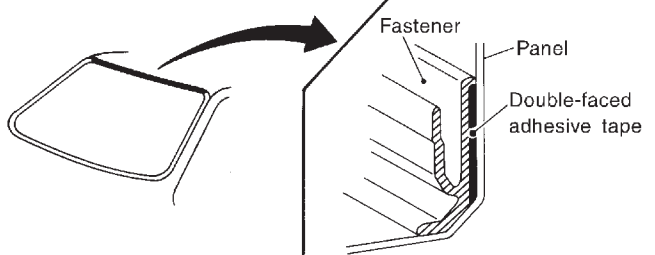
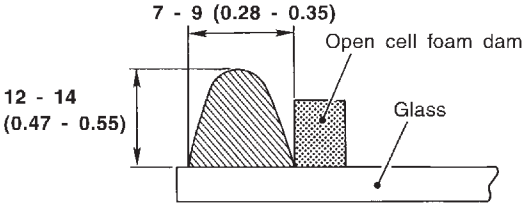
<p>Body side Install spacer to panel.</p> <p>Windshield</p>  <p>275 (10.83)</p>	 <p>Cowl top Glass Spacer Dash upper panel Open cell foam dam</p>	<p>Glass side Install open cell foam dam. Windshield</p>  <p>Vehicle center 8 (0.31) 8 (0.31) Joint portion</p>  <p>Open cell foam dam Glass Double-faced adhesive tape 8 (0.31)</p>
<p>Install molding fastener. When installing it, heat body panel and fastener to approx. 30 to 40°C (86 to 104°F).</p> <p>Upper & side molding fasteners</p>  <p>Fastener Panel Double-faced adhesive tape</p>	<p>Apply urethane adhesive evenly. Windshield and rear window</p>  <p>7 - 9 (0.28 - 0.35) Open cell foam dam Glass 12 - 14 (0.47 - 0.55)</p> <p>Unit: mm (in) SBT457-A</p>	

REPAIRING WATER LEAKS FOR WINDSHIELD

Leaks can be repaired without removing and reinstalling glass.

If water is leaking between urethane adhesive material and body or glass, determine the extent of leakage. This can be done by applying water to the windshield area while pushing glass outward.

To stop the leak, apply primer (if necessary) and then urethane adhesive to the leak point.

MIRROR

Door Mirror

CAUTION:

Be careful not to scratch door rearview mirror body.

★ For Wiring Diagram, refer to "POWER DOOR MIRROR" in EL section.

REMOVAL — Door mirror

- ① Remove door trim. Refer to "Door Trim" for details, BT-18.
- ② Remove inner cover from front corner of door.
- ③ Disconnect door mirror harness connector.
- ④ Remove bolts securing door mirror, then remove door mirror assembly.

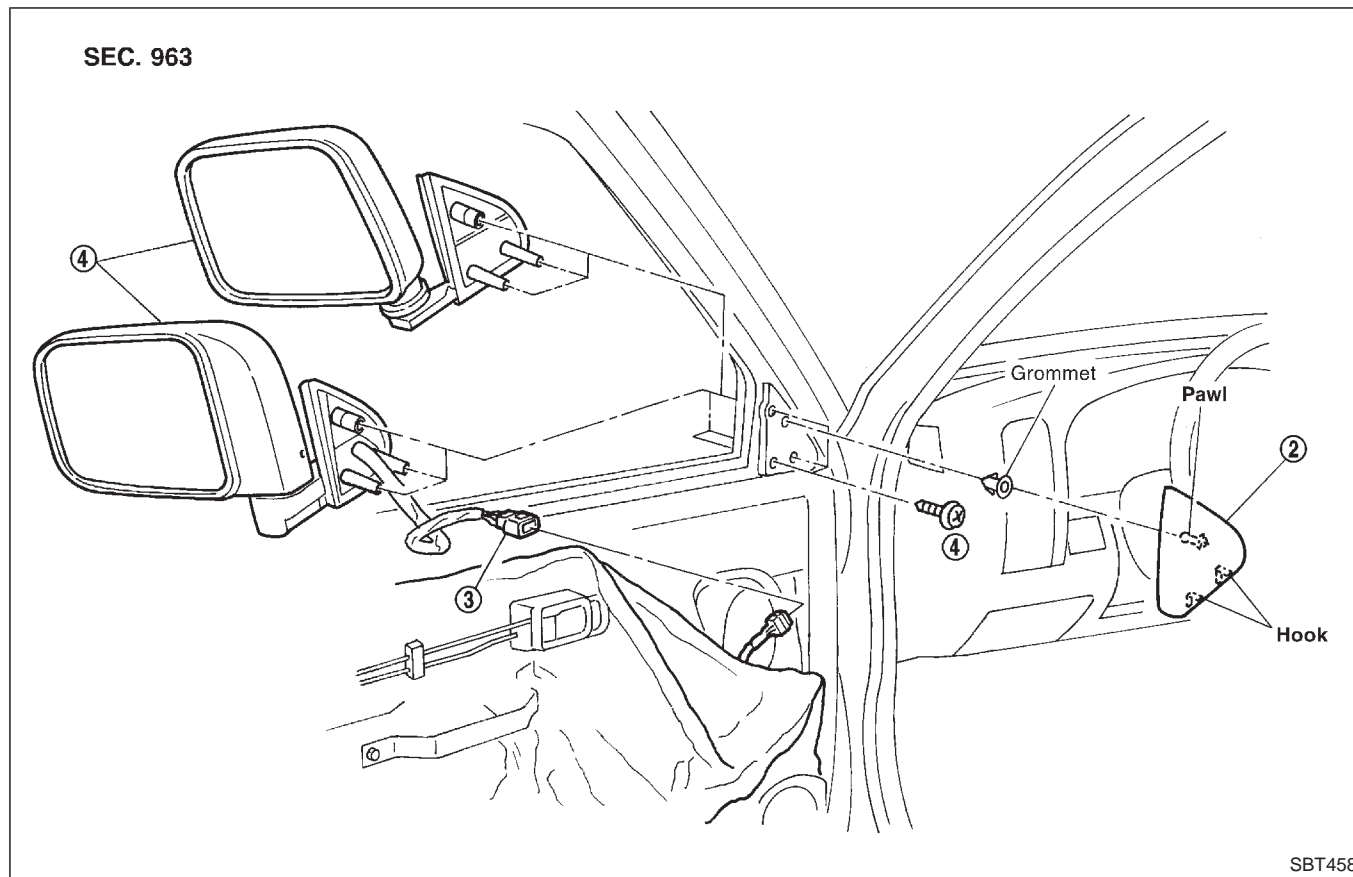

GI

MA

EM

LC

EC

FE

CL

MT

TF

PD

FA

RA

BR

ST

RS

BT

HA

EL

IDX

CAB AND REAR BODY

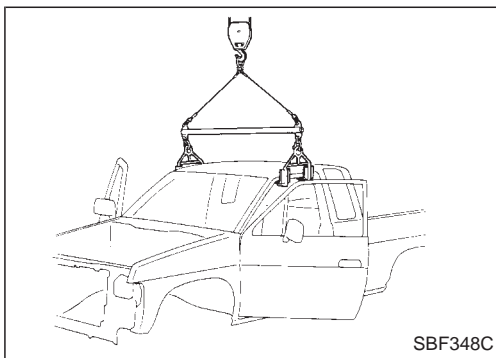

Removal

CAB BODY

- Remove the following parts in engine compartment at least.
 - (1) Main harness and other wiring harnesses
- Disconnect brake and clutch line in engine compartment.
- Remove the following parts from underbody at least.
 - (1) Transmission and transfer control levers
 - (2) Parking brake control lever and cables
 - (3) Main harness and other wiring harnesses

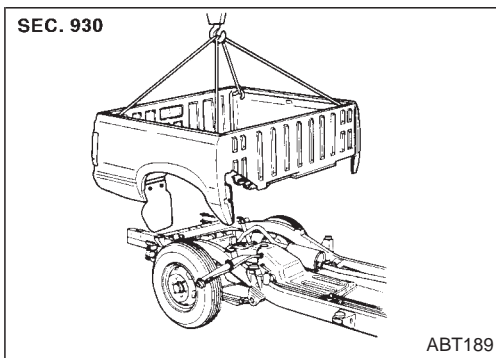

REAR BODY

- Remove the following parts at least.
 - (1) Rear combination lamp and license plate lamp harness
 - (2) Fuel filler tube fixing screws

CAB AND REAR BODY

Body Mounting

When removing, be sure to replace bolts and nuts (sealant applied bolts or self-lock nuts are used for all mounting).

SEC. 930

Single Cab model

Double Cab model

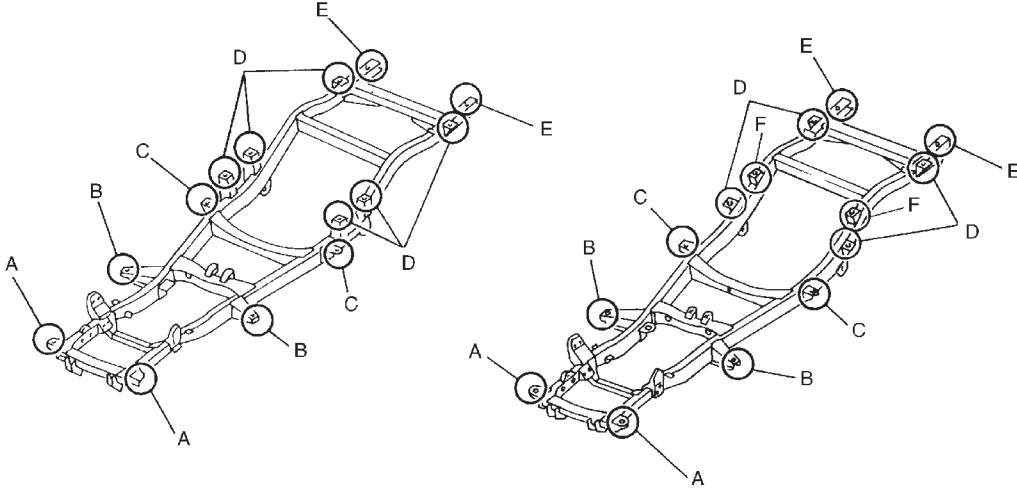

A

B

C

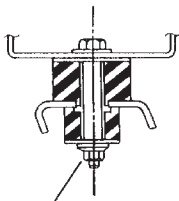

19 - 25
(1.9 - 2.6, 14 - 19)

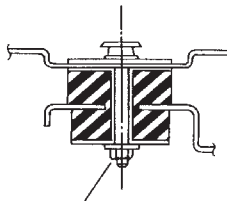

31 - 42
(3.2 - 4.3, 23 - 31)

31 - 42 (3.2 - 4.3, 23 - 31)

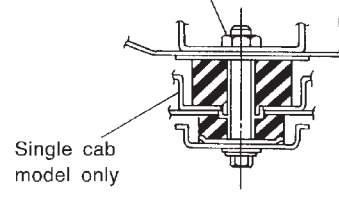

Single cab model only

D

E

F

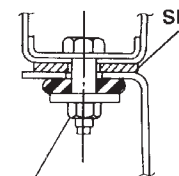

20 - 24
(2.0 - 2.4, 14 - 17)

Shim [t = 4.5 mm (0.177 in)]

Shim [t = 6.5 mm (0.256 in)]

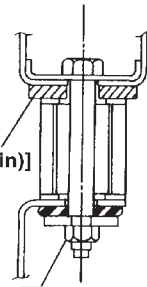

20 - 24
(2.0 - 2.4, 14 - 17)

Shim [t = 4.5 mm (0.177 in)]

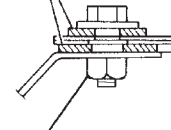

20 - 24
(2.0 - 2.4, 14 - 17)

: N·m (kg-m, ft-lb)

GI
MA
EM
LC
EC
FE
CL
MT
TF
PD
FA
RA
BR
ST
RS
BT
HA
EL
IDX

BODY ALIGNMENT

- All dimensions indicated in figures are actual ones.
- When using a tracking gauge, adjust both pointers to equal length. Make sure there is no free play.
- When a measuring tape is used, check to be sure there is no elongation, twisting or bending.
- Measurements should be taken at the center of the mounting holes.
- All measurements and mounting hole diameters are expressed in millimeters (mm).
- An asterisk (*) following the value at the measuring point indicates that the measuring point on the other side is symmetrically the same value.
- The coordinates of the measurement points are the distances measured from the respective dimension lines in the directions of "x", "y" and "z".

Dimension lines: "x" line — Center line of vehicle

"y" line — Center line of front axle (Any measurement point in front of the dimension line refers to a minus "-" value.)

"z" line — Datum line (Any measurement point under the dimension line refers to a minus "-" value.)

2W.SB : Short wheelbase (2WD)

2W.LB : Long wheelbase (2WD)

4W.LB : Long wheelbase (4WD)

BODY ALIGNMENT

Engine Compartment

MEASUREMENT

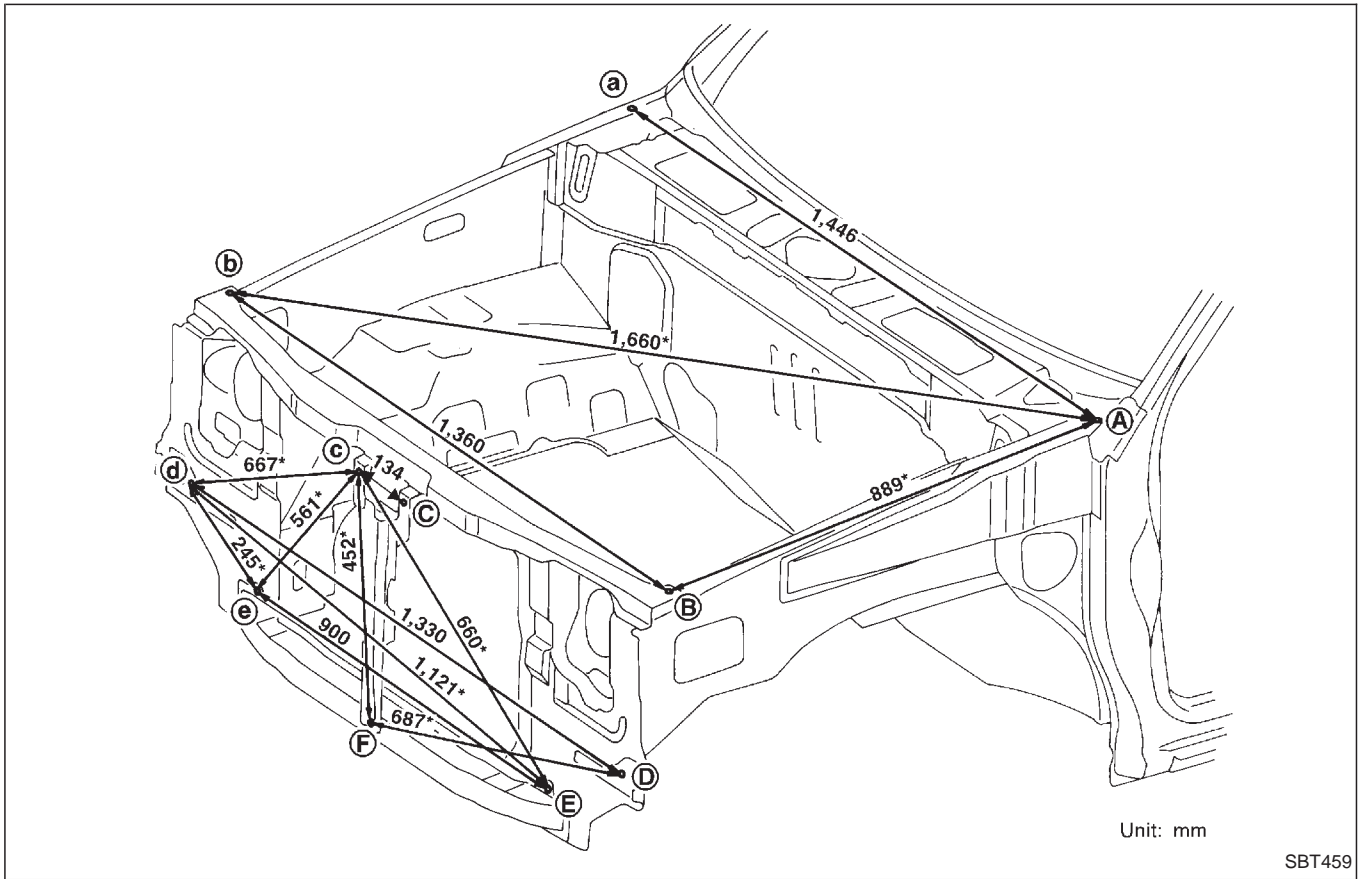

GI

MA

EM

LC

EC

FE

CL

MT

TF

PD

FA

RA

BR

ST

RS

BT

HA

EL

IDX

BODY ALIGNMENT

Engine Compartment (Cont'd)

MEASUREMENT POINTS

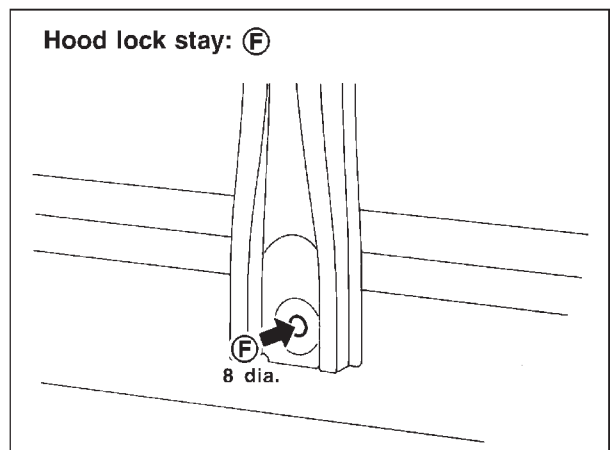
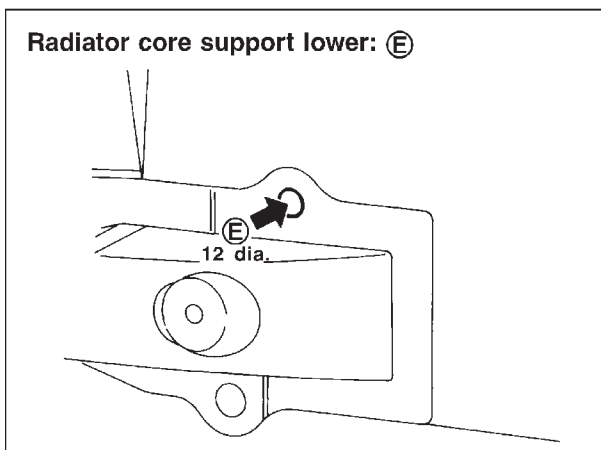
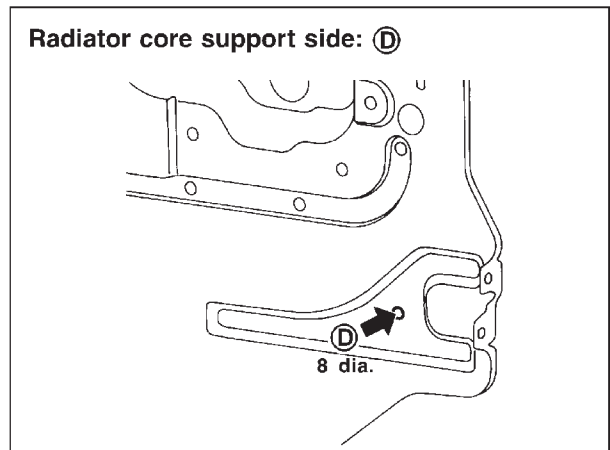
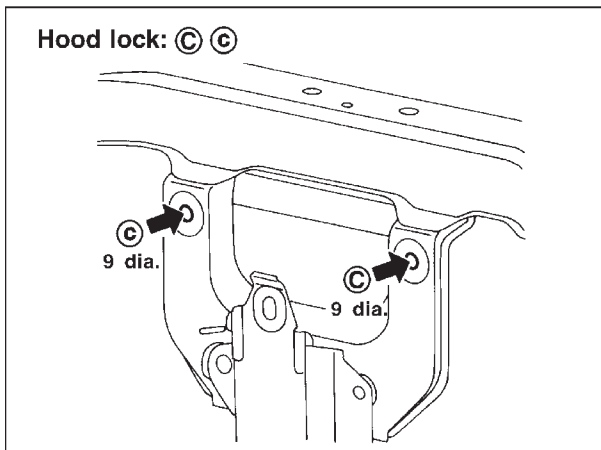
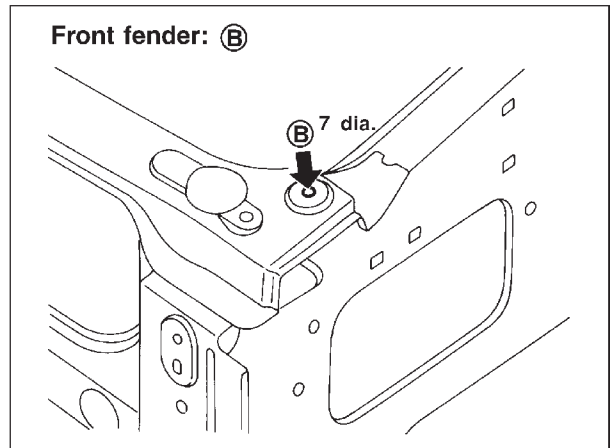
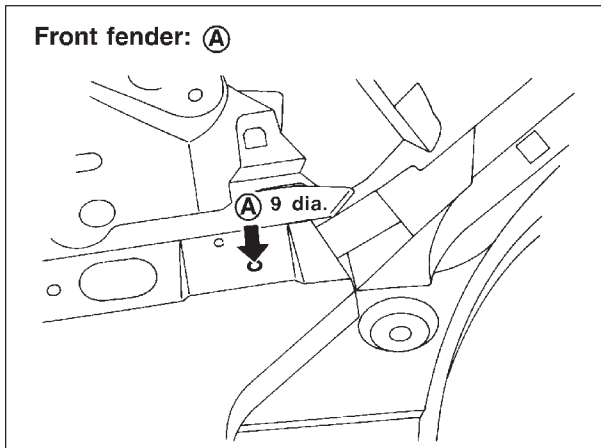

Unit: mm

BODY ALIGNMENT

Underbody

MEASUREMENT

2WD (Short wheelbase) models

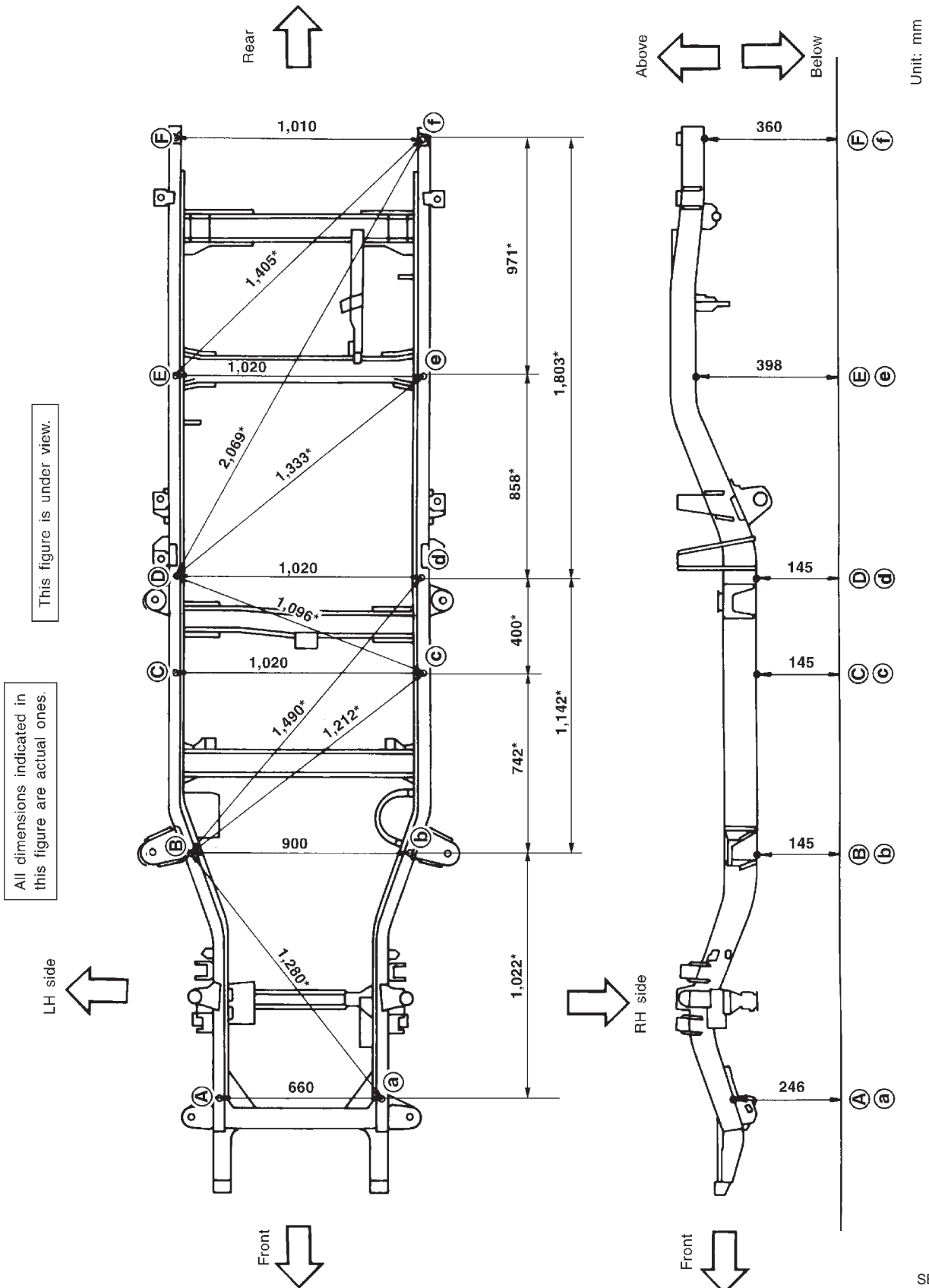

- GI
- MA
- EM
- LC
- EC
- FE
- CL
- MT
- TF
- PD
- FA
- RA
- BR
- ST
- RS
- BT**
- HA
- EL
- IDX

BODY ALIGNMENT

Underbody (Cont'd)

MEASUREMENT POINTS

2WD (Short wheelbase) models

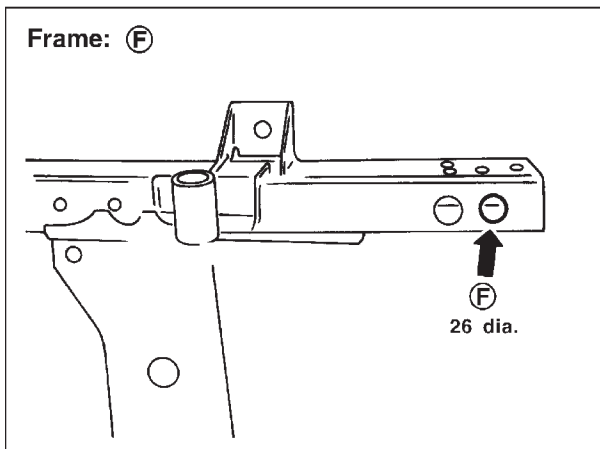
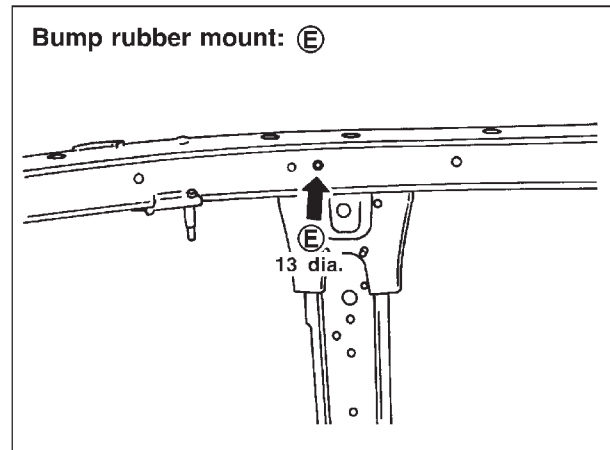
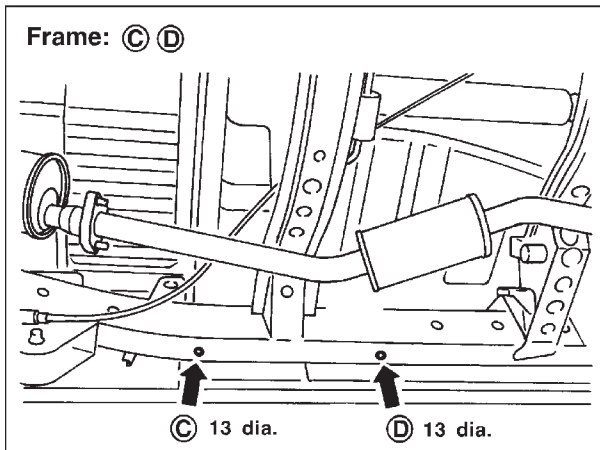
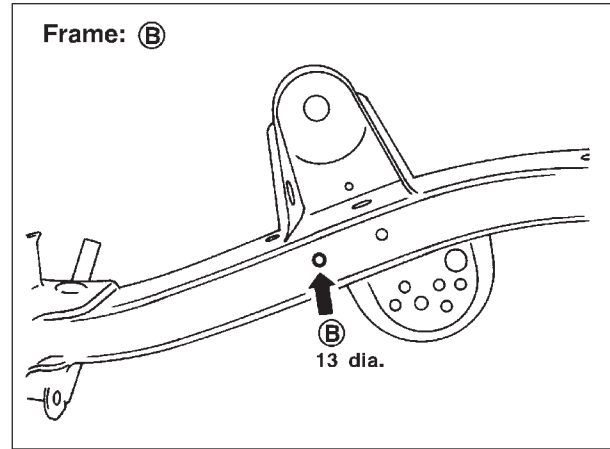
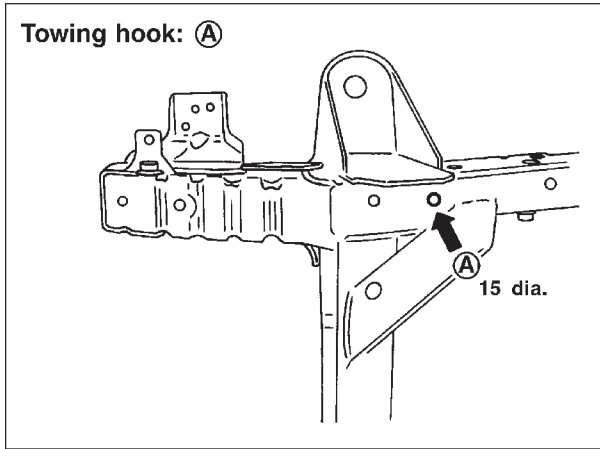

Coordinates:

(A) , (a)	(D) , (d)
X: 330	X: 510
Y: -409.7	Y: 1,740
Z: 246.2	Z: 145.1
(B) , (b)	(E) , (e)
X: 450	X: 510
Y: 600	Y: 2,560
Z: 145	Z: 398
(C) , (c)	(F) , (f)
X: 510	X: 505
Y: 1,340	Y: 3,530
Z: 145	Z: 360

Unit: mm

BODY ALIGNMENT

Underbody (Cont'd)

MEASUREMENT

2WD-4WD (Long wheelbase) models

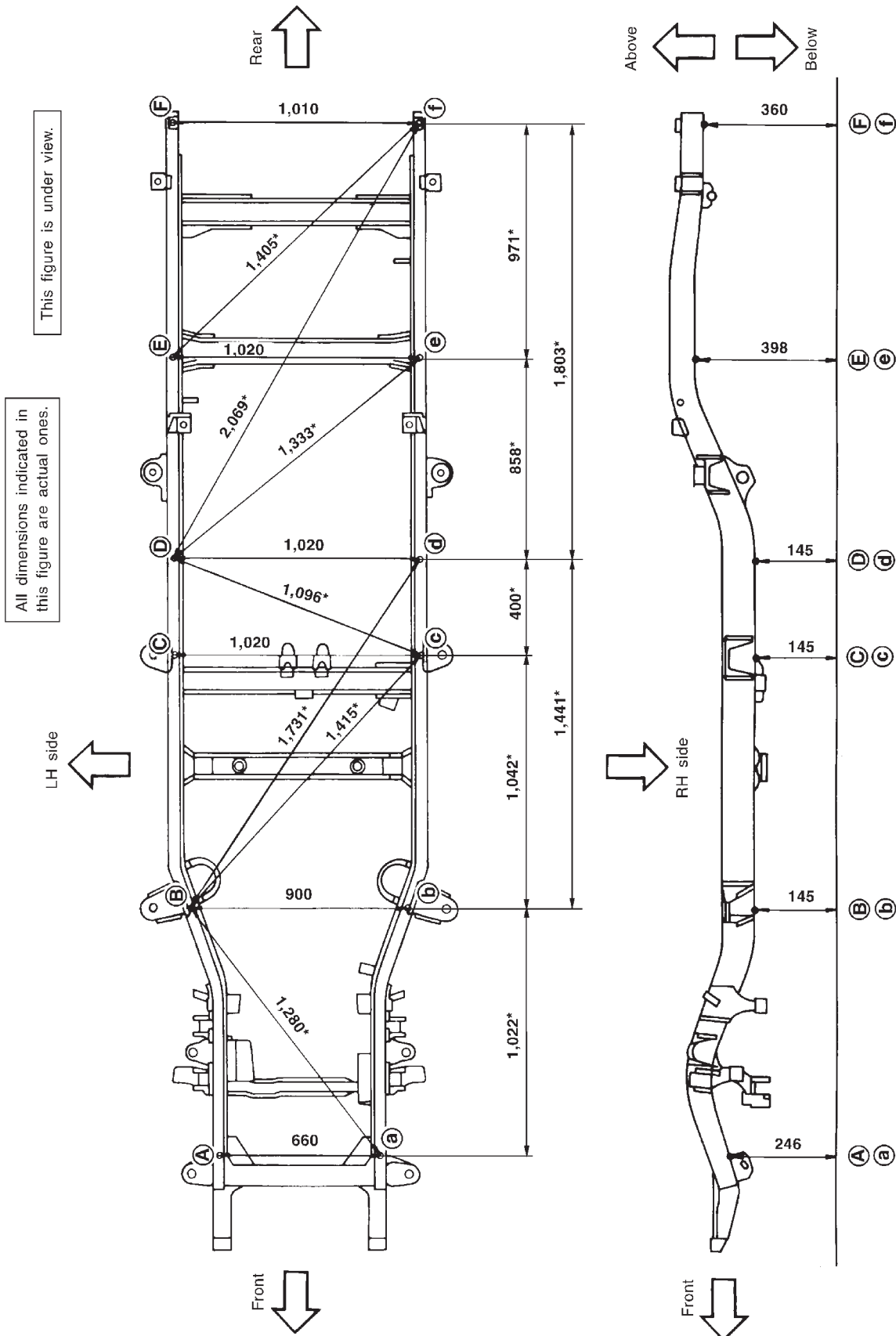

GI
MA
EM
LC
EC
FE
CL
MT
TF
PD
FA
RA
BR
ST
RS
BT
HA
EL
IDX

BODY ALIGNMENT

Underbody (Cont'd)

MEASUREMENT POINTS

2WD-4WD (Long wheelbase) models

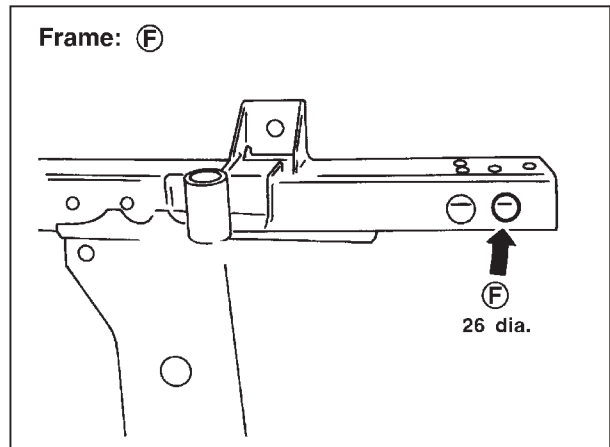
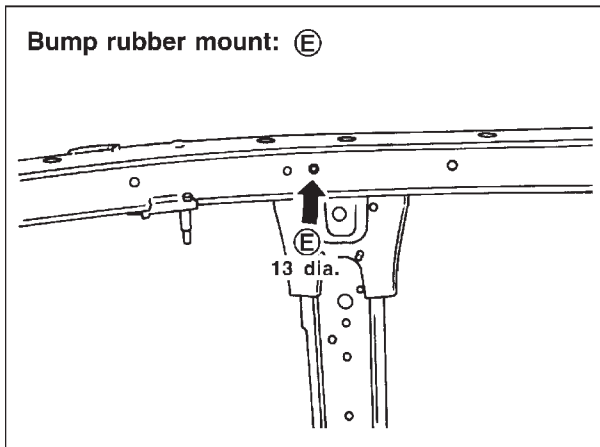
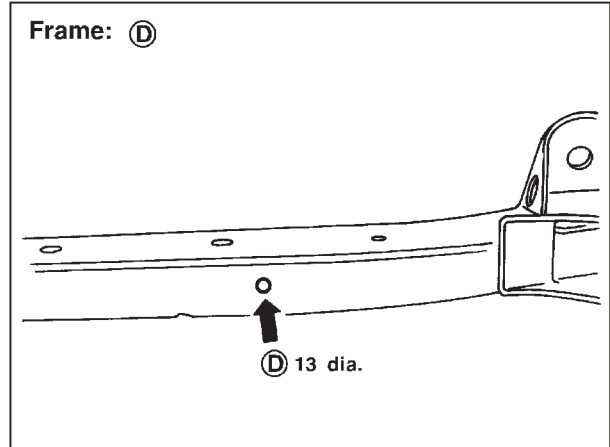
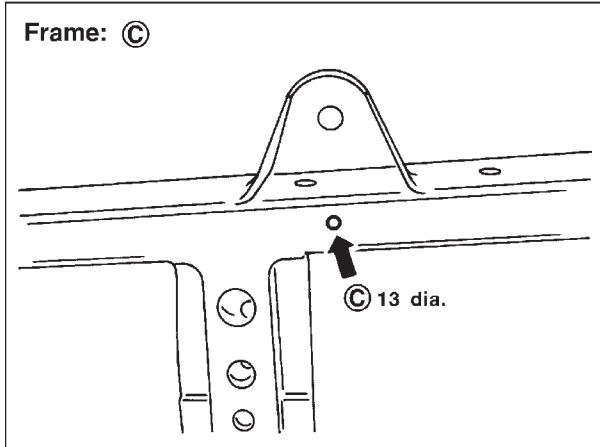
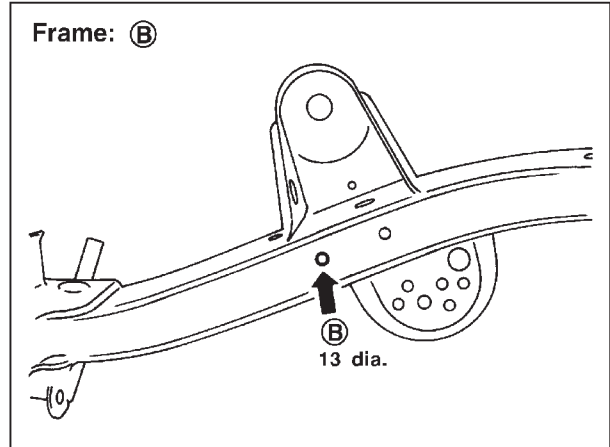
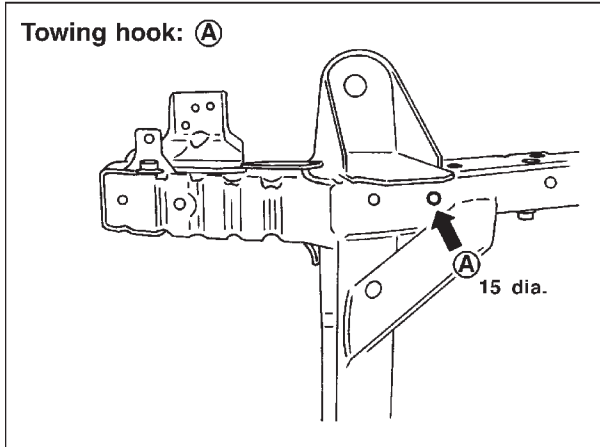

Unit: mm

Coordinates:

(A) , (a)	(B) , (b)	(C) , (c)	(D) , (d)	(E) , (e)	(F) , (f)
X: 330	X: 450	X: 510	X: 510	X: 510	X: 505
Y: -409.7	Y: 600	Y: 1,640	Y: 2,040	Y: 2,860	Y: 3,830
Z: 246.2	Z: 145	Z: 145	Z: 145.1	Z: 398	Z: 360

SBT464