

EM

SECTION

MODIFICATION NOTICE:

- Valve lifter of ZD30DDT engine has been changed from a type without shim to a type with adjusting shim. For information not included here, refer to information for ZD30DDT engines in NISSAN model D22 series SERVICE MANUAL Supplement-VIII 1st Revision (Publication No. SM3E-D22HG1).

CONTENTS

PREPARATION2
 Special Service Tools2

ZD

CAMSHAFT3
 Removal and Installation3
 Inspection.....4

VALVE CLEARANCE INSPECTIONS AND ADJUSTMENTS.....5

Adjustments5

CYLINDER HEAD.....8

Disassembly and Assembly.....8

SERVICE DATA AND SPECIFICATIONS (SDS)9

Valve9

PREPARATION

Special Service Tools

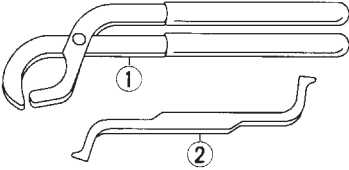
Tool number Tool name	Description
KV101151S0 Lifter stopper set ① KV10115110 Camshaft pliers ② KV10115120 Lifter stopper	 <p>Changing adjusting shims</p> <p>NT041</p>

Removal and Installation

SEC. 130

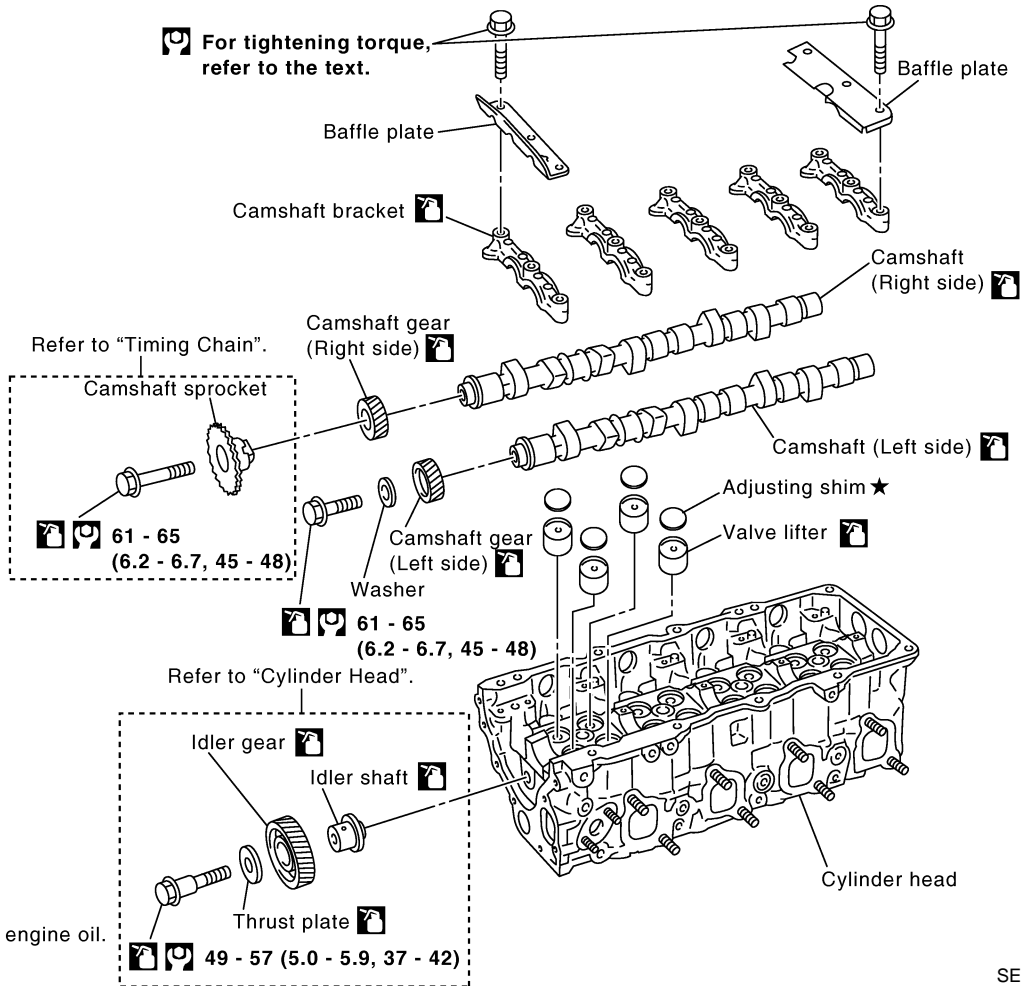

★ : Selective parts

: Lubricate with new engine oil.

: N·m (kg-m, ft-lb)

SEM203HA

GI
MA
EM
LC
EC
FE
CL
MT
AT
TF
PD
FA
RA
BR
ST
RS
BT
HA
EL
IDX

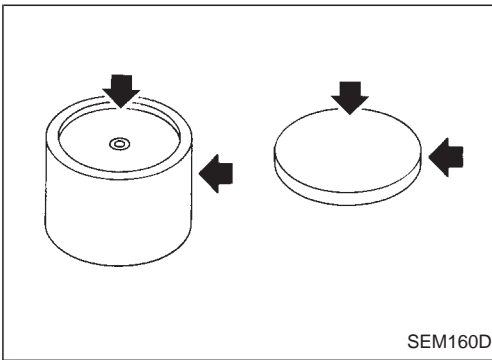

Inspection

VISUAL INSPECTION OF VALVE LIFTER AND ADJUSTING SHIM

- Check if surfaces of valve lifter and adjusting shim have any wear or cracks.
- Replace valve lifter or adjusting shim if necessary.
- Select the thickness of adjusting shim so that valve clearance is the standard when replacing. Refer to 5, "Adjustments".

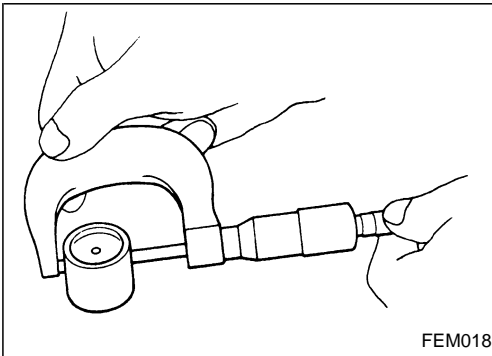

VALVE LIFTER OUTER DIAMETER

Measure the outer diameter of the valve lifter with a micrometer.

Standard: 34.450 - 34.465 mm (1.3563 - 1.3569 in)

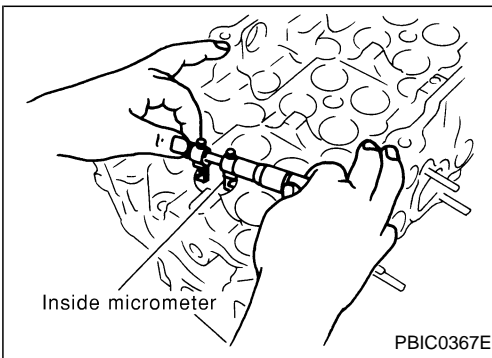

LIFTER GUIDE INNER DIAMETER

Measure the lifter guide inner diameter of the cylinder head with an inside micrometer.

Standard: 34.495 - 34.515 mm (1.3581 - 1.3589 in)

VALVE LIFTER CLEARANCE CALCULATIONS

Clearance = Lifter guide inner diameter – Valve lifter outer diameter

Standard: 0.030 - 0.065 mm (0.0012 - 0.0026 in)

If it exceeds the standard value, refer to the outer diameter and inner diameter standard values and replace valve lifter and/or cylinder head.

Adjustments

NOTE:

Adjust valve clearance while engine is cold.

- Remove the adjusting shim for parts which are outside the specified valve clearance.
1. Remove the spill tube. Refer to "BASIC SERVICE PROCEDURE" in EC section.

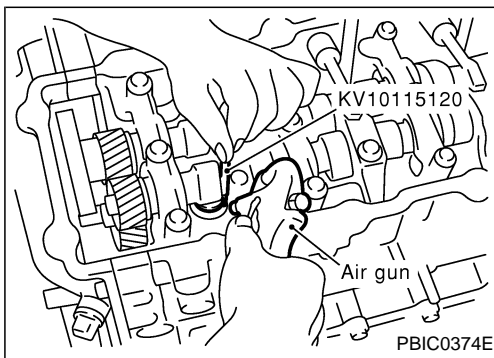
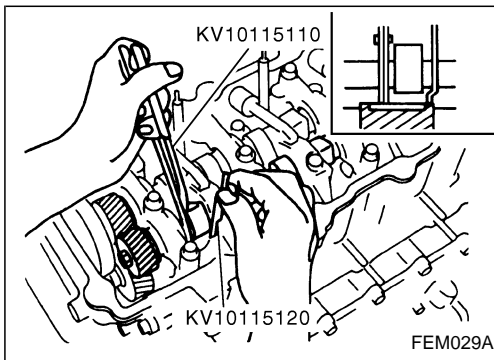
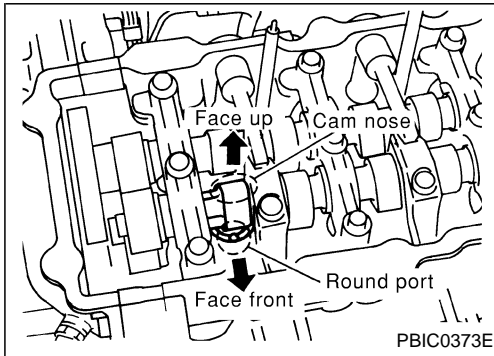

2. Rotate the crankshaft to face the cam nose for adjusting shims that are to be removed upward.
3. Thoroughly wipe off engine oil on the upper side of the cylinder head (for the air gun used in step 7).
4. Move the round hole of the adjusting shim to the front with an extra-fine screwdriver or like that.

CAUTION:

Perform (the above procedure) while camshaft do not contact with adjusting shim.

5. Grip the camshaft with camshaft pliers (SST), then using the camshaft as a support point, push the adjusting shim downward to compress the valve spring.

CAUTION:

Do not damage the camshaft, cylinder head, and the outer circumference of the valve lifter.

6. With the valve spring in a compressed state, remove the camshaft pliers (SST) by securely setting the outer circumference of the valve lifter with the end of the lifter stopper (SST).
 - Hold the lifter stopper by hand until the shim is removed.

CAUTION:

Do not retrieve the camshaft pliers forcefully, as the camshaft will be damaged.

7. Remove the adjusting shim from the valve lifter by blowing air through the round hole of the adjusting shim with an air gun.

CAUTION:

- When blowing, use goggles to protect your eye.
- To prevent any remaining oil from being blown around, thoroughly wipe the area clean.

GI

MA

EM

LC

EC

FE

CL

MT

AT

TF

PD

FA

RA

BR

ST

RS

BT

HA

EL

IDX

Adjustments (Cont'd)

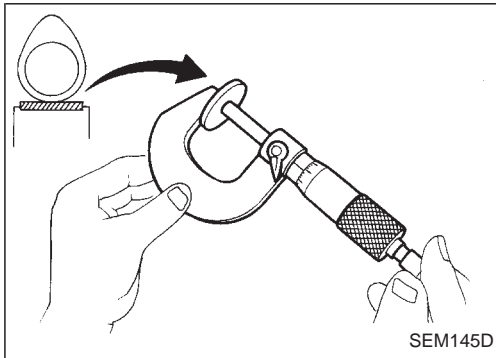
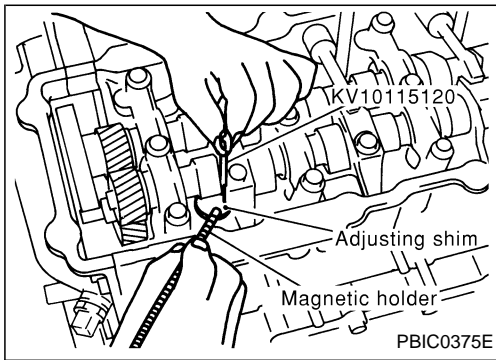

8. Remove the adjusting shim by using a magnetic holder.

9. Measure the thickness of the adjusting shim using a micrometer.

- Measure near the center of the shim (the part that touches the camshaft).

10. Select the new adjusting shim from the following methods.

Calculation method of the adjusting shim thickness:

$$t = t_1 + (C_1 - C_2)$$

t = Thickness of replacement adjusting shim

t₁ = Thickness of removed adjusting shim

C₁ = Measured valve clearance

C₂ = Specified valve clearance

When engine is cold [Approximately 20°C (68°F)]

0.35 mm (0.014 in)

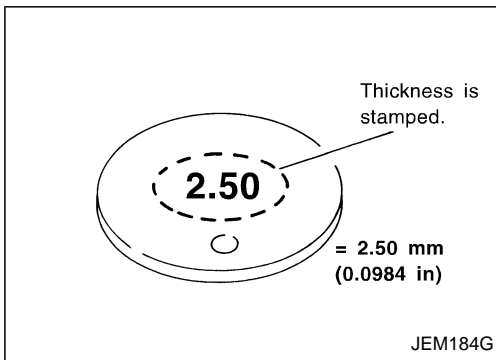

- New adjusting shims have the thickness stamped on the rear side.

Stamped	Shim thickness	mm (in)
2.35	2.35	(0.0925)
2.40	2.40	(0.0945)
.	.	.
.	.	.
3.05	3.05	(0.1201)

- The thickness of the adjusting shim ranges from 2.35 to 3.05 mm (0.0925 to 0.1201 in), where in the space of 0.05 mm (0.0020 in). There are 15 types of shims available.

11. Fit the selected adjusting shim to the valve lifter.

CAUTION:

Place the stamped side of the adjusting shim to the valve lifter.

Adjustments (Cont'd)

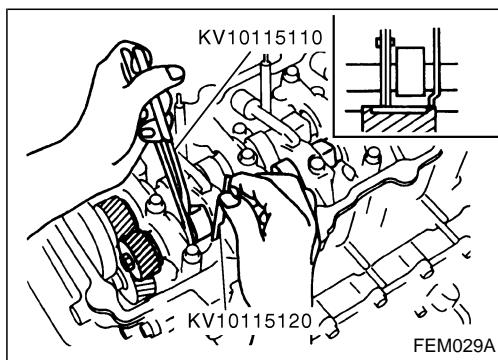

12. Compress the valve spring using the camshaft pliers (SST) and remove the lifter stopper (SST).

GI

MA

EM

LC

13. Rotate the crankshaft 2 to 3 times by hand.
 14. Confirm that the valve clearance is within the specification.

EC

Valve clearance:

When engine is cold [Approximately 20°C (68°F)]

Intake and exhaust

0.30 - 0.40 mm (0.012 - 0.016 in)

FE

15. Install remaining parts in the reverse order of removal.

CL

MT

AT

TF

PD

FA

RA

BR

ST

RS

BT

HA

EL

IDX

Disassembly and Assembly

SEC. 111•130

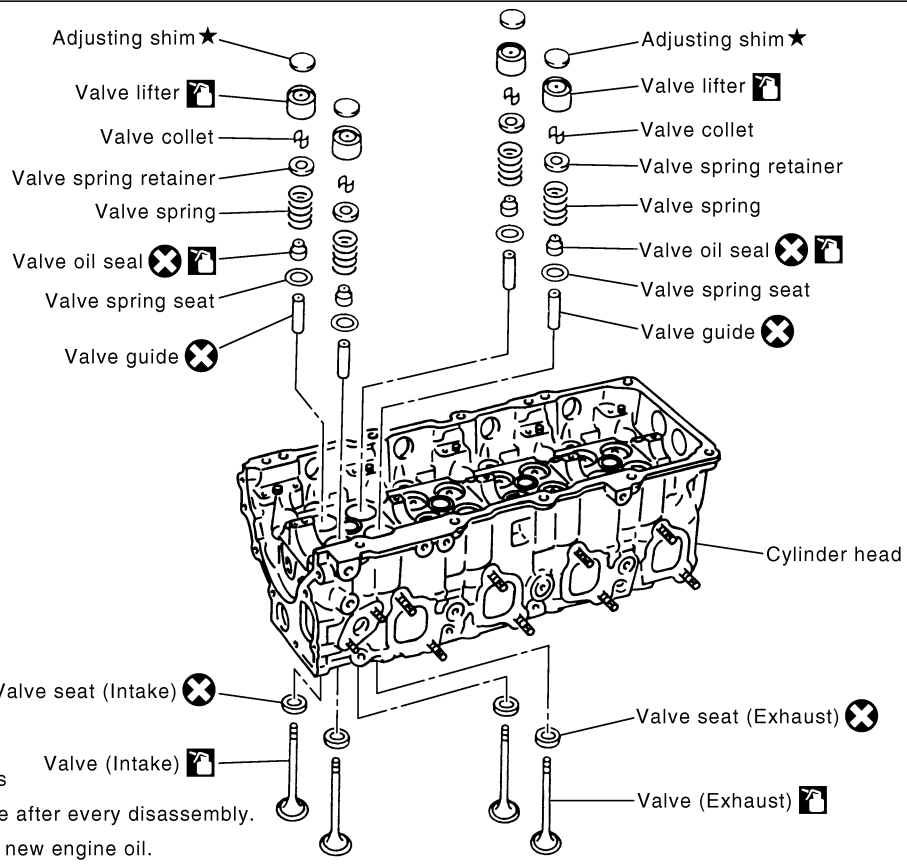

★ : Selective parts

[X] : Always replace after every disassembly.

[oil can icon] : Lubricate with new engine oil.

FEM081A

Valve

VALVE CLEARANCE

Unit: mm (in)

Items	Cold*
Intake and exhaust	0.30 - 0.40 (0.012 - 0.016)

*: Approximately 20°C (68°F)

AVAILABLE SHIMS

Thickness mm (in)	Identification mark
2.35 (0.0925)	2.35
2.40 (0.0945)	2.40
2.45 (0.0965)	2.45
2.50 (0.0984)	2.50
2.55 (0.1004)	2.55
2.60 (0.1024)	2.60
2.65 (0.1043)	2.65
2.70 (0.1063)	2.70
2.75 (0.1083)	2.75
2.80 (0.1102)	2.80
2.85 (0.1122)	2.85
2.90 (0.1142)	2.90
2.95 (0.1161)	2.95
3.00 (0.1181)	3.00
3.05 (0.1201)	3.05

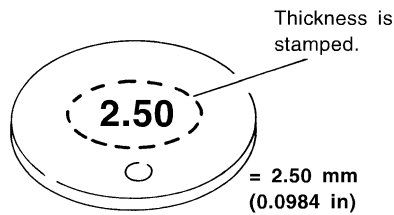

JEM184G

VALVE LIFTER

Unit: mm (in)

Valve lifter outer diameter	34.450 - 34.465 (1.3563 - 1.3569)
Lifter guide inner diameter	34.495 - 34.515 (1.3581 - 1.3589)
Clearance between lifter and lifter guide	0.030 - 0.065 (0.0012 - 0.0026)

GI
MA
EM
LC
EC
FE
CL
MT
AT
TF
PD
FA
RA
BR
ST
RS
BT
HA
EL
IDX