MODIFICATION NOTICE:

- Load suspension for single cab 2WD A-chassis has been terminated.
- Specification for double cab 4WD E-grade has been modified.
- Low-geared final drive has been added to the KA24DE equipped models for the Middle East.
- 265/70R16 size tire has been added as an option for Europe.

CONTENTS

CONSULT-II CHECKING SYSTEM2	IDENTIFICATION INFORMATION4
Function and System Application2	Model Variation4
Nickel Metal Hydride Battery Replacement.....2	Identification Number6
Checking Equipment.....3	Wheels and Tires.....9
CONSULT-II Data Link Connector (DLC) Circuit3	Dimensions10

This modification has been included in production starting with the following vehicle identification numbers (Chassis number):

For Australia and New Zealand

- JN1ADGD22A0040001 ●
- JN1ANUD22A0028001 ●
- JN1BNUD22A0030001 ●
- JN1CDGD22A0040001 ●
- JN1CRUD22A0020001 ●
- JN1CNUD22A0040001 ●
- JN1CPGD22A0012501 ●
- JN1APGD22A0020001 ●
- JN1BPGD22A0030001 ●

For the Middle East

- JN6DD23S*5A770101
- JN6HD23S*5A770101
- JN6DD23Y*5A770101
- JN6PD23S*5A770101
- JN6PD23Y*5A770101
- JN6DD23S*5A770001
- JN6DD21S*5X086001
- JN6DD22S*5X075001
- JN6DD23S*5X170001
- JN6DD22Y*5X028001
- JN6DD23Y*5X035001
- JN6HD21S*5X050001
- JN6HD23S*5X060001
- JN6PD23S*5X200001
- JN6PD23Y*5X300001

For Iraq and Libya

- JN1ADGD22Z0350001
- JN1CDGD22Z0350001
- JN1CDUD22Z0350001

For Europe

- JN1CPUD22U0820101 ●
- JN1APGD22U0070001 ●
- JN1APUD22U0050001 ●
- JN1BPGD22U0040001 ●
- JN1BPUD22U0120001 ●
- JN1CPGD22U0070001 ●
- JN1CPGD22U0770101 ●
- JN1CPUD22U0130001 ●
- JN1ADGD22U0030001 ●
- JN1BDGD22U0040001 ●
- JN1BDUD22U0040001 ●

For Israel

- JN1CPGD225A707101 ●
- JN1CPGD225A708101 ●
- JN1CPUD225A707101 ●
- JN1CPUD225A708101 ●
- JN1CPGD225X570201 ●
- JN1CPUD225X580401 ●

For Venezuela, Ecuador and Peru

- JN1CDGD225A713101 ●
- JN1CDUD225A713101 ●
- JN1CHGD225A713101 ●
- JN1CPGD225A790301 ●
- JN1CNUD225A713101 ●
- JN1ADGD225X430401 ●
- JN1ADUD225X430401 ●
- JN1APGD225X430001 ●
- JN1ANUD225X430501 ●

- JN1AHGD225X430301 ●
- JN1CDGD225X440501 ●
- JN1CPGD225X461101 ●
- JN1CDUD225X440701 ●
- JN1CNUD225X450501 ●
- JN1CHGD225X440301 ●

Except for Australia, New Zealand, the Middle East, Europe, Israel, Venezuela, Ecuador and Peru

- JN1ADGD22Z0033001 ●
- JN1AHGD22Z0035501 ●
- JN1APGD22Z0000301 ●
- JN1ADUD22Z0022501 ●
- JN1AJUD22Z0034001 ●
- JN1ANUD22Z0002301 ●
- JN1CDGD22Z0043301 ●
- JN1CHGD22Z0076701 ●
- JN1CPGD22Z0003601 ●
- JN1CDUD22Z0033001 ●
- JN1CJUD22Z0066001 ●
- JN1CNUD22Z0006001 ●

CONSULT-II CHECKING SYSTEM

Function and System Application

Diagnostic test mode	Function	ENGINE	A/T	ABS	AIR BAG
Work support	This mode enables a technician to adjust some devices faster and more accurate by following the indications on CONSULT-II.	x	x	—	—
Self-diagnostic results	Self-diagnostic results can be read and erased quickly.	x	x	x	x
Trouble diagnostic record	Current self-diagnostic results and all trouble diagnostic records previously stored can be read.	—	—	—	x
ECU discriminated No.	Classification number of a replacement ECU can be read to prevent an incorrect ECU from being installed.	—	—	—	x
Data monitor	Input/Output data in the ECU (ECM) can be read.	x	x	x	—
DTC work support	This mode enables a technician to set operating conditions to confirm self-diagnosis status/results.	—	x	—	—
Active test	Diagnostic Test Mode in which CONSULT-II drives some actuators apart from the ECMs and also shifts some parameters in a specified range.	x	—	x	—
ECU (ECM) part number	ECU (ECM) part number can be read.	x	x	x	—
Function test	Conducted by CONSULT-II instead of a technician to determine whether each system is "OK" or "NG" (No Good).	x	x	x	x

x: Applicable

Nickel Metal Hydride Battery Replacement

CONSULT-II contains a nickel metal hydride battery. When replacing the battery obey the following:

WARNING:

Replace the nickel metal hydride battery with Genuine CONSULT-II battery only. Use of another battery may present a risk of fire or explosion. The battery may present a fire or chemical burn hazard if mistreated. Do not recharge, disassemble or dispose of in fire.

Keep the battery out of reach of children and discard used battery conforming to the local regulations.

Checking Equipment

When ordering the below equipment, contact your NISSAN distributor.

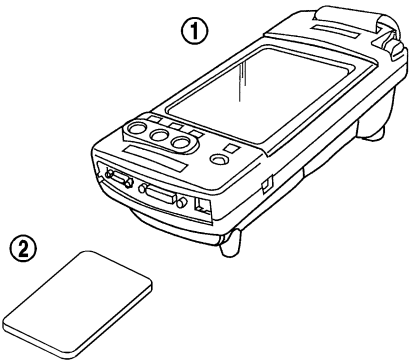
Tool name	Description
<p>NISSAN CONSULT-II</p> <p>① CONSULT-II unit (Tester internal soft: Resident version 3.3.0) and accessories</p> <p>② Program card AED01C for diagnostic, AEN00A/00B for NATS.</p> <p>To confirm the best combination of those softwares, refer to CONSULT-II Operation Manual.</p>	
	SGI083A

NOTE:

- The CONSULT-II must be used in conjunction with a program card. CONSULT-II does not require loading (Initialization) procedure.
- Be sure the CONSULT-II is turned off before installing or removing a program card.

CONSULT-II Data Link Connector (DLC) Circuit

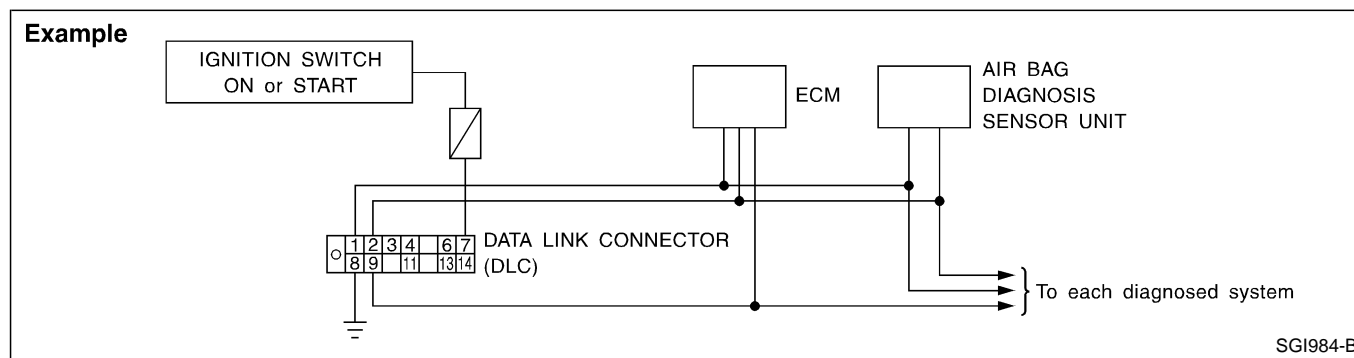

INSPECTION PROCEDURE

If the CONSULT-II cannot diagnose the system properly, check the following items.

Symptom	Check item
CONSULT-II cannot access any system.	<ul style="list-style-type: none"> ● CONSULT-II DLC power supply circuit (Terminal 7) and ground circuit (Terminal 8) (For detailed circuit, refer to "MIL & Data Link Connectors Wiring Diagram" in EC section.) ● CONSULT-II DDL cable
CONSULT-II cannot access individual system. (Other systems can be accessed.)	<ul style="list-style-type: none"> ● CONSULT-II program card (Check the appropriate CONSULT-II program card for the system. Refer to "Checking Equipment" above.) ● Power supply and ground circuit for the control unite of the system (For detailed circuit, refer to wiring diagram for each system.) ● Open or short circuit between the system and CONSULT-II DLC (For detailed circuit, refer to wiring diagram for each system.)

GI

MA

EM

LC

EC

FE

CL

MT

AT

TF

PD

FA

RA

BR

ST

RS

BT

HA

EL

IDX

IDENTIFICATION INFORMATION

Model Variation

PICKUP (2WD)

Destination	Class		Grade	Model		Engine	Transmission	Differential carrier	
	Cab	Wheelbase		LH drive	RH drive				
Australia and New Zealand	Single Cab	Long	DX	ABGGRDFD22EML	FS5W71C	KA24DE	C200		
				ABGGRDBD22EML					
	Double Cab			CBGGRDFD22EML	RE4R01A				
				CBGGRDBD22EML					
Europe	Single Cab	Long	STD	AVLGLCFD22UQL	FS5R30A	YD25DDTi	C200		
				ABGGLDFD22EQL					
	King Cab		DX	AVLGLDFD22UQL	FS5R30A				
				BBGGLDFD22EQN					
			4WD appearance	BVLGLDFD22UQN	FS5W71C				
				BVLGLDFD22UQJ					
				BVLGLDFD22UQG					
	Double Cab		DX	BVLGLEFD22UQJ	FS5R30A				
				BVLGLEFD22UQG					
	4WD appearance		ST	CVLGLDFD22UQN	FS5R30A				
				CVLGLDFD22UQJ					
	The Middle East		Single Cab	Short	DX	AVPALDFD22NKL	TD27	KA24DE	C200
						ABGALDFD22EKL			
Double Cab		ST	ABGALDFD22EKL		FS5W71C				
			ABGALDFD22EKL						
		STD	ABGGLCFD22EKL		FS5W71C				
			ABGGLCFD22EKL						
Double Cab		DX	CVPLDFD22NKL		RE4R01A				
			CBGGLDFD22EKL						
		ST	CBGGLDFD22EKL		FS5W71C				
			CBGGLDFD22EKL						
General areas (Except for the Middle East, Australia, New Zealand and Chile)		Single Cab	Long		SE	CBGGLFAD22EKL	KA24DE	YD25DDTi	C200
						CBGGLFAD22EKL			
	Single Cab	STD		AVLGLCFD22UWL	FS5W71C				
				ABGGLCFD22EWL					
		STD		AVPGLCFD22NWL	FS5W71C				
				CVLGLCFD22UWL					
				CBGGLCFD22EWL					
	Double Cab	STD		CVPLCFD22NWL	RE4R01A				
				CVPLCFD22NWL					
		SE		CBGGLFAD22EWN	FS5W71C				
				CVPLFFD22NWN					
4WD appearance	SE	CVLGLFFD22UWG	FS5W71C						
		CVLGLFFD22UWG							

IDENTIFICATION INFORMATION

Model Variation (Cont'd)

PICKUP (4WD)

Destination	Class		Grade	Model			Engine	Transmission	Differential carrier		Transfer					
	Cab	Wheelbase		LH drive	RH drive	Front			Rear							
Australia and New Zealand	Single Cab	Long	DX	—	—	AWSURDFD22TML	ZD30DDT	FS5R30A	R180	C200	TX10					
	King Cab		ST	—	—	BWSUREFD22TMN	VG33E									
	Double Cab		DX	—	—	CLPURDFD22EMN	ZD30DDT									
			ST	—	—	CWSURDFD22TMN	VG33E									
Europe	Single Cab	Long	STD	AVLULCFD22UQL	AVLURCFD22UQL	AVLURCFD22UQL	YD25DDTi	FS5R30A	R180	C200	TX10					
			DX	AVLULDFD22UQL	AVLURDFD22UQL	AVLURDFD22UQL	KA24DE	FS5W71C								
	King Cab		DX	BGGULDFD22EQN	—	—	BVLURDFD22UQN	YD25DDTi				FS5R30A				
			ST	BVLULEFD22UQN	BVLURDFD22UQN	BVLURDFD22UQN	YD25DDTi									
	Double Cab		DX	CVLULDFD22UQN	CVLURDFD22UQN	CVLURDFD22UQN	YD25DDTi									
			ST	CVLULEFD22UQN	CVLURDFD22UQN	CVLURDFD22UQN	YD25DDTi									
	Double Cab		SS	CVLULGFD22UQN	CVLURGFD22UQN	CVLURGFD22UQN	YD25DDTi									
			DX	ABGULDFD22EKL	—	—	KA24DE	FS5W71C								
	The Middle East		Single Cab	Long	DX	ABGULDFD22EKL	—	—				KA24DE	FS5W71C	R180	C200	TX10
			Double Cab		CBGULDFD22EKN	—	—	KA24DE				FS5W71C				
General areas (Except for the Middle East, Australia, New Zealand and Chile)	Single Cab	Long	STD	ABGULCFD22EWL	ABGURCFD22EWL	ABGURCFD22EWL	KA24DE	FS5W71C	R180	C200	TX10					
				AWLULCFD22TWL	AWLURCFD22TWL	AWLURCFD22TWL	ZD30DDT	FS5R30A								
	AVRULCFD22NWL		AVRURCFD22NWL	AVRURCFD22NWL	QD32	FS5R30A										
	CBGULCFD22EWN		CBGURCFD22EWN	CBGURCFD22EWN	KA24DE	FS5W71C										
	CWSULCFD22TWN		CWSURCFD22TWN	CWSURCFD22TWN	ZD30DDT	FS5R30A										
	CVRULCFD22NWN		CVRURCFD22NWN	CVRURCFD22NWN	QD32	FS5R30A										
	CVRULCAD22NWL		—	—	RE4R01A	FS5W71C										
	CBGULFFD22EWN		—	—	KA24DE	FS5W71C										
	CWSULFFD22TWN		CWSURFFD22TWN	CWSURFFD22TWN	ZD30DDT	FS5R30A										
	CVRULFFD22NWN		CVRURFFD22NWN	CVRURFFD22NWN	QD32	FS5R30A										
Double Cab	SE	CVRULFAD22NWN	—	—	RE4R01A											

IDENTIFICATION INFORMATION

Model Variation (Cont'd)

Prefix and suffix designations (Pickup)

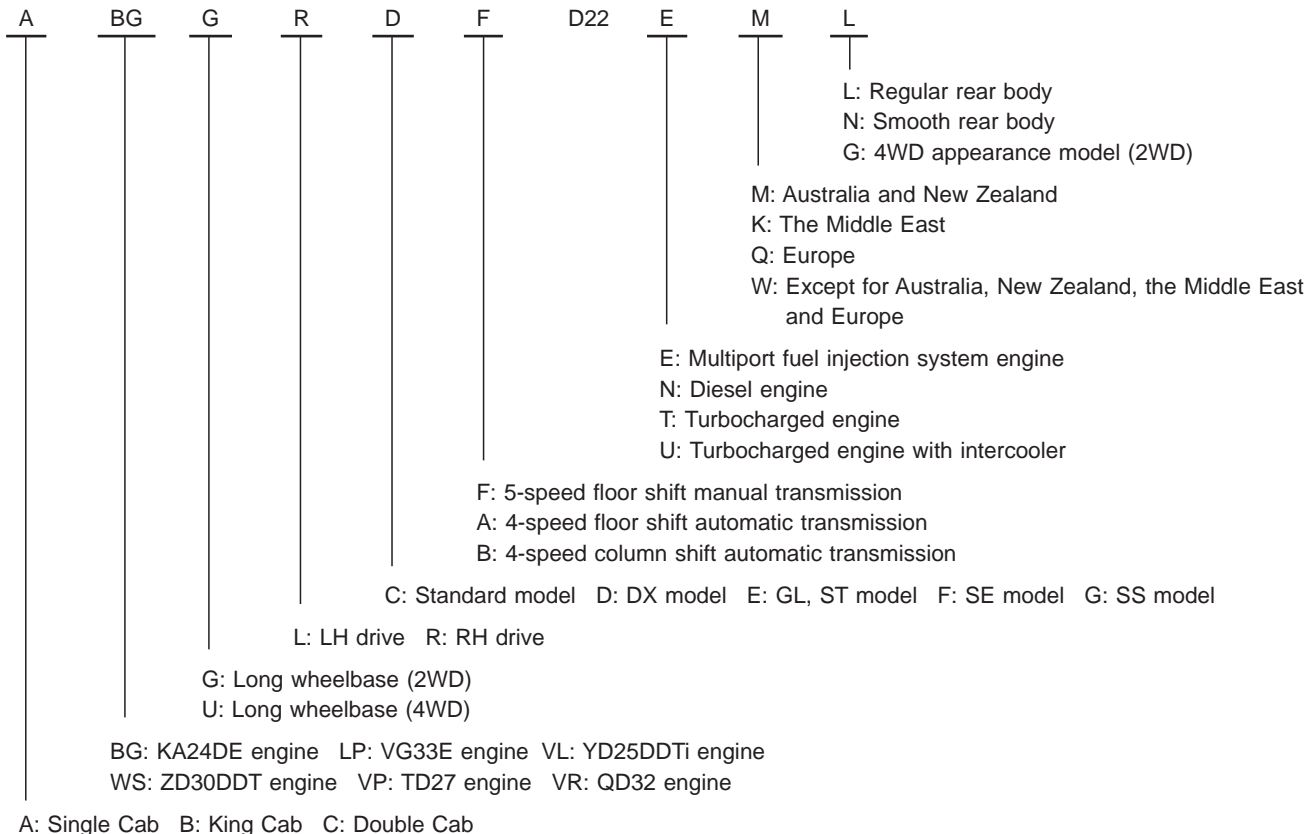

Identification Number

VEHICLE IDENTIFICATION NUMBER

Prefix and suffix designations

For Australia and New Zealand

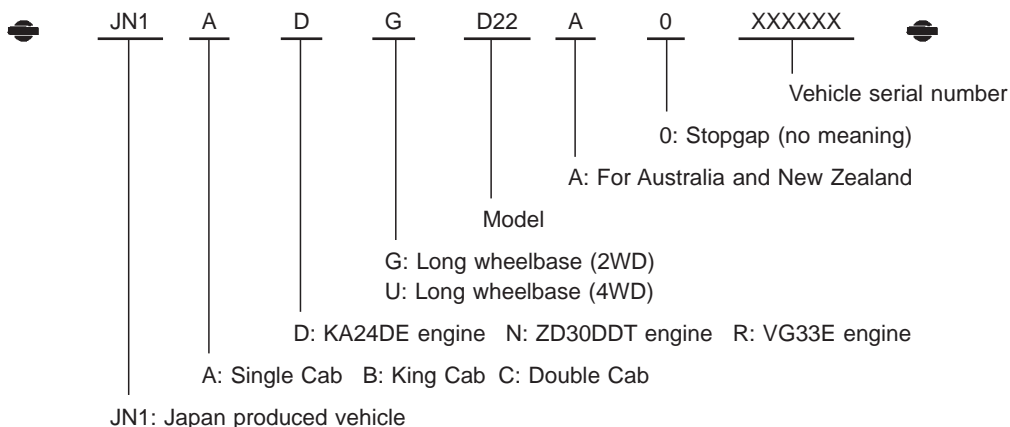

IDENTIFICATION INFORMATION

Identification Number (Cont'd)

For Israel

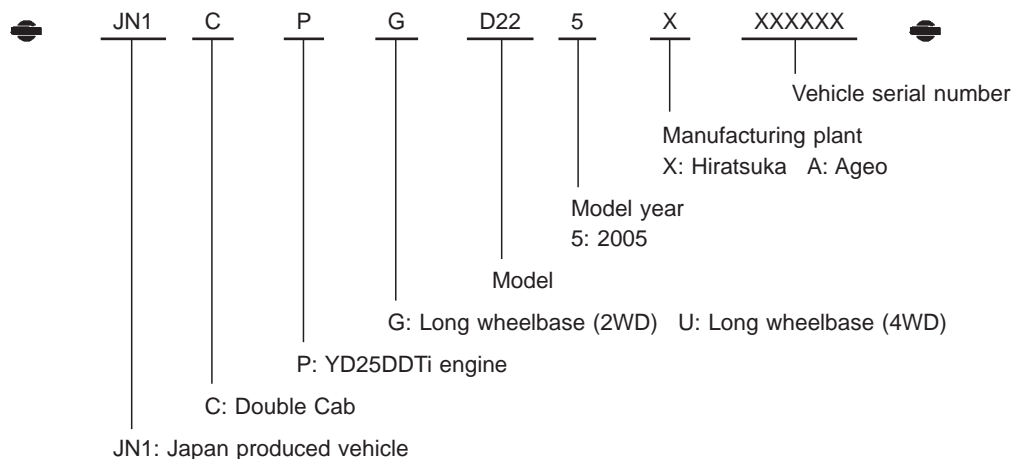

For Europe

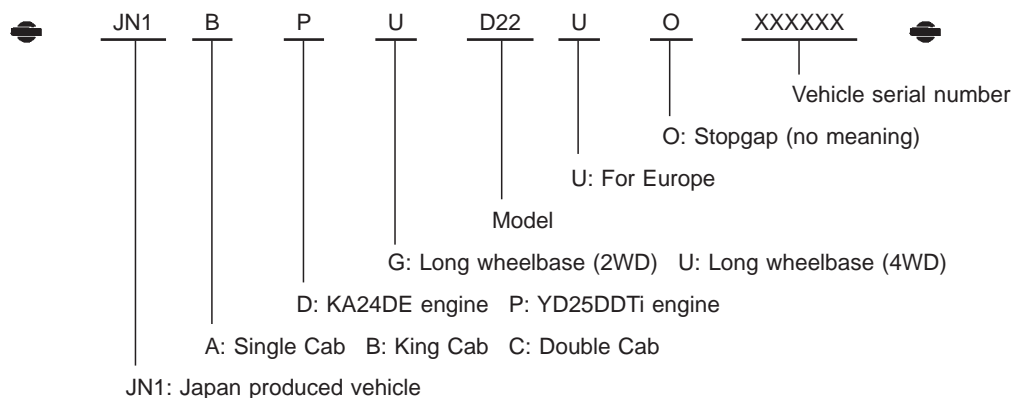

For the Middle East

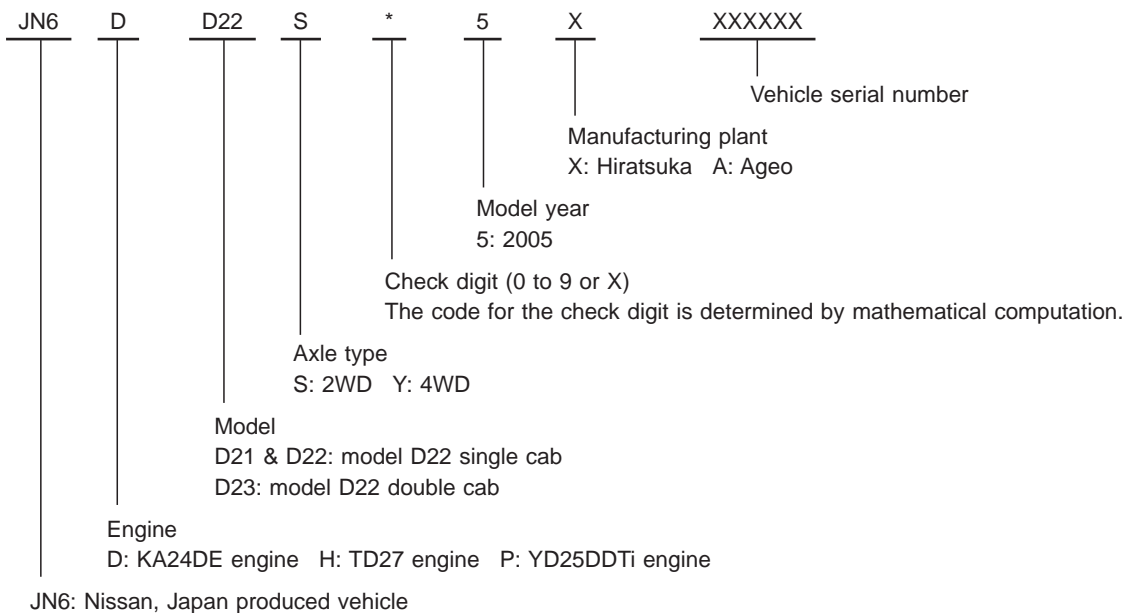

GI

MA

EM

LC

EC

FE

CL

MT

AT

TF

PD

FA

RA

BR

ST

RS

BT

HA

EL

IDX

IDENTIFICATION INFORMATION

Identification Number (Cont'd)

For Iraq and Libya

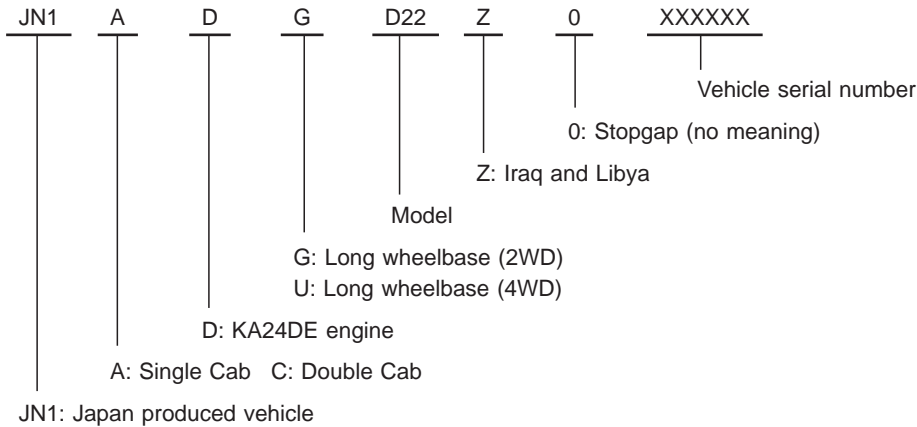

For Venezuela, Ecuador and Peru

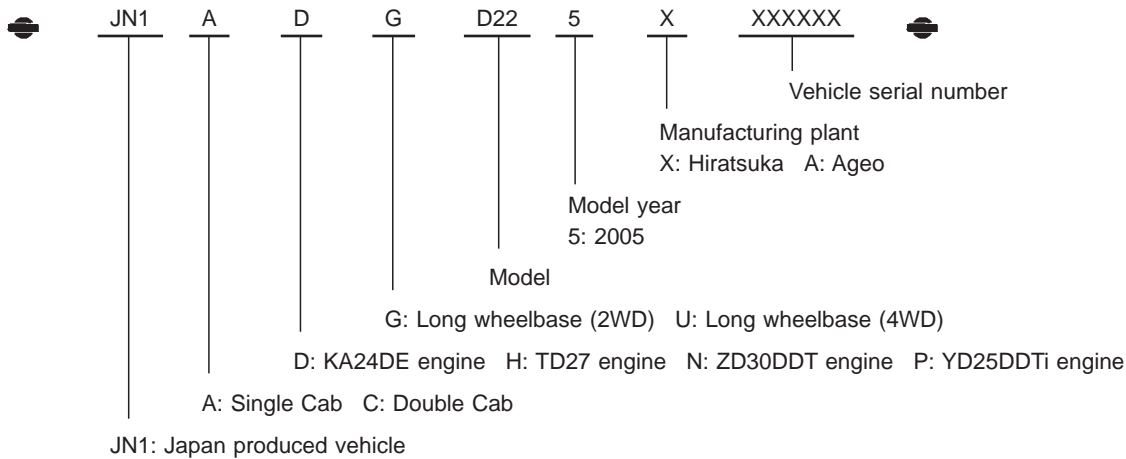

Except for Australia, New Zealand, the Middle East, Iraq, Libya, Europe, Israel, Venezuela, Ecuador and Peru

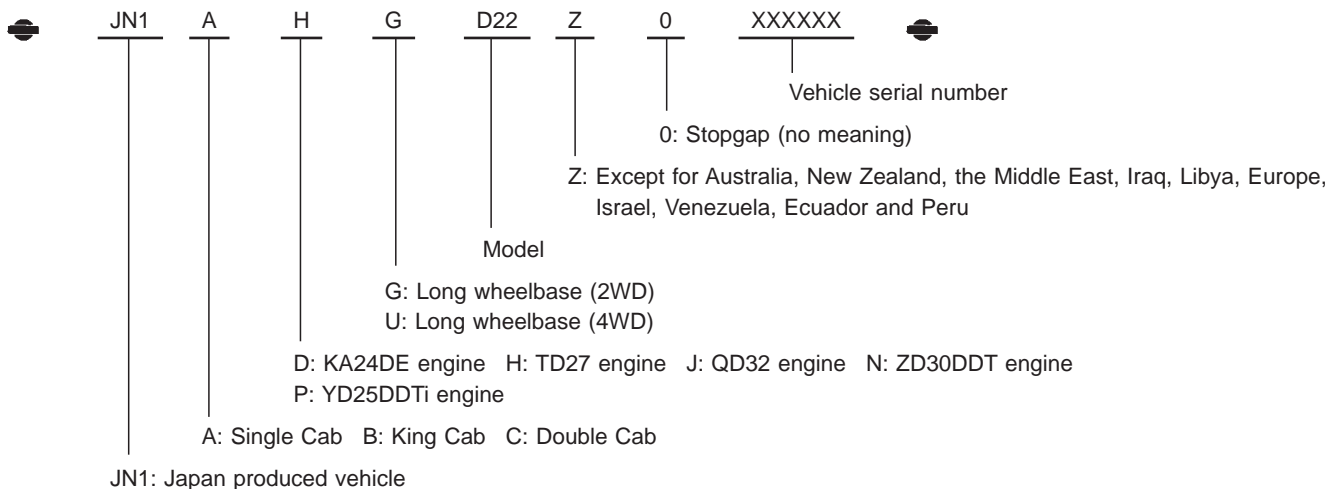

IDENTIFICATION INFORMATION

Wheels and Tires

PICKUP (2WD)

Model		2-wheel drive model							
		Except Australia, New Zealand and Europe		Australia and New Zealand			Europe		
		Single cab	Double cab	Single cab	King cab	Double cab	Single cab	King cab	Double cab
Tire	Wheel								
6.00/6.50-14-6/8PRLT*1	5J-14	X	X	—	—	—	—	—	—
6.50-14-8/8PRLT	5J-14	X	X	—	—	—	—	—	—
185R14C-8PR	5J-14	X	X	—	—	—	—	—	—
195R14-8PRLT	5J-14	—	—	X	X	X	—	—	—
195R14C-8PR	5J-14	X	X	—	—	—	X	X	X
195R15-8PRLT	5-1/2K-15	X	X	—	—	—	—	—	—
195R15C-8PR	5-1/2K-15	X	X	—	—	—	X	X	X
255/70R16	7JJ-16	—	X*2	—	—	—	—	X*2	X*2
265/70R16	7JJ-16	—	—	—	—	—	—	X*2	X*2

X: Applicable

—: Not applicable

*1: 6.00-14-6 for front/6.50-14-8 for rear

6-ply rating for front/8-ply rating for rear

*2: 4WD appearance models

PICKUP (4WD)

Model		4-wheel drive model		
		Except Australia, New Zealand and Europe	Australia and New Zealand	Europe
Tire	Wheel			
6.50-15-6/8PRLT*	5-1/2K-15	X	—	—
215R15-8PRLT	5-1/2K-15	X	—	—
215R15C-8PR	5-1/2K-15	X	—	—
205R16C-8PR	6J-16	X	X	X
255/70R16	7JJ-16	X	X	X
265/70R16	7JJ-16	X	X	X
255/60R17	8JJ-17	—	—	X

X: Applicable

—: Not applicable

*: 6-ply rating for front/8-ply rating for rear

GI

MA

EM

LC

EC

FE

CL

MT

AT

TF

PD

FA

RA

BR

ST

RS

BT

HA

EL

IDX

IDENTIFICATION INFORMATION

Dimensions

Destination		Except Australia, New Zealand and Europe				
Item	Vehicle type	2-wheel drive model			4-wheel drive model	
	Wheelbase	Long			Long	
	Cab or bed type	Single cab	Double cab		Single cab	Double cab
				4WD appearance		
Overall length*1	mm (in)	5,010 (197.2) 5,170 (203.5)*1	4,920 (193.7) 5,080 (200.0)*1 4,955 (195.1)*9 5,090 (200.4)*1, *9	4,945 (194.7) 5,080 (200.0)*1	5,010 (197.2) 5,170 (203.5)*1	4,945 (194.7) 5,080 (200.0)*1 4,955 (195.1)*9 5,090 (200.4)*1, *9
Overall width	mm (in)	1,690 (66.5)	1,690 (66.5)	1,825 (71.9)	1,825 (71.9)	1,825 (71.9)
Overall height	mm (in)	1,630 (64.2)*6 1,620 (63.8)*5 1,610 (63.4)*4	1,620 (63.8)*4 or *5 (*9) 1,630 (64.2)*5 or *6 (*9) 1,640 (64.6)*6	1,710 (67.3)*2	1,695 (66.7)*2 1,700 (66.9)*8	1,710 (67.3)*7 1,715 (67.5)*8 1,720 (67.7)*2 1,725 (67.9)*10 1,810 (71.3)*3, *7 1,815 (71.5)*3, *8 1,820 (71.7)*2, *3, *9 1,825 (71.9)*3, *10
Wheelbase	mm (in)	2,950 (116.1)	2,950 (116.1)	2,950 (116.1)	2,950 (116.1)	2,950 (116.1)
Tread	Front mm (in)	1,395 (54.9)	1,395 (54.9)	1,525 (60.0)	1,525 (60.0)	1,525 (60.0)
	Rear mm (in)	1,390 (54.7)	1,390 (54.7)	1,505 (59.3)	1,505 (59.3)	1,505 (59.3)
Ground clearance	mm (in)	170 (6.7)*4 180 (7.1)*5 190 (7.5)*6	170 (6.7)*4 180 (7.1)*5 190 (7.5)*6	240 (9.4)*2	225 (8.7)*7 230 (9.1)*8	225 (8.7)*7 230 (9.1)*8 240 (9.4)*2

*1: On step bumper equipped models

*2: 255/70R16 tire equipped models

*3: Roof rail equipped models

*4: 185R14 tire equipped models

*5: 195R14 tire equipped models

*6: 195R15 tire equipped models

*7: 215R15 tire equipped models

*8: 205R16 tire equipped models

*9: For Chili

*10: 265/70R16 tire equipped model

IDENTIFICATION INFORMATION

Dimensions (Cont'd)

Destination		Australia and New Zealand					
Item	Vehicle type	2-wheel drive model			4-wheel drive model		
	Wheelbase	Long			Long		
	Cab or bed type	Single cab	King cab	Double cab	Single cab	King cab	Double cab
Overall length*1	mm (in)	5,010 (197.2) 4,795 (188.8)*2	5,045 (198.6)*3	4,920 (193.7) 5,080 (200.0)*1	5,010 (197.2) 4,795 (188.8)*4	5,045 (198.6)	4,945 (194.7) 5,080 (200.0)*1
Overall width	mm (in)	1,690 (66.5)	1,690 (66.5)	1,690 (66.5)	1,825 (71.9)	1,825 (71.9)	1,825 (71.9)
Overall height	mm (in)	1,610 (63.4)	1,610 (63.4)*3	1,625 (64.0)	1,705 (67.1)*3 1,710 (67.3)*4	1,700 (66.9)	1,715 (67.5)*3 1,720 (67.7)*4 1,725 (67.9)*7 1,815 (71.3)*6, *3 1,820 (71.7)*6, *4 1,825 (71.9)*6, *7
Wheelbase	mm (in)	2,950 (116.1)	2,950 (116.1)	2,950 (116.1)	2,950 (116.1)	2,950 (116.1)	2,950 (116.1)
Tread	Front mm (in)	1,395 (54.9)	1,395 (54.9)	1,395 (54.9)	1,525 (60.0)	1,525 (60.0)	1,525 (60.0)
	Rear mm (in)	1,390 (54.7)	1,390 (54.7)	1,390 (54.7)	1,505 (59.3)	1,505 (59.3)	1,505 (59.3)
Ground clearance	mm (in)	155 (6.1)	155 (6.1)	160 (6.3)	220 (8.7)*3 225 (8.9)*4	220 (8.7)	220 (8.7) 225 (8.9)*7 205 (8.1)*5 210 (8.3)*5, *7

- *1: On step bumper equipped models
- *2: Cab and chassis models
- *3: 205R16 tire equipped models
- *4: 255/70R16 tire equipped models
- *5: VG33E engine models
- *6: Roof rail equipped models
- *7: 265/70R16 tire equipped models

GI

MA

EM

LC

EC

FE

CL

MT

AT

TF

PD

FA

RA

BR

ST

RS

BT

HA

EL

IDX

IDENTIFICATION INFORMATION

Dimensions (Cont'd)

Destination		Europe					
Vehicle type		2-wheel drive model			4-wheel drive model		
Wheelbase		Long			Long		
Cab or bed type		Single cab	King cab	Double cab	Single cab	King cab	Double cab
Overall length*1	mm (in)	5,020 (197.6)	5,045 (198.6)	4,955 (195.1)	5,020 (197.6)	5,045 (198.6)	4,955 (195.1)
		5,180 (203.9)*1	5,180 (203.9)*1	5,090 (200.4)*1	5,180 (203.9)*1	5,180 (203.9)*1	5,090 (200.4)*1
Overall width	mm (in)	1,690 (66.5)	1,690 (66.5)	1,690 (66.5)	1,825 (71.9)	1,825 (71.9)	1,825 (71.9)
			1,825 (71.9)*2	1,825 (71.9)*2			
Overall height	mm (in)	1,610 (63.4)	1,610 (63.4)	1,620 (63.8)	1,700 (66.9)	1,700 (66.9)	1,715 (67.5)
		1,620 (63.8)*4	1,700 (66.9)*2	1,630 (64.2)*4		1,705 (67.1)*3	1,815 (71.5)*6
			1,620 (63.8)*4	1,710 (67.3)*2		1,695 (66.7)*5	1,720 (67.7)*3
			1,810 (71.3)*2,*6				1,820 (71.7)*6,*3
							1,710 (67.3)*5
							1,810 (71.3)*6,*5
Wheelbase	mm (in)	2,950 (116.1)	2,950 (116.1)	2,950 (116.1)	2,950 (116.1)	2,950 (116.1)	2,950 (116.1)
Tread	Front mm (in)	1,395 (54.9)	1,395 (54.9)	1,395 (54.9)	1,525 (60.0)	1,525 (60.0)	1,525 (60.0)
	Rear mm (in)	1,390 (54.7)	1,390 (54.7)	1,390 (54.7)	1,505 (59.3)	1,505 (59.3)	1,505 (59.3)
Ground clearance	mm (in)	180 (7.1)	180 (7.1)	180 (7.1)	230 (9.1)	230 (9.1)	230 (9.1)
		190 (7.5)*4	190 (7.5)*4	190 (7.5)*4		240 (9.4)*3	240 (9.4)*3
			240 (9.4)*2	240 (9.4)*2		225 (8.9)*5	225 (8.9)*5

*1: On step bumper equipped models

*2: 4WD appearance models

*3: 255/70R16 tire equipped models

*4: 195R15C tire equipped models

*5: 255/60R17 tire equipped models

*6: Roof rail equipped models