

DATSUN

Model S110 Series

SECTION **ST**

STEERING SYSTEM

CONTENTS

STEERING SYSTEM	ST- 2
STEERING WHEEL AND COLUMN	ST- 3
STEERING WHEEL	ST- 3
STEERING LOCK	ST- 3
STEERING COLUMN (Collapsible type)	ST- 4
STEERING GEAR (Model VRB47L)	ST- 6
STEERING LINKAGE	ST-10

SERVICE DATA AND SPECIFICATIONS	ST-12
GENERAL SPECIFICATIONS	ST-12
INSPECTION AND ADJUSTMENT	ST-12
TIGHTENING TORQUE	ST-12
TROUBLE DIAGNOSES AND CORRECTIONS	ST-13
SPECIAL SERVICE TOOLS	ST-14

ST

Z·ONE·DATSUN

STEERING SYSTEM

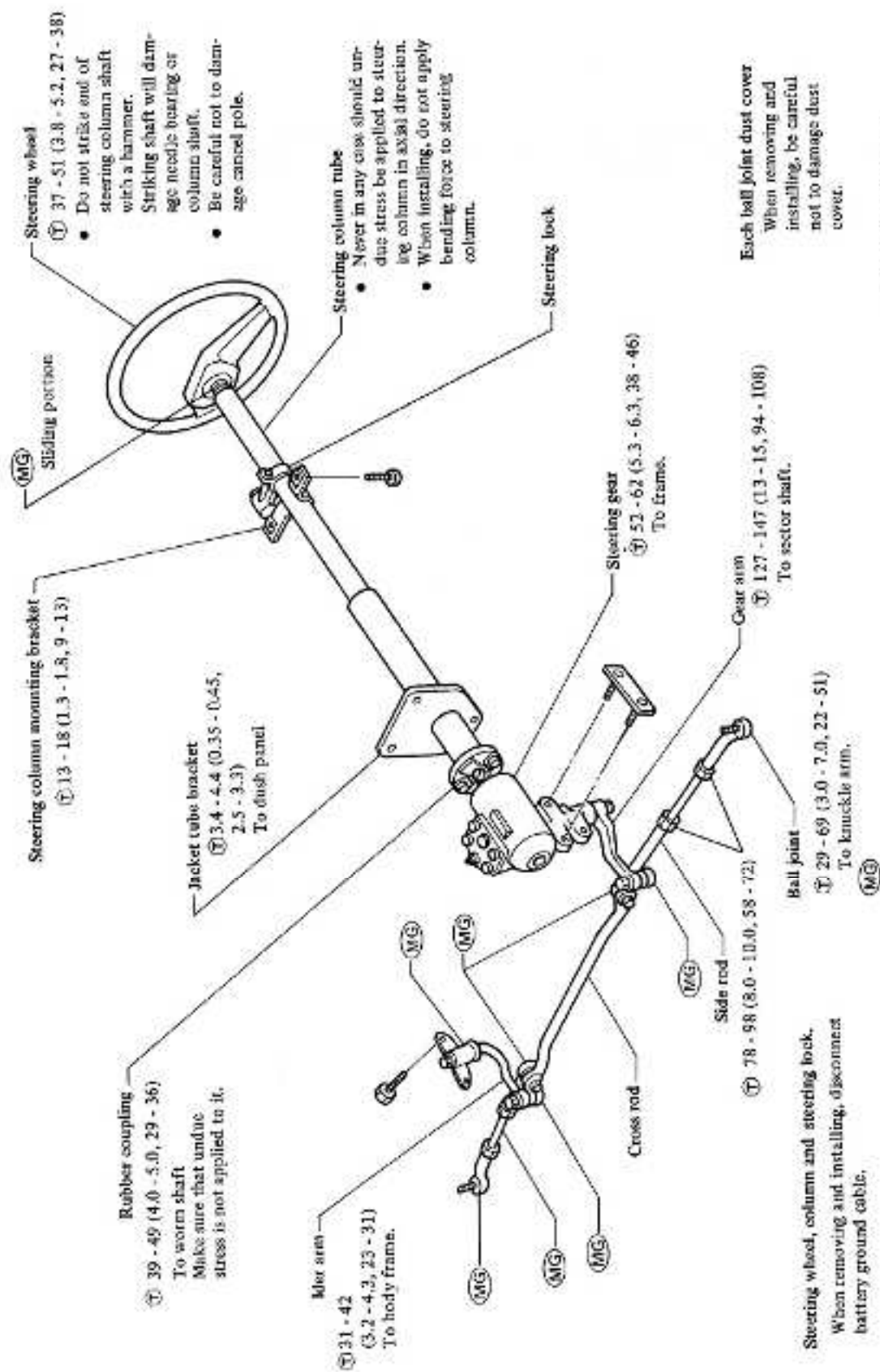

STEERING WHEEL AND COLUMN

STEERING WHEEL

REMOVAL

1. Disconnect battery ground cable.
2. Remove horn pad and steering wheel nut.

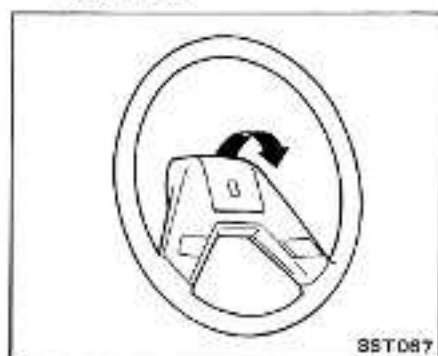

3. Remove steering wheel using Tool.

CAUTION:

Do not strike end of steering column shaft with a hammer. Striking shaft will damage bearing or column shaft.

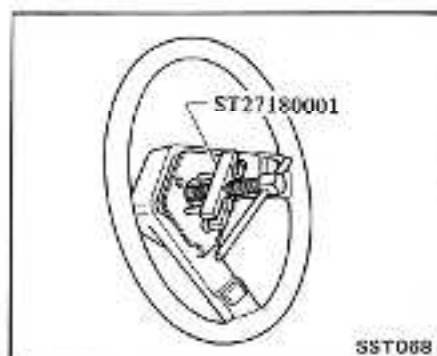

INSTALLATION

Install steering wheel in the reverse order of removal. Observe the following instructions.

1. Apply grease to sliding portions.

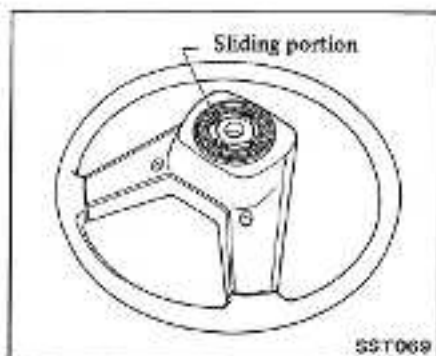

2. Install steering wheel on column shaft in a straight-ahead position.

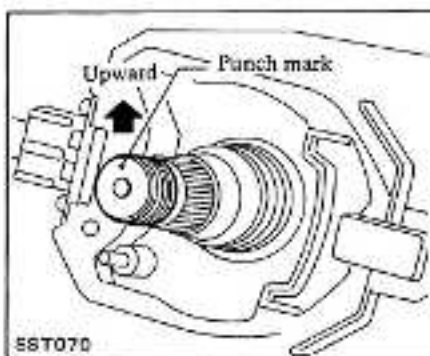

3. Tighten steering wheel nut.

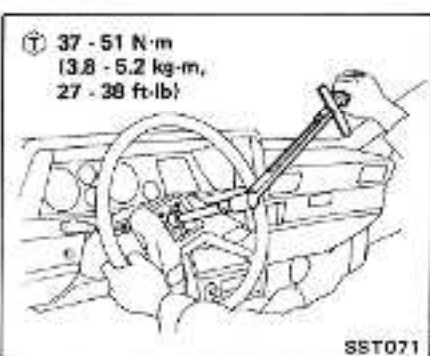

4. After installing steering wheel, turn it clockwise and counterclockwise, checking for catch or drag. Also check horn operation.

STEERING LOCK

REMOVAL

Before removing steering lock, disconnect battery ground cable.

1. Remove steering wheel using Tool ST27180001.
2. Remove steering column shell cover.

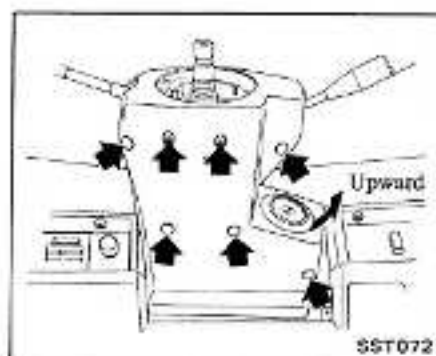

3. Break self-shear type screws with a drill or other appropriate tool.
4. Remove screws and disconnect steering lock.

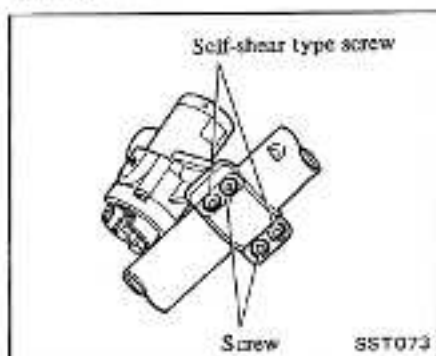

INSTALLATION

1. Align steering lock hole in steering column tube with mating portion of steering lock.
2. Install screws and self-shear type screws and then cut off self-shear type screw heads.

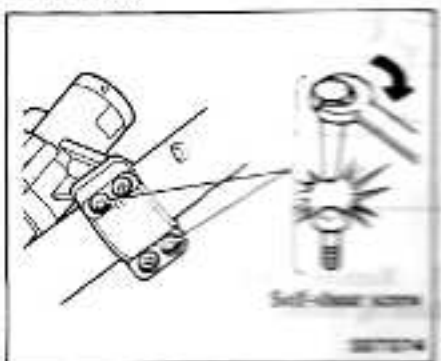

STEERING COLUMN (Collapsible type)

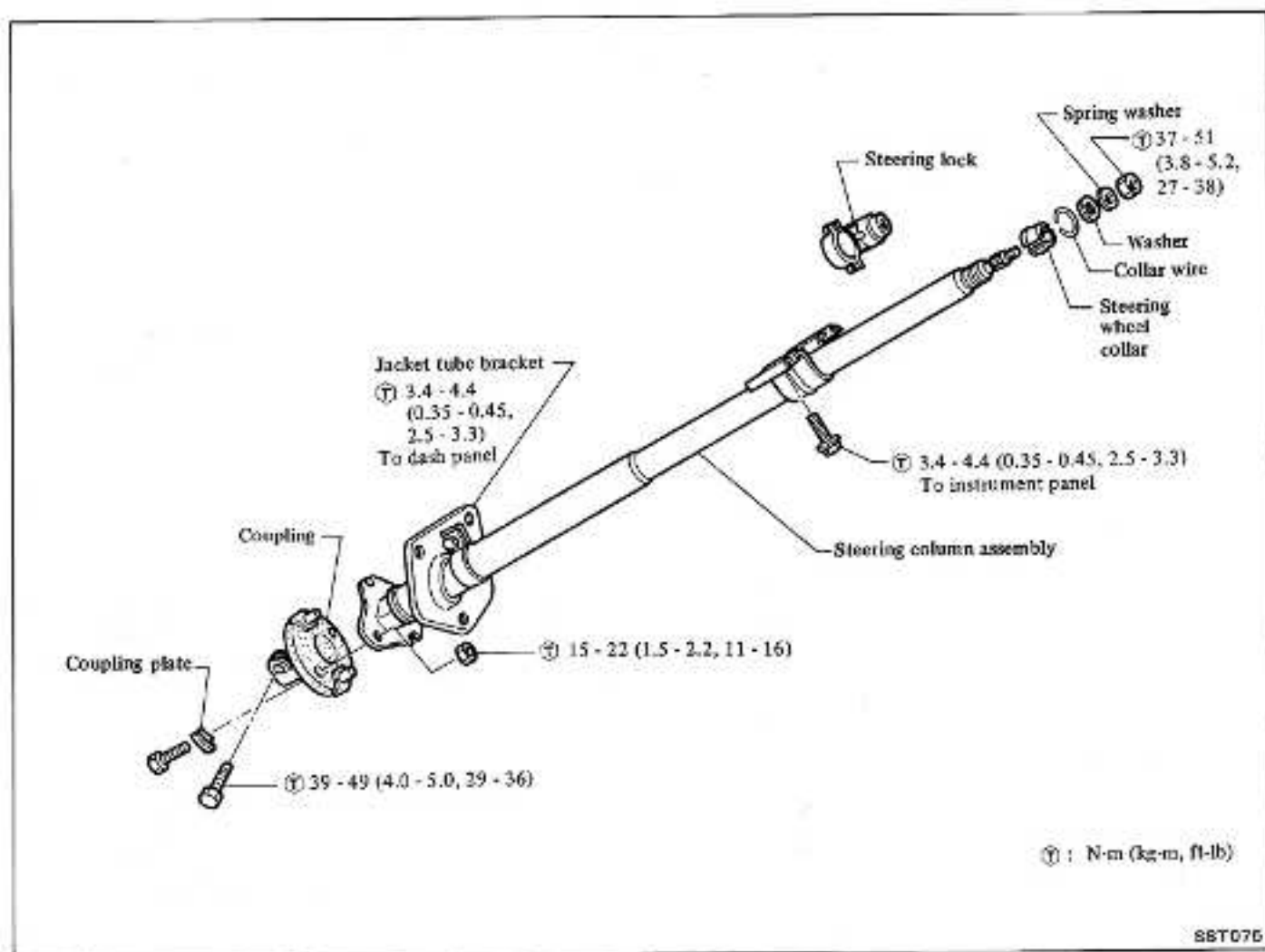

REMOVAL

1. Disconnect battery ground cable.
2. Remove bolt securing worm shaft and rubber coupling.

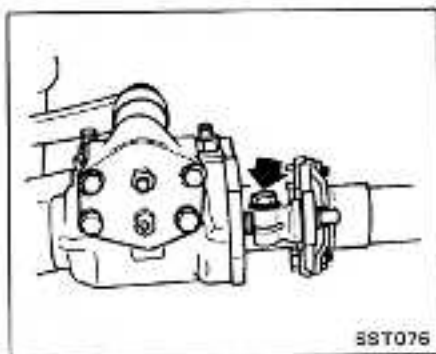

4. Remove steering column shell covers.
5. Remove combination switch assembly.

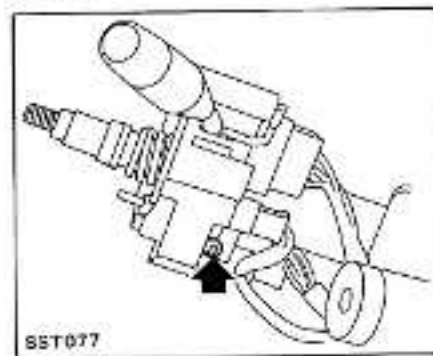

6. Remove heater duct from dash panel side.



3. Remove steering wheel. Refer to Steering Wheel.

7. Remove jacket tube bracket from dash panel.

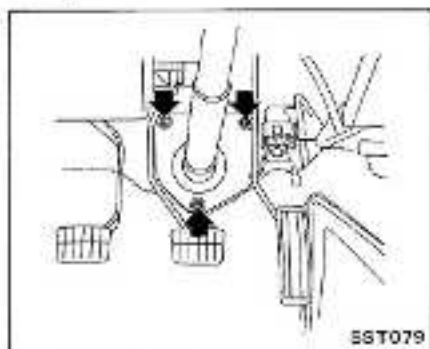

8. Remove column mounting bracket.

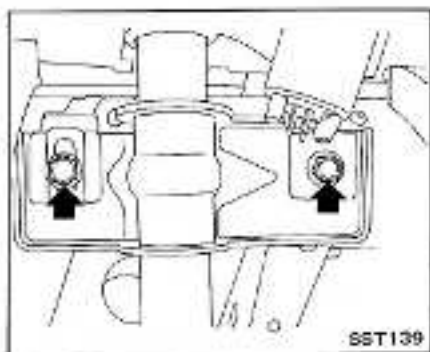

9. Draw out steering column assembly from room side.

INSTALLATION

Install steering column in reverse order of removal.

1. Set wheels in a straight-ahead position.
2. Fit steering column assembly on to worm shaft.

Carefully install so that punch mark at top end of column shaft faces upward.

3. Tighten worm shaft securing bolts temporarily to support upper side of steering column assembly.

4. Tighten column mounting bracket temporarily.

5. After sliding jacket tube bracket to dash panel, tighten nuts to retain it.

⊗ : 3.4 - 4.4 N·m
(0.35 - 0.45 kg·m,
2.5 - 3.3 ft·lb)

6. Tighten worm shaft securing bolts and then tighten column mounting bracket securing bolts.

⊗ : Worm shaft to coupling
39 - 49 N·m
(4.0 - 5.0 kg·m,
29 - 36 ft·lb)
Column mounting bracket
13 - 18 N·m
(1.3 - 1.8 kg·m,
9 - 13 ft·lb)

CAUTION:

- a. Make sure that any undue stress is not applied to rubber coupling.
- b. To avoid damaging bolt or serrations, align groove in worm shaft with bolt hole in rubber coupling.

7. Install steering wheel. Refer to Steering Wheel.

8. After installation, make sure that steering wheel turns smoothly.

INSPECTION

1. When steering wheel can not be rotated smoothly, check the steering column for the following matters and replace faulty parts.

- (1) Check column bearings for damage or unevenness. If so, lubricate with recommended multi-purpose grease or

replace with a new one as steering column assembly.

- (2) Check jacket tube for deformation or breakage, and replace if necessary.

- (3) Check column spring, and replace if damaged or weakened.

2. When the car comes into light collision, check the following parts and replace if necessary.

- (1) Jacket tube

Measure dimension "L".

When jacket tube is crushed, dimension "L" is reduced.

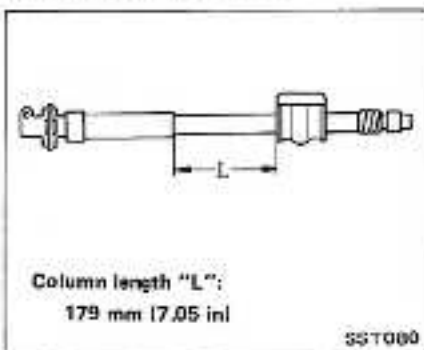

- (2) Column mounting bracket

Make sure column mounting bracket touches block.

Standard "B" dimension is 0 mm (0 in).

When jacket is crushed, dimension B is increased.

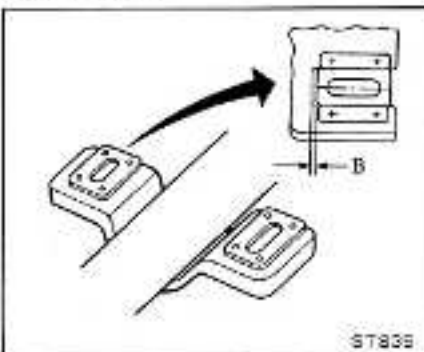

STEERING GEAR (Model VRB47L)

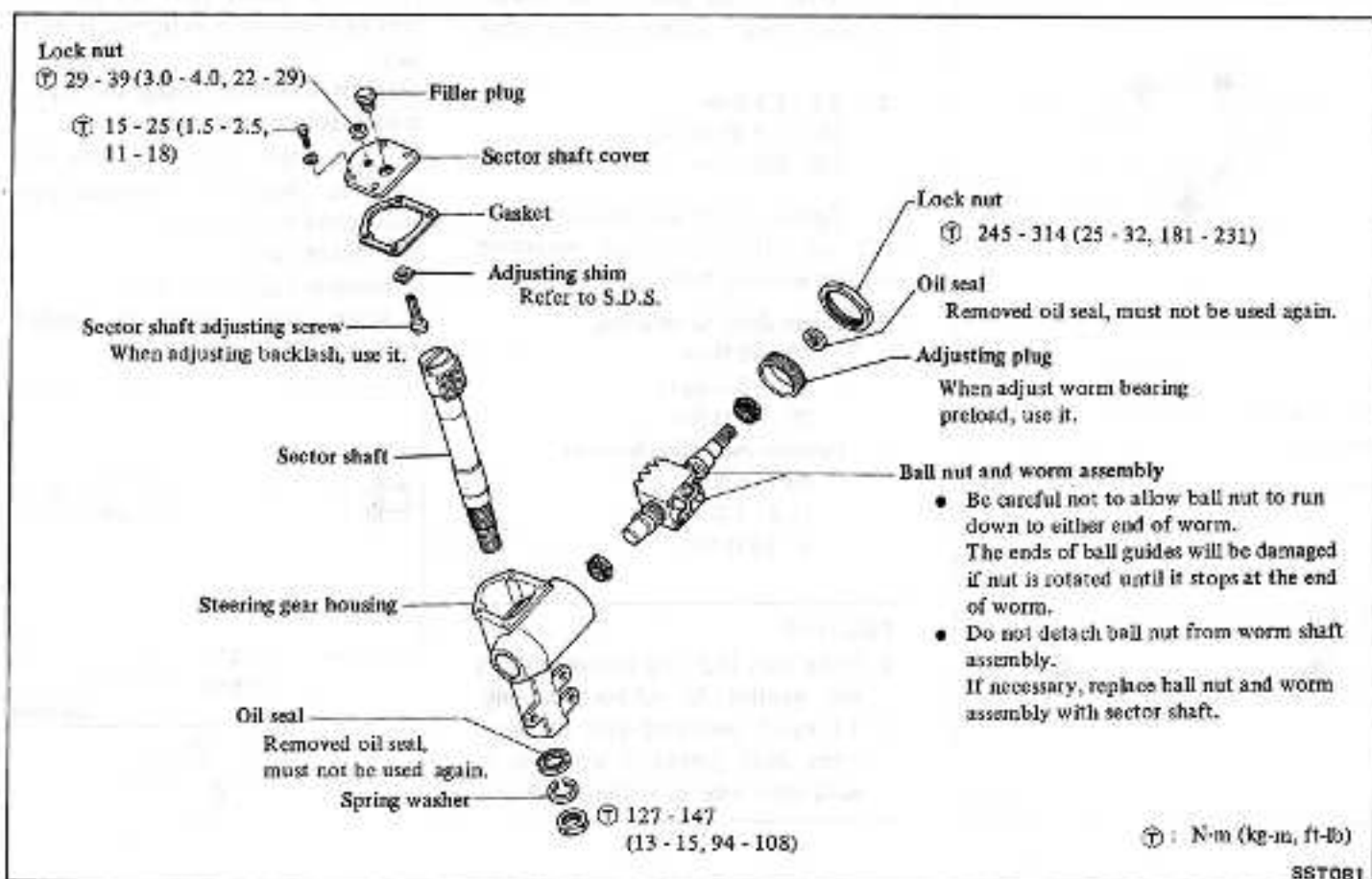

REMOVAL AND INSTALLATION

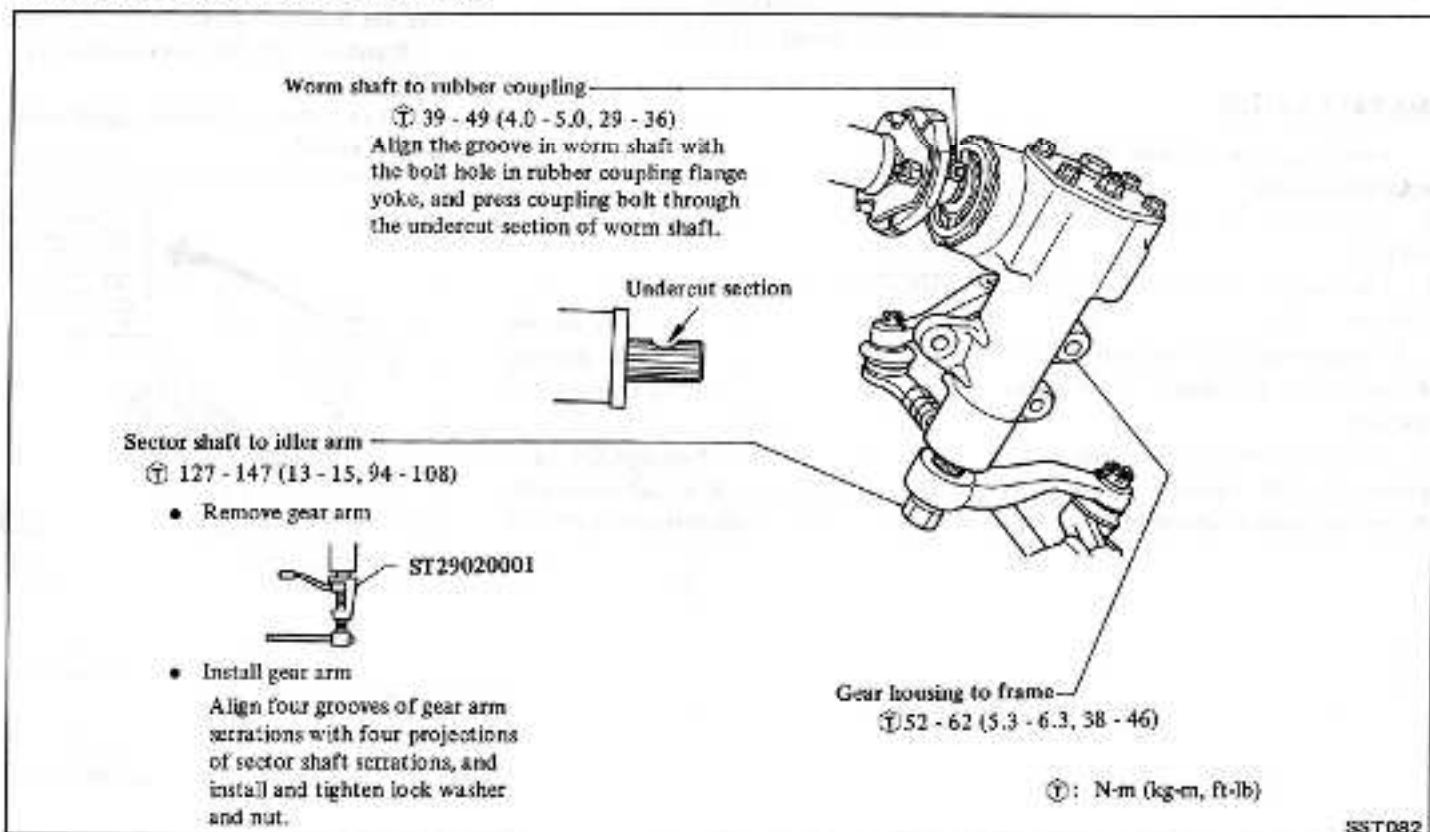

DISASSEMBLY

Before disassembling by hand, make sure external is clean and free from dust and dirt, and thoroughly drain gear fluid by removing filler plug.

1. Place steering gear in a vice using Tool KV48100301 in place.
2. Set worm gear in a straight-ahead position.

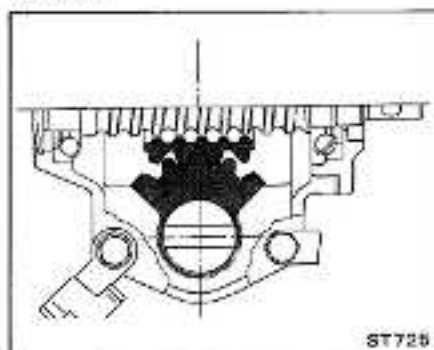

3. Remove sector shaft cover fixing bolts.

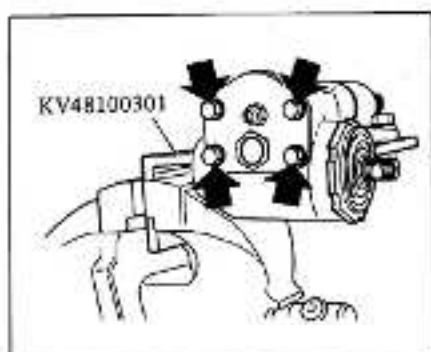

4. Remove sector shaft with sector shaft cover.

CAUTION:

- a. When pulling sector shaft out, be careful not to damage oil seal or associated parts.
- b. Do not remove sector shaft needle bearings from steering gear housing. If necessary, replace gear housing assembly.

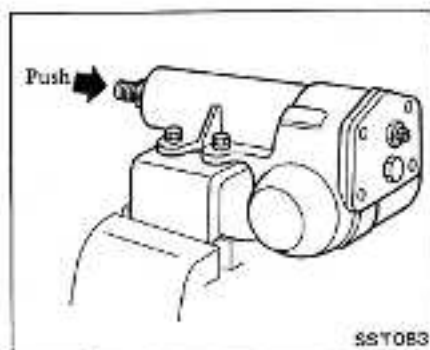

5. Remove sector shaft oil seal, if necessary.

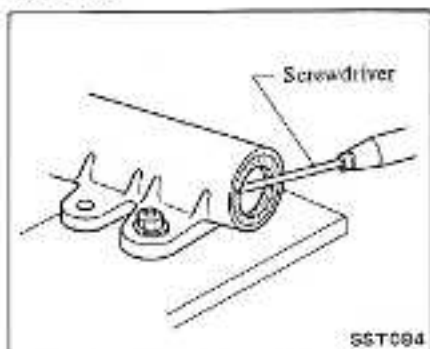

6. Loosen adjusting plug lock nut using Tool.

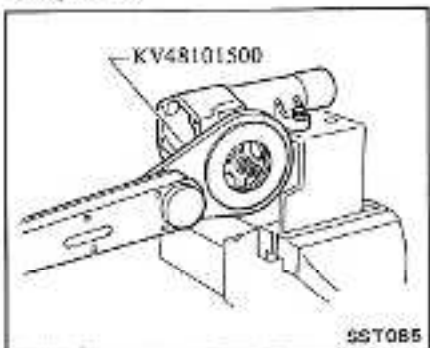

7. Draw out worm gear with worm bearing.

CAUTION:

- a. Be careful not to allow ball nut to run down to either end of worm. Ends of ball guides will be damaged if nut is rotated until it stops at end of worm.
- b. Do not detach ball nut from worm shaft assembly. If necessary, replace entire unit as an assembly.
- c. Do not remove sector shaft needle bearings from steering gear housing. If necessary, replace entire gear housing as an assembly.

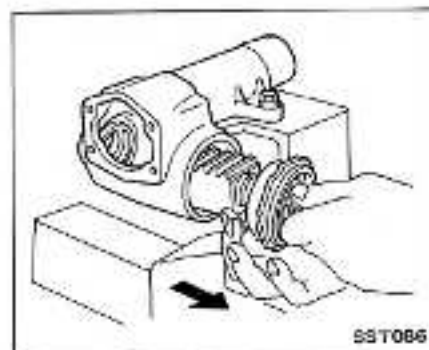

8. Remove oil seal from adjusting plug using Tool.

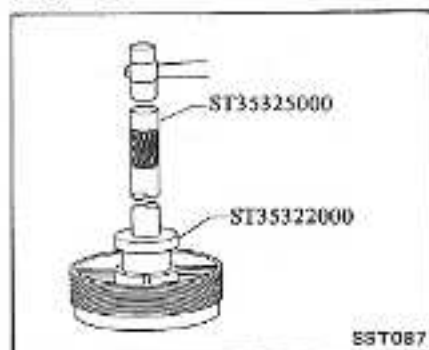

ASSEMBLY AND ADJUSTMENT

- Before assembling and adjusting by hand, make sure each part is clean and lubricate with gear fluid.
- Fill space between sealing lips of new sector shaft and adjusting plug oil seals with recommended multi-purpose grease.

Worm bearing preload

1. Fit worm gear assembly with worm bearing in gear housing.

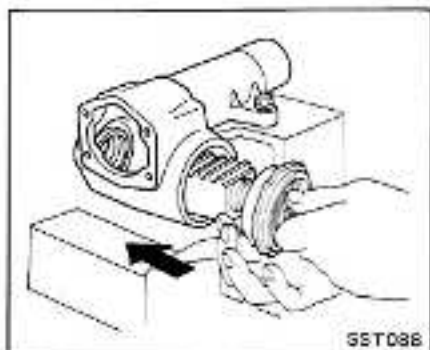

2. Install adjusting plug using Tool KV48101400.
3. Adjust worm bearing preload using Tools.

CAUTION:

Always adjust worm bearing preload by turning adjusting plug in "tighten" direction.

Rotate worm shaft a few turns in both directions to settle down worm bearing and measure preload.

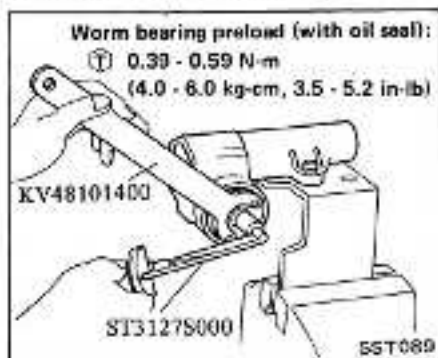

4. Apply suitable liquid sealant around lock nut inner surface.

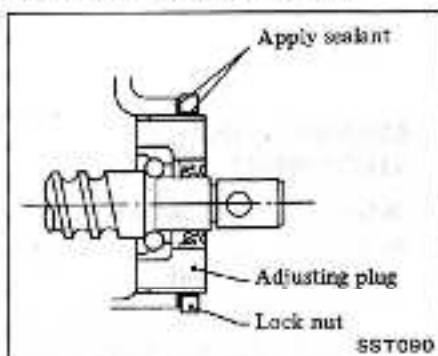

5. Tighten lock nut using Tools.

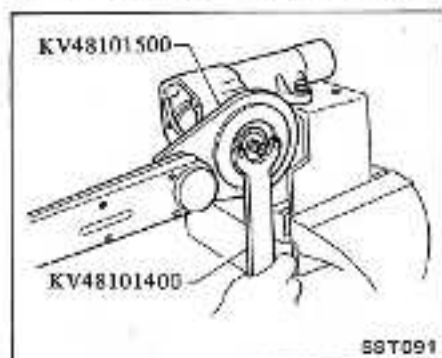

6. After tightening lock nut, check worm bearing preload to make sure it is within specification.

Sector shaft end play

Select suitable adjusting shim and adjust end play between sector shaft and adjusting screw.

Sector shaft adjusting screw shims:
Refer to S.D.S.

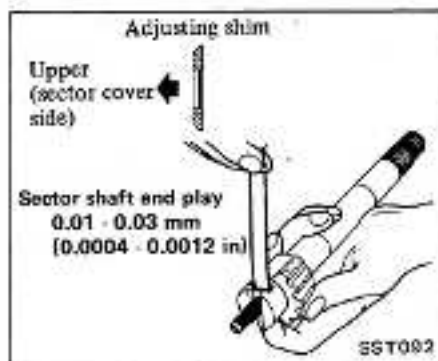

Steering gear preload

1. Press oil seal to steering gear housing using Tool.

Before pressing oil seal, coat seal contacting face of oil seal with gear fluid.

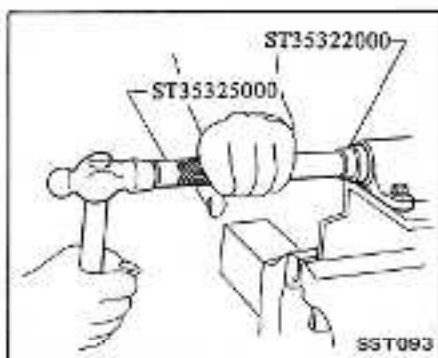

2. Install sector cover on adjusting screw with sector shaft.

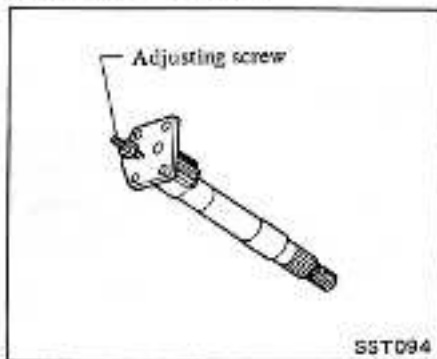

3. Set worm gear in a straight-ahead position.

4. Insert sector shaft and sector cover assembly with gasket into gear housing.

Carefully insert sector shaft in place, using care not to scratch oil seal.

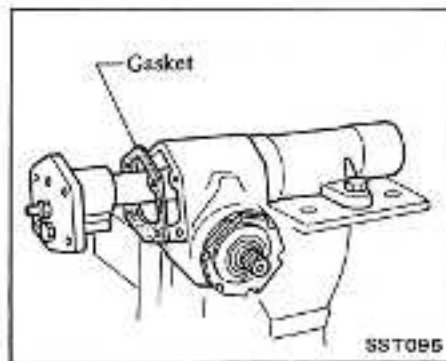

5. Tighten sector cover to gear housing.

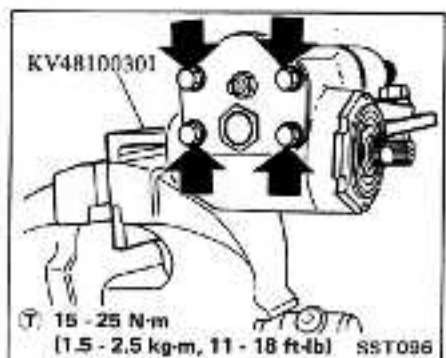

6. Pour recommended gear oil into assembly through filler hole and install filler plug.

Specified refill capacity:
Approximately 0.28 liter
(1/2 Imp pt)

7. Tighten adjusting screw so that gear preload is within specification.

CAUTION:

Always adjust steering gear preload by turning adjusting screw in "tighten" direction.

Rotate worm gear a few turns in both directions to settle down steering gear and then measure steering gear preload.

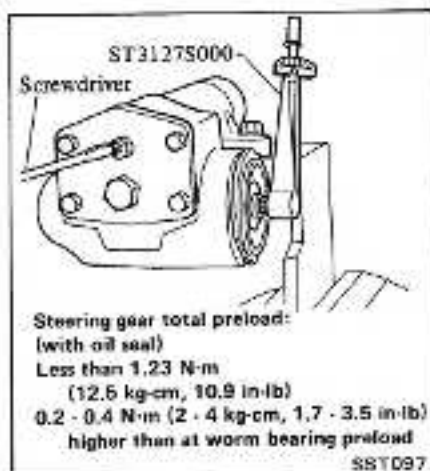

8. If found to be outside of above steering gear preload specifications, readjust adjusting screw until correct steering gear preload is obtained.

INSPECTION

Wash clean all the disassembled parts in solvent and check for condition.

Sector shaft

1. Check gear tooth surface for pitting, burrs, cracks or any other damage, and replace if necessary.
2. Check sector shaft for distortion on its serration, and replace if necessary. Also check gear housing for deformation.

Steering worm assembly

1. Inspect ball nut gear tooth surface, and replace if pitting, burrs, wear or any other damage is found.
2. Ball nut must rotate smoothly on worm gear. If found too tight, assembly should be replaced.

Check rotation of ball nut as follows:

- (1) Move ball nut to either end of worm gear, and gradually stand worm shaft and ball nut assembly until ball nut moves downward on worm gear under its own weight.

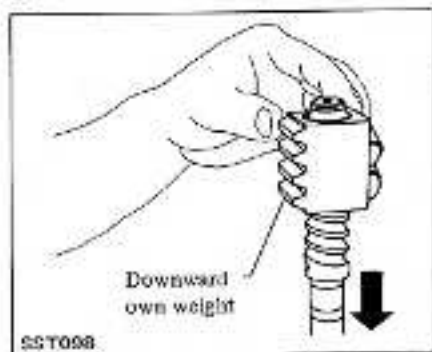

- (2) If ball nut does not move freely over entire stroke, replace assembly.

Be careful not to damage ball nut guide tube while check is being made.

CAUTION:

Be careful not to allow ball nut to run down to either end of worm.

Bearing

1. Inspect worm bearing for wear, pitting or any other damage. Replace as required.

When replacing worm bearing, replace it as a set of bearing and outer race.

2. If sector shaft needle bearings are worn or damaged, replace as an assembly of gear housing and bearings.

Oil seals

Discard any oil seal which has once been removed. Replace oil seal if sealing lip is deformed or cracked. Also discard oil seal if spring is fatigued or dislocated.

STEERING LINKAGE

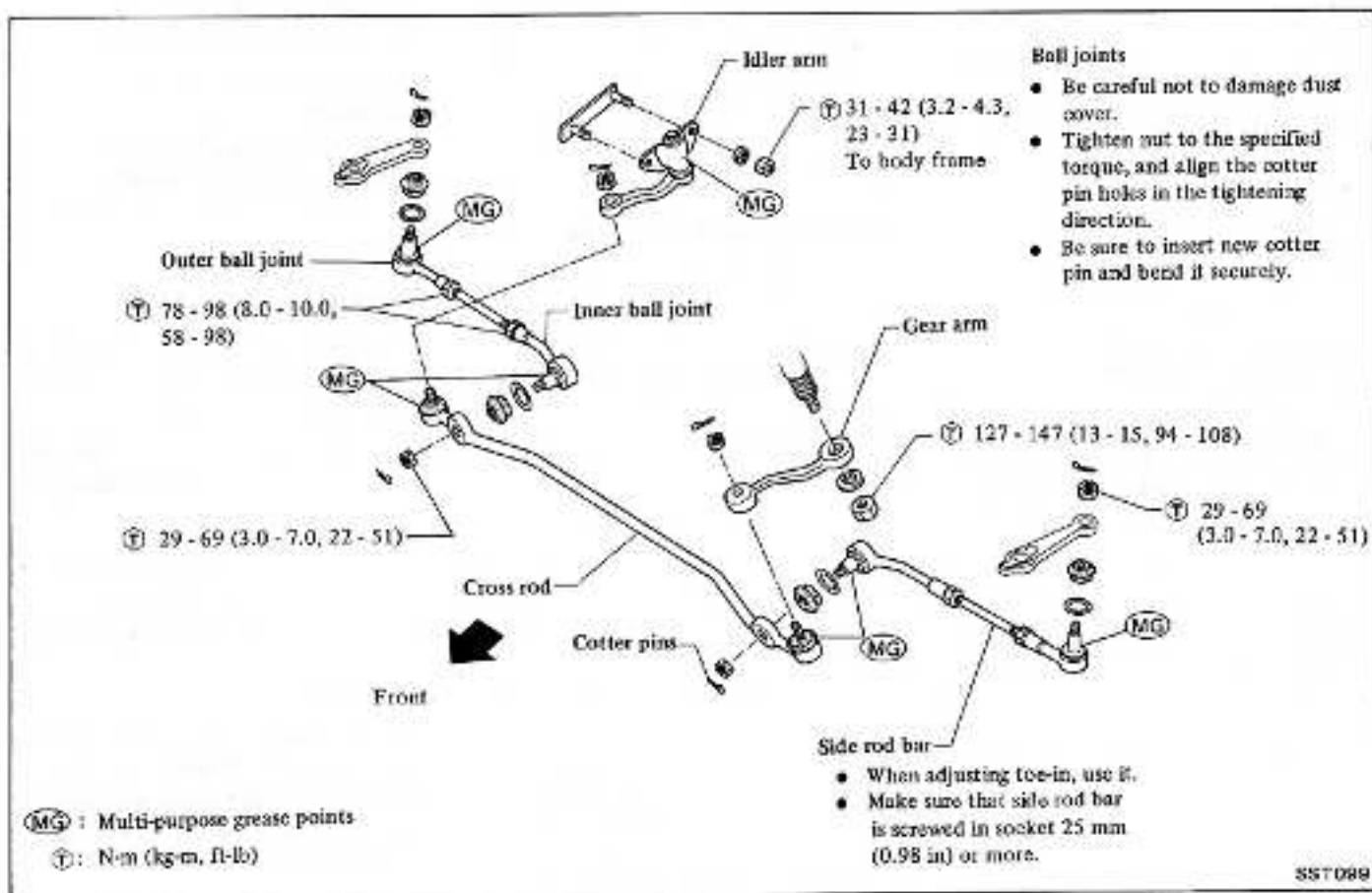

REMOVAL AND INSTALLATION

1. Jack up front of car and support it on the safety stands.
2. Block rear wheels with chocks.
3. Remove gear arm using Tool.

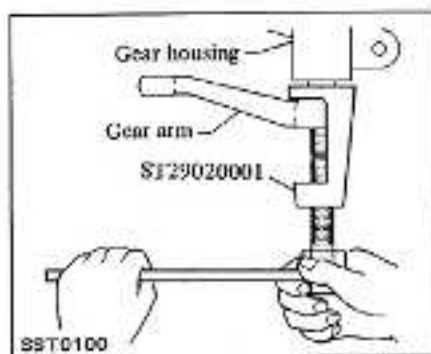

4. Remove idler arm assembly.

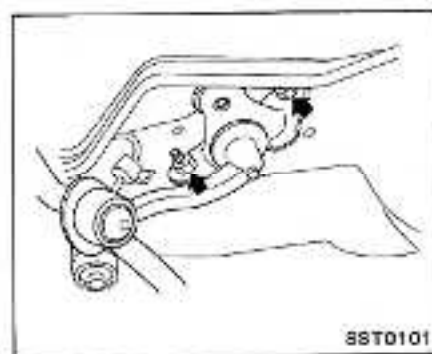

5. Remove side rod from knuckle arm using Tool.

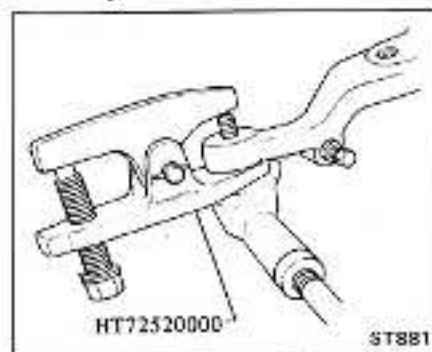

6. Install steering linkage in the reverse order of removal.

- Ⓣ: Gear arm to sector shaft
 127 - 147 N·m
 (13 - 15 kg·m,
 94 - 108 ft·lb)
- Idler arm to body frame
 31 - 42 N·m
 (3.2 - 4.3 kg·m,
 23 - 31 ft·lb)
- Side rod to knuckle arm
 29 - 69 N·m
 (3.0 - 7.0 kg·m,
 22 - 51 ft·lb)

7. After installing steering linkage, check wheel alignment, and if necessary, adjust.

Refer to Section MA for adjustment.

DISASSEMBLY

Side rod

1. Remove both side rods from cross rod using Tool HT72520000.
2. Separate outer and inner ball joints from side rod bar.

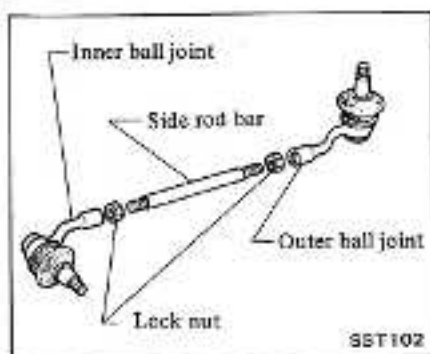

Idler arm assembly

Remove nut, and separate each part.

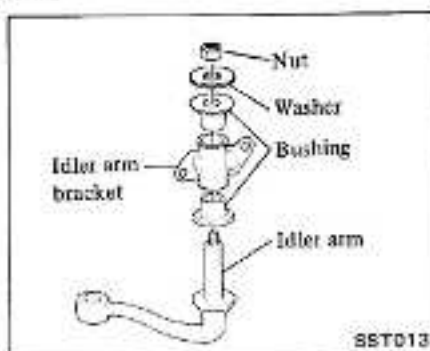

ASSEMBLY

Assemble steering linkage in the reverse order of disassembly, observing the following instructions.

Idler arm assembly

To assemble idler arm, proceed as follows:

1. Apply coat of multi-purpose grease to bushing.

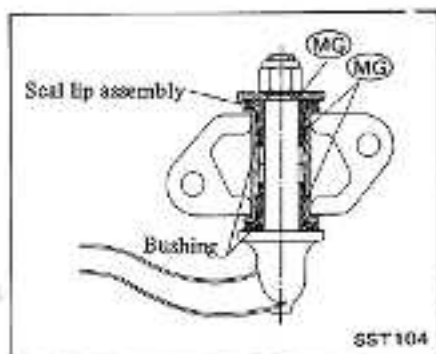

2. Press bushing into idler body, and insert shaft of idler arm bracket carefully until bushing protrudes.

Ⓣ : 54 - 69 N·m
(5.5 - 7.0 kg-m,
40 - 51 ft-lb)

Cross rod and side rod

1. When side rod ball joints and side rod bar are separated, adjust side rod length correctly.

Adjustment should be done between lock nuts.

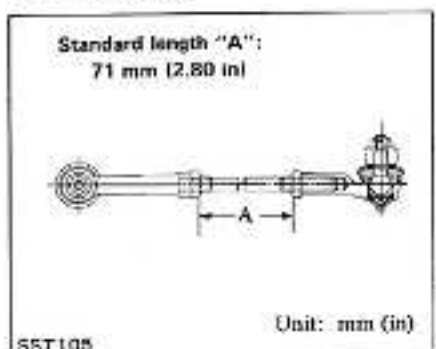

2. Tighten side rod bar lock nut.

Ⓣ : 78 - 98 N·m
(8.0 - 10.0 kg-m,
58 - 72 ft-lb)

- a. Lock side rod bar lock nut so that ball joint on outer socket is 77° with respect to that on inner socket.
- b. Make sure that adjusting bar is screwed in each socket at least 25 mm (0.98 in).

INSPECTION AND REPAIR

Ball joint

1. When ball stud is worn or axial play exists, replace side rod socket with a new one.
2. When dust cover is broken or deformed, be sure to replace with a new one.

Initial turning torque:

Ball joint

0.5 - 2.5 N·m
(5 - 25 kg-cm,
4.3 - 21.7 in-lb)

Swivel pin

Less than
2.5 N·m (25 kg-cm, 22 ft-lb)

Idler arm assembly

Check rubber bushing of idler arm for breakage, wear or play, and if necessary replace.

Apply grease to idler arm assembly at recommended intervals.

Initial turning torque:

Less than
7.8 N·m (80 kg-cm, 69 in-lb)

Cross rod and side rod

Check side rod and cross rod for breakage, bend or crack, and replace with a new one if necessary.

Fixing location

Check fixing location (nuts and cotter pins) for looseness, play or breakage. When looseness or play is found, check for wear on tapered portion of ball stud, gear arm of idler arm.

When reassembling each ball joint, use new cotter pins.

SERVICE DATA AND SPECIFICATIONS

GENERAL SPECIFICATIONS

Steering column	Collapsible column	
Standard column length "L"	mm (in)	179 (7.05)
		
SST080		
Steering gear type	V.R.B. 47L	
Turns of steering wheel on the car (Lock-to-lock)	3.5	
Steering gear ratio	18.0 - 20.5	

STEERING LINKAGE

Ball joint initial turning torque		
Ball joint	N-m (kg-cm, in-lb)	0.49 - 2.45 (5 - 25, 4.3 - 21.7)
Swivel pin	N-m (kg-cm, in-lb)	Less than 2.5 (25, 221)
Idler arm initial turning torque	N-m (kg-cm, in-lb)	Less than 7.8 (80.0, 69)
Standard side rod length	mm (in)	71.0 (2.795)

TIGHTENING TORQUE

STEERING COLUMN

Unit	N-m	kg-m	ft-lb
Steering wheel nut	37 - 51	3.8 - 5.2	27 - 38
Jacket tube bracket to dash panel	3.4 - 4.4	0.35 - 0.45	2.5 - 3.3
Steering column mounting bracket	13 - 18	1.3 - 1.8	9 - 13
Jacket tube bracket clamp	3.4 - 4.4	0.35 - 0.45	2.5 - 3.3
Worm shaft to coupling	39 - 49	4 - 5	29 - 36
Coupling fixing nut	15 - 22	1.5 - 2.2	11 - 16

INSPECTION AND ADJUSTMENT

Front wheel full turning angle		
Inner wheel	degree	33° - 35°
Outer wheel	degree	27° - 29°
Minimum turning radius (Wall to wall)	m (ft)	5.7 (18.7)
Steering wheel axial play	mm (in)	0 (0)
Steering wheel play	mm (in)	Less than 35 (1.38)

STEERING GEAR

Worm bearing preload (With oil seal)	N-m (kg-cm, in-lb)	0.39 - 0.59 (4.0 - 6.0, 3.5 - 5.2)
Steering gear preload (With oil seal)	N-m (kg-cm, in-lb)	Less than 1.23 (12.5, 10.9)
Backlash at gear arm top end (In neutral position)	mm (in)	0 - 0.1 (0 - 0.004)
End play (Between sector shaft and adjusting screw)	mm (in)	0.01 - 0.03 (0.0004 - 0.0012)
Adjusting shim thickness	mm (in)	
	Thickness	Part No.
	1.575 - 1.600 (0.0620 - 0.0630)	48213 B0100
	1.550 - 1.575 (0.0610 - 0.0620)	48214 B0100
	1.525 - 1.550 (0.0600 - 0.0610)	48215 B0100
	1.500 - 1.525 (0.0591 - 0.0600)	48216 B0100
	1.475 - 1.500 (0.0581 - 0.0591)	48217 B0100
	1.450 - 1.475 (0.0571 - 0.0581)	48218 B0100
Oil capacity	liters (imp pt)	About 0.28 (1/2)

STEERING GEAR

Unit	N-m	kg-m	ft-lb
Steering gear housing to body side frame	52 - 62	5.3 - 6.3	38 - 46
Sector shaft to gear arm	127 - 147	13 - 15	94 - 108
Adjusting plug lock nut	245 - 314	25 - 32	181 - 231
Sector shaft cover bolt	15 - 25	1.5 - 2.5	11 - 18
Sector shaft adjusting screw lock nut	29 - 39	3.0 - 4.0	22 - 29

STEERING LINKAGE







Unit	N-m	kg-m	ft-lb
Idler arm to body side frame	31 - 42	3.2 - 4.3	23 - 31
Ball stud nut	29 - 69	3.0 - 7.0	22 - 51
Idler arm nut	54 - 69	5.5 - 7.0	40 - 51
Side rod bar lock nut	78 - 98	8.0 - 10.0	58 - 72

TROUBLE DIAGNOSES AND CORRECTIONS

Except for the following probable causes and corrective actions, refer to Trouble Diagnoses and Corrections in Front Axle and Front Suspension section.

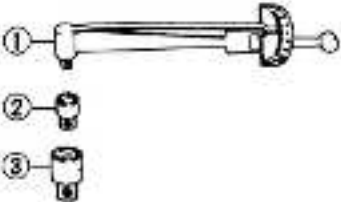
Condition	Probable cause	Corrective action
Excessive wheel play.	Insufficiently tightened or improperly installed steering gear housing. Damaged steering linkage or ball joint. Incorrect adjustment of steering gear.	Retighten. Replace faulty parts. Adjust.
Vibration, shock or shimmying of steering wheel.	Insufficiently tightened or improperly installed steering gear housing. Wear of steering linkage. Damaged idler arm. Worn column bearing, weakened column bearing spring, or loose clamp.	Retighten. Replace faulty parts. Replace. Replace or retighten.
Car pulls to right or left.	Deformed steering linkage and/or suspension link.	Replace.
Stiff or heavy steering wheel.	Insufficient lubricants or mixing impurities in steering linkage or excessively worn steering linkage. Worn or damaged steering gear and bearing. Incorrectly adjusted steering gear. Deformed steering linkage. Interference of steering column with turn signal switch.	Replenish grease or replace the part. Replace. Adjust. Replace. Adjust.

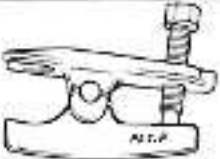
SPECIAL SERVICE TOOLS

Tool number	Tool name	
ST27180001	Steering wheel puller	
KV48100301	Strut & steering gear box attachment	
ST31275000 ① GG91030000 ② HT62940000 ③ HT62900000	Preload gauge Torque wrench Socket adapter Socket adapter	
ST29020001	Steering gear arm puller	
HT72520000	Ball joint remover	
KV48101500	Lock nut wrench	
KV48101400	Adjusting plug wrench	
① ST35322000 ② ST35325000	Front wheel bearing drift Drift bar	